



Opportunity

# 2017 Opportunity

臺灣國際學生創意設計大賽  
Taiwan International Student Design Competition

---



# Opportunity

Taiwan International Student Design Competition

2017



## 前言

### 一、計畫緣起

教育部自 2003 年起以學校現有資源為基礎，整備大學校院藝術及設計相關系所人才養成環境，除推動「大學校院藝術與設計系所人才培育計畫」外，更自 2005 年起開始辦理「藝術與設計菁英海外培訓計畫」及「鼓勵學生參加藝術與設計類國際競賽」。

2010 年開始舉辦的「臺灣國際學生創意設計大賽」為教育部 2008 年開始推動的「臺灣國際創意設計大賽」－「學生組競賽」延伸而來，結合教育部現有藝術與設計人才培育計畫的競爭優勢，藉由臺灣自主性地舉辦國際級的學生設計競賽，除了用以鼓勵全球藝術與設計院校學生參與競賽之外，更可透過設計競賽活動的舉辦期間，充分善用媒體與文宣推廣臺灣。藉由國際專家學者來臺擔任評審，或是榮獲獎項的國外學生來臺領獎，進而認識臺灣與推廣臺灣設計教育的成果。

### 二、活動目的

教育部為激發全球學生創意設計能量，鼓勵國際間學生創意設計交流，發掘新生代創意人才，展現臺灣重視創意設計之國際形象，建立臺灣之國際設計地位，並強化臺灣設計人才與國際接軌，特舉辦此競賽。

### 三、本屆競賽概述

由教育部青年發展署主辦、亞洲大學視覺傳達設計學系承辦的「2017 臺灣國際學生創意設計大賽」，已邁入第十個年頭，為全球最具指標性的大型學生設計競賽之一。今年競賽以「Opportunity」為主題，期望學生面對挑戰、選擇機會、整合資源、創造價值，終透過設計體現，傳達 Opportunity 的概念。本屆共有四個類別「產品設計類」、「視覺設計類」、「數位動畫類」及「廠商指定類」，向世界各地的學生徵件，吸引來自 71 個國家、910 所學校的同學報名參加，徵得超過 18,000 多件作品共襄盛舉，初選分別選出：產品設計類 109 件、視覺設計類 226 件、數位動畫類 39 件、廠商指定類 49 件，共 423 件優秀作品進入決選。並於 10 月 6 日由 27 位國內外專家學者和設計界菁英，最終選出年度大獎一名、國際設計組織特別獎、各類組金、銀、銅獎、佳作得主，總計頒發 68 個獎項，發出近新臺幣 480 萬元的高額獎金。



## 四、競賽辦法

### 線上報名及參賽作品送件截止

2017年6月1日至2017年7月25日，  
臺北時間 24:00 (GMT+08:00)

初選	2017年9月2 - 4日
入圍名單公告並通知第二階段交件	2017年9月12日
決選	2017年10月6日
頒獎典禮	2017年11月27日
獲獎作品展覽	2017年11月29日 - 12月08日

### 參賽資格

限定國內外高級中等以上學校在校學生（以網路截止報名時間為準，須為西元1987年5月29日之後出生，年齡30歲以內。女性申請人於申請年限之前曾有生育事實者，每胎得延長年限兩年）

※ 應屆畢業生（2017年6月畢業）及新生（2017年9月入學）皆可報名參加。

### 參賽類別

產品設計類、視覺設計類、數位動畫類、廠商指定類，共四類

### 報名費用

免繳報名費

### 頒發獎項

產品設計、視覺設計與數位動畫類

年度大獎（1名）：

獎金新臺幣四十萬元，獎盃一座，獎狀一紙

金獎（產品、視覺、動畫各1名）：

獎金新臺幣二十五萬元，獎盃一座，獎狀一紙

銀獎（產品、視覺、動畫各1名）：

獎金新臺幣十五萬元，獎盃一座，獎狀一紙

銅獎（產品、視覺、動畫各3名）：

獎金新臺幣六萬元，獎盃一座，獎狀一紙

佳作（若干名）：

獎金新臺幣一萬元，獎狀一紙

國際設計組織特別獎（16名）：

獎金新臺幣十萬元，獎盃一座，獎狀一紙

### 廠商指定類

看見台灣基金會「新食器時代－臺灣茶具設計」

金獎（1名）：獎金新臺幣二十五萬元，獎盃一座，獎狀一紙

銀獎（2名）：獎金新臺幣十五萬元，獎盃一座，獎狀一紙

銅獎（4名）：獎金新臺幣六萬元，獎盃一座，獎狀一紙

佳作（若干名）：獎金新臺幣一萬元，獎狀一紙



參賽國家：12  
網路報名人數：1126人  
實際收件數量：662件  
臺灣：559件 (84%)  
海外：103件 (16%)  
學校數：83所



參賽國家：19  
網路報名人數：4923人  
實際收件數量：2459件  
臺灣：2038件 (82%)  
海外：421件 (18%)  
學校數：130所



參賽國家：24  
網路報名人數：6492人  
實際收件數量：3498件  
臺灣：2545件 (73%)  
海外：953件 (27%)  
學校數：249所



參賽國家：31  
網路報名人數：3766人  
實際收件數量：3954件  
臺灣：2815件 (71%)  
海外：1139件 (29%)  
學校數：369所



參賽國家：35  
實際收件數量：3421件  
臺灣：2315件 (68%)  
海外：1106件 (32%)  
學校數：516所



參賽國家：37  
實際收件數量：3890件  
臺灣：2179件 (56%)  
海外：1711件 (44%)  
學校數：553所



參賽國家：43  
實際收件數量：4073件  
臺灣：1930件 (47%)  
海外：2143件 (53%)  
學校數：721所



參賽國家：46  
實際收件數量：7985件  
臺灣：3360件 (42%)  
海外：4625件 (58%)  
學校數：790所

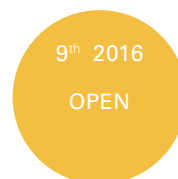

參賽國家：69  
實際收件數量：14864件  
臺灣：5726件 (39%)  
海外：9138件 (61%)  
學校數：882所



參賽國家：71  
實際收件數量：18932件  
臺灣：6966件 (37%)  
海外：11966件 (63%)  
學校數：910所

## Foreword

### I. Plan History

Since 2003, the MOE has been utilizing its existing educational and school resources for the nurturing of talented young people, especially in the areas of art and design. Through the promotion of the "MOE's Program in Human Resource Development for Colleges of Art and Design", the "MOE Scholarship Programs for Overseas Study in Art and Design" and the "MOE Award Incentive Program for Encouraging University/College Students to participate in International Art and Design Contests", talented individuals have been given valuable opportunities to further develop their areas of exceptional interests and creativity. From 2010, the "Taiwan International Student Design Competition" is held after the "Taiwan international Design Competition—the Student Section" in 2008 & 2009. It integrates the competitive edges of MOE art and design talent fostering programs. By hosting international student design competitions, "Taiwan International Design Competition—the Student Section", additionally encourages art and design students worldwide to participate in contests, which can utilize media and advertisements to promote Taiwan; the program allows international judges or panelists and award winners to advertise the successes of Taiwan's art and design education programs.

### II. Objectives of the Plan

Encourage international creative design exchange, develop creative design talents, express the international image of Taiwan attaching great importance to creative design, and establish the international design status of Taiwan.

### III. About 2017 TISDC

Organized by the Youth Development Administration of the Ministry of Education and executed by the Department of Visual Communication Design, Asia University. 2017 Taiwan International Student Design Competition is now in its 10th year and has become one of the largest student design competitions in the world. The theme of this year's competition is "Opportunity." We encourage participants to take on challenges, embrace opportunities, harmonize resources and create value. Through unique design and implementation in light to best convey the concept of Opportunity. This year, besides the original Product Design, Visual Design, Digital Animation, and Brand Specified categories. This year's competition has attracted more than 18,000 entries and registers from 910 schools and departments in 71 countries. After rounds of intense discussion in the Preliminary Selection, 109 pieces in Product Design, 226 pieces in the Visual Design Category, 39 pieces in Digital Animation, and 49 pieces in Brand Specified, total 423 pieces of nominated work were chosen to enter the Final Selection. On October 6, 27 design experts from Taiwan and abroad grouped as jury and finally decided the winners of Grand Prix, International Design Association Special Prizes, Gold, Silver, Bronze and Honorable Mention prizes, numbering a total of 68 pieces of winning work. It is estimated that near 4.8 million NTD dollars of prize money will be handed out.





## IV. Procedure

Online Registration and Online Work Submission

June 1, 2017 to July 25, 2017, 24:00 (Taipei GMT+08:00)

Preliminary Selection	September 2 - 4, 2017
Finalists Announcement	September 12, 2017
Final Selection	October 6, 2017
Award Ceremony	November 27, 2017
Exhibition	November 29 - December 8, 2017

### Qualification

Students who currently enroll at senior high schools or above (Based on the internet registration deadline, and the participant must be born after May 29, 1987, and be younger than 30 years of age. For females who have given birth before year of 30 may have 2 years extension per birth.).

\*Fresh graduates (graduate in June 2017) and new students (enroll school in September, 2017) are also eligible.

### Category

Product Design, Visual Design, Digital Animation, and Brand Specified

### Registration Fee

Free

## Awards

Product Design, Visual Design, and Digital Animation Categories

### Grand Prix (1 winner) :

NT\$400,000 (approx. US\$13,000), an awarding cup and a certificate

### Gold Prize (1 winner for each category) :

NT\$250,000 (approx. US\$8,000), an awarding cup and a certificate

### Silver Prize (1 winner for each category) :

NT\$150,000 (approx. US\$5,000), an awarding cup and a certificate

### Bronze Prize (3 winners for each category) :

NT\$60,000 (approx. US\$2,000), an awarding cup and a certificate

### Honorable Mention Prize (several winners for each category) :

NT\$10,000 (approx. US\$330) and a certificate

### International Design Association Special Prize (16 winners):

NT\$100,000 (approx. US\$3,300), an awarding cup and a certificate

### Brand Specified Category

iSee Taiwan Foundation Innovative Design Awards - Taiwan Teaware Design

### Gold Prize (1 winner for each category):

NT\$250,000 (approx. US\$8,000), an awarding cup and a certificate

### Silver Prize (2 winner for each category):

NT\$150,000 (approx. US\$5,000), an awarding cup and a certificate

### Bronze Prize (4 winners for each category):

NT\$60,000 (approx. US\$2,000), an awarding cup and a certificate

### Honorable Mention Prize (several winners for each category):

NT\$10,000 (approx. US\$330) and a certificate



Participating Countries/Regions: 12  
Number of Online Registration: 1126  
Number of Project Received: 662  
Taiwan: 559 (84%)  
Overseas: 103 (16%)  
Number of Schools: 83



Participating Countries/Regions: 19  
Number of Online Registration: 4923  
Number of Project Received: 2459  
Taiwan: 2038 (82%)  
Overseas: 421 (18%)  
Number of Schools: 130



Participating Countries/Regions: 24  
Number of Online Registration: 6492  
Number of Project Received: 3498  
Taiwan: 2545 (73%)  
Overseas: 953 (27%)  
Number of Schools: 249

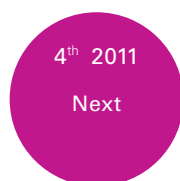

Participating Countries/Regions: 31  
Number of Online Registration: 3766  
Number of Project Received: 3954  
Taiwan: 2815 (71%)  
Overseas: 1139 (29%)  
Number of Schools: 369



Participating Countries/Regions: 35  
Number of Online Registration: 3421  
Taiwan: 2315 (68%)  
Overseas: 1106 (32%)  
Number of Schools: 516



Participating Countries/Regions: 37  
Number of Online Registration: 3890  
Taiwan: 2179 (56%)  
Overseas: 1711 (44%)  
Number of Schools: 553



Participating Countries/Regions: 43  
Number of Online Registration: 4073  
Taiwan: 1930 (47%)  
Overseas: 2143 (53%)  
Number of Schools: 721



Participating Countries/Regions: 46  
Number of Online Registration: 7985  
Taiwan: 3360 (42%)  
Overseas: 4625 (58%)  
Number of Schools: 790



Participating Countries/Regions: 69  
Number of Online Registration: 14864  
Taiwan: 5726 (39%)  
Overseas: 9138 (61%)  
Number of Schools: 882



Participating Countries/Regions: 71  
Number of Online Registration: 18932  
Taiwan: 6966 (37%)  
Overseas: 11966 (63%)  
Number of Schools: 910

- 16 教育部潘文忠部長  
Wen-Chung Pan, Minister, Ministry of Education
- 
- 18 2017 臺灣國際學生創意設計大賽計畫主持人林磐聿  
Apex Lin, Pang-Soong, Project Director, 2017 Taiwan International Student Design Competition

年度大獎 Grand Prix

	作者姓名 Name of Designer(s)	作品名稱 Title of Work	學校所在地 Location of School	學校名稱 Name of School
24	Hyunsu Park、Hyungjun Koo、 Jaeyon Kim、Seonggon Jin、 Minseop Woo、Hanna Lee、 Chanmi Kim、Wansik Jang	Water Mask Dispenser	韓國 Korea	國民大學 Kookmin University

38 法國設計師聯盟特別獎 AFD Special Award

作者姓名 Name of Designer(s)	作品名稱 Title of Work	學校所在地 Location of School	學校名稱 Name of School
王尹伶 Yin-Ling Wang	Pick and Throw	臺灣 Taiwan	國立臺灣師範大學 National Taiwan Normal University

39 捷克布魯諾雙年展協會特別獎 SBB Special Award

作者姓名 Name of Designer(s)	作品名稱 Title of Work	學校所在地 Location of School	學校名稱 Name of School
Anna Dmitrieva	Book about Eyes	俄羅斯 Russia	國立高等經濟大學 - 藝術與設計學院 HSE Art and Design School

40 新加坡設計業總商會特別獎 DBCS Green Design Award

作者姓名 Name of Designer(s)	作品名稱 Title of Work	學校所在地 Location of School	學校名稱 Name of School
Farhana Hossain	The Dumb Elephant	美國 United States of America	紐約視覺藝術學院 School of Visual Arts

41 澳大利亞優秀設計協會特別獎 GDA Design Innovation Award

作者姓名 Name of Designer(s)	作品名稱 Title of Work	學校所在地 Location of School	學校名稱 Name of School
林瑋群、章芸甄 Wei-Chun Lin, Yun-Jen Jang	小事 RUKI	臺灣 Taiwan	東海大學 Tunghai University

42 德國國家設計委員會特別獎 GDC Special Award

作者姓名 Name of Designer(s)	作品名稱 Title of Work	學校所在地 Location of School	學校名稱 Name of School
Aleksandra Zeromska	Wooden Crutches	瑞士 Switzerland	洛桑藝術學院 Ecole cantonale d'art de Lausanne (ECAL)

43 香港設計總會特別獎 FHKDA Special Award

作者姓名 Name of Designer(s)	作品名稱 Title of Work	學校所在地 Location of School	學校名稱 Name of School
Ninaad Kulkarni	KCLOC	美國 United States of America	紐約視覺藝術學院 School of Visual Arts

44 國際設計社團協會特別獎 ico-D Excellence Award

作者姓名 Name of Designer(s)	作品名稱 Title of Work	學校所在地 Location of School	學校名稱 Name of School
Ching-Tien Chu	Verge	美國 United States of America	紐約視覺藝術學院 School of Visual Arts

45 印度設計委員會特別獎 IDC Special Award

作者姓名 Name of Designer(s)	作品名稱 Title of Work	學校所在地 Location of School	學校名稱 Name of School
何靜 Jing He	彈珠輸液袋 Marble Infusion Bag	中國大陸 China	天津理工大學 Tianjin University of Technology

## 46 墨西哥國際海報雙年展協會特別獎 IPBM Special Award

作者姓名 Name of Designer(s)	作品名稱 Title of Work	學校所在地 Location of School	學校名稱 Name of School
黃天韻、王穎婷、黃心如、 曾子容、張巧妍、羅詩雅 Tien-Yun Huang, Ying-Ting Wang, Hsin-Ju Huang, Zih-Rong Zeng, Chiao-Yen Chang, Shi-Ya Luo	米好！Malahok Millet Malahok	臺灣 Taiwan	國立臺中科技大學 National Taichung University of Science and Technology

## 47 日本設計振興會特別獎 JDP Special Award

作者姓名 Name of Designer(s)	作品名稱 Title of Work	學校所在地 Location of School	學校名稱 Name of School
Asish Mohandas	Maattam-Retrofit Patient Transfer System	印度 India	印度理工學院 (坎普爾) Indian Institute of Technology, Kanpur

## 48 韓國現代設計協會特別獎 KECD Special Award

作者姓名 Name of Designer(s)	作品名稱 Title of Work	學校所在地 Location of School	學校名稱 Name of School
爐宏文 Hong-Wun Lu	是開放還是限制？ OPEN or RESTRICT?	臺灣 Taiwan	國立雲林科技大學 National Yunlin University of Science and Technology

## 49 澳門設計師協會特別獎 MDA Special Award

作者姓名 Name of Designer(s)	作品名稱 Title of Work	學校所在地 Location of School	學校名稱 Name of School
許雅媛、王意姍、林郁儒、 李怡軒、黃筱涵 Ya-Yuan Hsu, Yi-Shan Wang, Yu-Ru Lin, Yi-Hsuan Lee, Xiao-Han Huang	Retouch	臺灣 Taiwan	朝陽科技大學 Chaoyang University of Technology

## 50 泰國創意設計中心特別獎 TCDC Special Award

作者姓名 Name of Designer(s)	作品名稱 Title of Work	學校所在地 Location of School	學校名稱 Name of School
康超 Chao Kang	燈塔 The Lighthouse	中國大陸 China	福州大學廈門工藝美術學院 Xiamen Academy of Arts and Design, Fuzhou University

## 51 亞洲設計連特別獎 tDA Asia Special Award

作者姓名 Name of Designer(s)	作品名稱 Title of Work	學校所在地 Location of School	學校名稱 Name of School
邱士杰、張明潔、林孝親、 林思妤 Shih-Chieh Chiu, Ming-Chieh Chang, Hsiao-Chin Lin, Szu-Yu Lin	基石 Fundamental	臺灣 Taiwan	國立臺灣藝術大學 National Taiwan University of Arts

## 52 台灣創意設計中心最具商品化潛力獎 TDC Greatest Market Potential Award

作者姓名 Name of Designer(s)	作品名稱 Title of Work	學校所在地 Location of School	學校名稱 Name of School
Jexter Lim Sen Ye	Eatsy	新加坡 Singapore	新加坡國立大學 National University of Singapore

## 53 紐西蘭設計師協會特別獎 DINZ Best Design Special Award

作者姓名 Name of Designer(s)	作品名稱 Title of Work	學校所在地 Location of School	學校名稱 Name of School
趙丹婷、張丹妮 Dan-Ting Zhao, Dan-Ni Zhang	孤獨症 Autism	中國大陸 China	中國美術學院 China Academy of Art

56 Gold Prize 金獎

作者姓名 Name of Designer(s)	作品名稱 Title of Work	學校所在地 Location of School	學校名稱 Name of School
Chiam Yong Sheng Kevin	Folks Kitchenware for the Blind	新加坡 Singapore	新加坡國立大學 National University of Singapore

58 Silver Prize 銀獎

作者姓名 Name of Designer(s)	作品名稱 Title of Work	學校所在地 Location of School	學校名稱 Name of School
徐文鑫、王子健、歐陽雪欣 Wen-Xin Xu, Zi-Jian Wang, Xue-Xin Ouyang	門門鎖 DoorBolt	中國大陸 China	武漢理工大學 Wuhan University of Technology

59 Bronze Prize 銅獎

作者姓名 Name of Designer(s)	作品名稱 Title of Work	學校所在地 Location of School	學校名稱 Name of School
陳子捷、袁千涵 Zih-Jie Chen, Chien-Han Yuan	線 - 跨越 Across Line	臺灣 Taiwan	國立臺灣科技大學 National Taiwan University of Science and Technology
陳彥廷、陳彥廷、陳冠廷 Yen-Tin Chen, Yen-Ting Chen, Guan-Tin Chen	漂浮護欄 Float Barrier	臺灣 Taiwan	國立臺北科技大學 National Taipei University of Technology
Janis Beinerts, Susanne Duswald	Aero	瑞典 Sweden	優密歐大學 Umeå University

62 佳作 Honorable Mention Prize

作者姓名 Name of Designer(s)	作品名稱 Title of Work	學校所在地 Location of School	學校名稱 Name of School
梁哲誠 Che-Cheng Liang	城市養蜂計畫 Beekeeper	臺灣 Taiwan	實踐大學 Shih Chien University
馬德宇、韋宗坡、魏士杰 De-Yu Ma, Zong-Po Wei, Shi-Jie Wei	巧取 Easy Unplug	中國大陸 China	大連民族大學 Dalian Nationalities University
趙忠文、楊揚、林子傲 Zhong-Wen Zhao, Yang Yang, Zi-Ao Lin	共同呼吸 Breathe Together	中國大陸 China	大連民族大學 Dalian Nationalities University
楊帥、文懷奇 Shuai Yang, Huai-Qi Wen	多功能安全護欄 Multi-Function Safety Barrier	中國大陸 China	遼寧工業大學 Liaoning University of Technology
Dylan Sheppard, David Chapman	The Urban Yield	澳洲 Australia	昆士蘭科技大學 Queensland University of Technology
陶俊蓉 Chun-Jung Tao	植生磚 Green Slab	臺灣 Taiwan	國立臺灣科技大學 National Taiwan University of Science and Technology
Ciara Little	A/B/O: Blood Bags	英國 United Kingdom	雪菲爾哈倫大學 Sheffield Hallam University

69 入選 Finalist



## 102 Gold Prize 金獎

作者姓名 Name of Designer(s)	作品名稱 Title of Work	學校所在地 Location of School	學校名稱 Name of School
黃聖軒、吳承諭 Sheng-Syuan Huang, Cheng-Yu Wu	字蹟 Finding Taiwan Old Street_ Three Scenic Views of Lukang	臺灣 Taiwan	亞洲大學 Asia University

## 104 Silver Prize 銀獎

作者姓名 Name of Designer(s)	作品名稱 Title of Work	學校所在地 Location of School	學校名稱 Name of School
姚凱倫 Kai-Lun Yao	數說年齒 Title of Age in Ancient China	中國大陸 China	中國美術學院上海設計學院 Shanghai Institute of Design- China Academy of Art

## 105 Bronze Prize 銅獎

作者姓名 Name of Designer(s)	作品名稱 Title of Work	學校所在地 Location of School	學校名稱 Name of School
朱天航 Tian-Hang Zhu	鄰居的耳朵線上音樂平臺一線下音樂會視覺設計 Neighbor's Ear Vision Design	中國大陸 China	南京藝術學院 Nanjing University of the Arts
林捷均、楊采廷、楊雅筑 Jie-Jun Lin, Tsai-Ting Yang, Ya-Chu Yang	小日字 Shiou Li Ji	臺灣 Taiwan	南臺科技大學 Southern Taiwan University of Science and Technology
鄒云岱 Yun-Dai Zou	生機 Give Your Life a Chance	臺灣 Taiwan	亞洲大學 Asia University

## 108 佳作 Honorable Mention Prize

作者姓名 Name of Designer(s)	作品名稱 Title of Work	學校所在地 Location of School	學校名稱 Name of School
黃昶維 Chang-Wei Huang	言論自由 Freedom of Speech	臺灣 Taiwan	崑山科技大學 Kun Shan University
Jens Marklund	Typecon Identity	美國 United States of America	紐約視覺藝術學院 School of Visual Arts
陳彥霏 Yan-Fei Chen	保護女性軀體 Protect Female Body	中國大陸 China	廈門大學 Xiamen University
李夢丹 Meng-Dan Lee	Opportunity	中國大陸 China	福州大學廈門工藝美術學院 Xiamen Academy of Arts and Design, Fuzhou University
崔雄智 Xiong-Zhi Cui	礫塵體 Gravel Dust	中國大陸 China	吉林藝術學院 Jilin University of the Arts
林俊銘 Chun-Ming Lin	山水 Landscape	臺灣 Taiwan	弘光科技大學 Hungkuang University
顏敬安、高在芹、楊芷綾、趙于婷 Jing-An Yan, Zai-Cin Gao, Chin-Ling Yang, Yu-Ting Chao	石獅錄 - 金門風獅爺圖鑑 Kinmen Wind Lion God-Guide Book	臺灣 Taiwan	中國科技大學 China University of Technology
吳雙 Shuang Wu	無 None	臺灣 Taiwan	亞洲大學 Asia University

## 116 入選 Finalist

## 188 Gold Prize 金獎

作者姓名 Name of Designer(s)	作品名稱 Title of Work	學校所在地 Location of School	學校名稱 Name of School
盤思妤、陳昭名、陳聖勛 Sz-Yu Pan, Zhou-Ming Chen, Sheng-Hsun Chen	霓虹 Neon	臺灣 Taiwan	國立臺灣藝術大學 National Taiwan University of Arts

## 190 Silver Prize 銀獎

作者姓名 Name of Designer(s)	作品名稱 Title of Work	學校所在地 Location of School	學校名稱 Name of School
Yosuke Tani	The Fire Celebration at Kurama	日本 Japan	東京藝術大學 Tokyo University of the Arts

## 191 Bronze Prize 銅獎

作者姓名 Name of Designer(s)	作品名稱 Title of Work	學校所在地 Location of School	學校名稱 Name of School
Jihyeon Bae	Flipped Out	美國 United States of America	紐約視覺藝術學院 School of Visual Arts
楊凱雲、王培萍、花婉齊 Kai-Yun Yang, Yu-Ping Wang, Wan-Ci Hua	蛋蛋的煩惱 Go Nuts	臺灣 Taiwan	國立臺灣藝術大學 National Taiwan University of Arts
周浩然 Harry Zhou	Harry	中國大陸 China	同濟大學 Tongji University

## 194 佳作 Honorable Mention Prize

作者姓名 Name of Designer(s)	作品名稱 Title of Work	學校所在地 Location of School	學校名稱 Name of School
Young Gul Cho	E-Delivery	美國 United States of America	紐約視覺藝術學院 School of Visual Arts
林書彥 Shu-Yen Lin	盲蟲 Blindly	臺灣 Taiwan	崑山科技大學 Kun Shan University
王靖婷、張秋月、陸韓英 Jing-Ting Wang, Qiu-Yue Zhang, Han-Ying Lu	補月者 Fill the moon	中國大陸 China	中國美術學院 China Academy of Art
張晉璋、齊慕夷、羅健銘 Jin-Wei Chang, Mu-Yi Chi, Chien-Ming Lo	來個冰淇淋 Want Some Ice Cream	臺灣 Taiwan	大同大學 Tatung University
余聿 Yu Yu	家家酒 PlayHouse	美國 United States of America	南加州大學 University of Southern California
張素華、鄭欣佩 Su-Hwa Chang, Sin-Pei Jheng	沉默的牆 Wall	臺灣 Taiwan	國立雲林科技大學 National Yunlin University of Science and Technology
黃靜、賈麗琦 Eva Huang, Jane Jia	以上 Above the Cloud	中國大陸 China	西安美術學院 Xi'an Academy of Fine Arts

## 201 入選 Finalist

210 財團法人看見台灣基金會 / 財團法人溫世仁文教基金會  
iSee Taiwan Foundation / Sayling WenCultural & Educational Foundation

## 廠商指定看見台灣基金會創新設計獎 — Brand Specified - iSee Taiwan Foundation Innovative Design Awards

## 216 Gold Prize 金獎

作者姓名 Name of Designer(s)	作品名稱 Title of Work	學校所在地 Location of School	學校名稱 Name of School
李貞儀 Chen-Yi Lee	製餅食茶 TeaLab	臺灣 Taiwan	實踐大學 Shih Chien University

## 218 Silver Prize 銀獎

作者姓名 Name of Designer(s)	作品名稱 Title of Work	學校所在地 Location of School	學校名稱 Name of School
張玉樺、呂淑惠 Yu-Hua Jhang, Shu-Hui Lu	80 at-tea 收納式多功能茶具組 80 at-tea Admission Multifunction Tea Set	臺灣 Taiwan	亞東技術學院 Oriental Institute of Technology
田文成、薛邁 Wen-Cheng Tian, Mai Xue	山・茶事 Mountain・Tea Affairs	中國大陸 China	安陽工學院 Anyang Institute of Technology

## 220 Bronze Prize 銅獎

作者姓名 Name of Designer(s)	作品名稱 Title of Work	學校所在地 Location of School	學校名稱 Name of School
蕭翎軒 Ling-Xuan Xiao	原源不絕 Uninterrupted Flow	臺灣 Taiwan	亞洲大學 Asia University
李玟函 Wen-Han Li	看見 I See	臺灣 Taiwan	亞洲大學 Asia University
徐瑄惠、黃弘宇 Hsuan-Hui Hsu, Hung-Yu Huang	客器 - 五件式茶具組 Kochi Tea Set	臺灣 Taiwan	中華大學 Chung Hua University
姜標、王新元、李嘉良、陳靜 Biao Jiang, Xin-Yuan Wang, Jia-Liang Li, Jing Chen	若 / 茶則 If/tea	中國大陸 China	上海視覺藝術學院 Shanghai Institute of Visual Arts

## 224 佳作 Honorable Mention Prize

作者姓名 Name of Designer(s)	作品名稱 Title of Work	學校所在地 Location of School	學校名稱 Name of School
朱璟欣、謝佳穎、潘思濂 Jing-Xin Choo, Jia-Ying Chia, Si-Hui Fua	寶島印象 The Impression of Taiwan	馬來西亞 Malaysia	達爾尚藝術學院 Dasein Academy of Art
林子翔 Tzu-Hsiang Lin	手搖。新食器 Shake! New Tea Bottle	臺灣 Taiwan	國立雲林科技大學 National Yunlin University of Science and Technology
呂俊翰 Jun-Han Lu	曲 Curve	臺灣 Taiwan	南臺科技大學 Southern Taiwan University of Science and Technology
賴玄、王思卿 Xuan Lai, Si-Qing Wang	呼吸 Breathing	中國大陸 China	福州大學廈門工藝美術學院 Xiamen Academy of Arts and Design, Fuzhou University
湯睿峰、劉耀鍾 Jui-Feng Tang, Yao-Chung Liu	山中香，湖中水 Aroma from the Mountain, Taste from the Lake	臺灣 Taiwan	國立臺灣科技大學、國立臺灣藝術大學 National Taiwan University of Science and Technology、 National Taiwan University of Arts

尚爽 Shuang Shang	老商標新創意 Translate Legacy Logo into State of The Art-Cultural Creative Product Design	中國大陸 China	南京藝術學院 Nanjing University of the Arts
林姿妤、林總蘋 Zih-Yu Lin, Si-Pin Lin	回甘好麻吉 Aftertaste Buddies	臺灣 Taiwan	亞洲大學 Asia University

231 入選 Finalist

## 評審簡介 Jury Introduction

246 產品設計 Product Design

251 視覺設計 Visual Design

256 數位動畫 Digital Animation

## 活動紀實 On the Spot

264 初選紀實 Preliminary Selection

268 決選紀實 Final Selection

272 參賽作品件數分析表 Entries Statistics

274 設計講座 Design Seminar

278 頒獎典禮紀實 Award Ceremony

290 展覽紀實 Exhibition

292 新亞洲設計工作坊 New Asia Design Workshop

294 海內外歷屆作品展覽 Domestic and International Exhibitions

298 大賽人員介紹 Staff Introduction

## 附錄－競賽簡章 Appendix - Competition Regulation

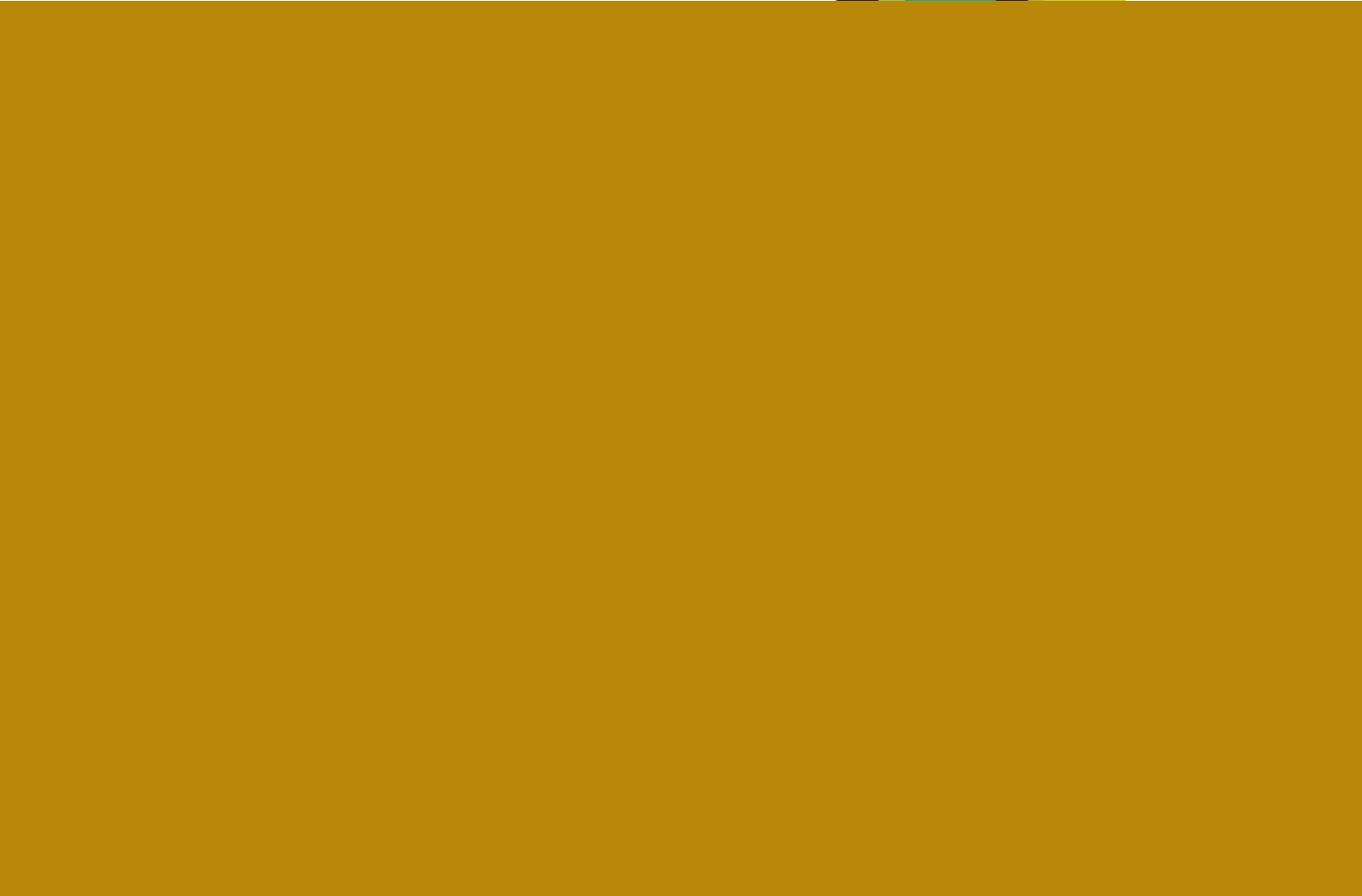



2017

# Opportunity

序

Preface

## 序 | 教育部部長

### 面對未來挑戰、選擇多元機會、整合豐富資源、創造無限價值

---

面臨全球化與急遽改變的挑戰，如何善用多元的機會將資源整合，激發出蓬勃的創作力與競爭力，是未來的重要課題。本部以教育驅動人文思辨的核心價值，啟發青年學子創造設計力量，藉由舉辦國際級的設計盛事，提供青年學子多元的機會及與國際設計接軌機會，並結合新南向政策，引入多樣元素，幫助臺灣創意設計能量在地扎根，放眼國際，創造更大的效益。

臺灣國際學生創意設計大賽自 2008 年起開始舉辦，今年已邁入第十年，目的是為鼓勵全球青年學子創意交流，培養學生設計思考力，建構一個設計實踐的平臺。歷經十年來的耕耘，今年收件數較去年增加約 4,000 件，共計有 71 個國家及地區共 18,932 件作品參賽，最後共選出 68 件得獎作品。今年的報名件數與參加國家地區數都創下歷屆新紀錄，臺灣國際學生創意設計大賽已是全球規模最大、獎金最高的國際學生設計競賽，亦顯示本大賽在全球設計領域已有一定之影響力。

在「財團法人看見臺灣基金會」與「財團法人溫世仁文教基金會」共同支持下，今年國際設計組織特別獎增加至 16 個，分別為 AFD 法國設計師聯盟、SBB 捷克布魯諾雙年展協會、DBCS 新加坡設計業總商會、GDA 澳大利亞優良設計協會、GDC 德國國家設計委員會、FHKDA 香港設計總會、ico-D 國際設計社團協會、IDC 印度設計委員會、IPBM 墨西哥國際海報雙年展協會、JDP 日本設計振興會、KECD 韓國現代設計協會、MDA 澳門設計師協會、TCDC 泰國創意設計中心、tDA Asia 亞洲設計連、TDC 台灣創意設計中心及 DINZ 紐西蘭設計師協會等組織，透過這些組織自行推派成員來臺擔任評審，並親自授獎，給予得獎學生鼓勵與肯定，期許國際評審帶來新思維，激盪出更寬廣的新視野，提升設計的創意，並思考如何在未來創造加值的合作。

此次活動也要感謝亞洲大學的執行團隊和來自國內外評審委員們不辭辛勞的努力付出，及國際設計組織的大力協助與支持，讓 2017 年臺灣國際學生創意設計大賽創下新的里程碑。期盼所有參與的青年學子，未來能夠蛻變為具國際觀的設計菁英，用設計的力量改變世界，創造屬於個人和臺灣獨特的設計實力。

教育部 部長

潘文忠

## Perface | Minister of Education

### Facing Future Challenges, Choosing Diverse Opportunities, Integrating Rich Resources, and Creating Infinite Value

---

Faced with the challenges of globalization and rapid changes, we need to be able to leverage diverse opportunities, integrate resources, and unleash vibrant creativity and competitiveness, all of which are important issues for the future. Through education, our Ministry aims to drive and uphold the core value of humanity and critical thinking, hoping to inspire the design and creative power of the youth. By organizing such an international design event, we provide young students with diverse opportunities and connections to the global design world. We also combine the event with the New Southbound Policy and introduce a variety of elements to it, seeking to help Taiwan's creative and design power to root locally and stand globally, which will generate stronger impact as a result.

Taiwan International Student Design Competition was initiated in 2008, and this year marks its tenth anniversary. The objective is to encourage the youth of the world to carry out exchanges on creativity, cultivate students' design thinking, and establish a platform for design practice. After ten years' efforts, the number of received entries this year has grown by about 4,000 pieces compared to last year. In total, 71 countries/regions, with 18,932 entries, participated in the Competition, and 68 works were finally selected to win the awards. This year, both the number of entries and that of participating countries/regions have achieved new records. Taiwan International Student Design Competition is already the largest-scale international student design competition worldwide with the largest reward sums, which indicates that it already exerts a certain level of influence in the global design field.

With the joint support of iSee Taiwan Foundation and Sayling Wen Cultural & Educational Foundation, the number of International Design Association Special Prizes has increased to sixteen this year, which are from: Alliance française des designers (AFD), Sdružení Bienále Brno (SBB), Design Business Chamber Singapore (DBCS), Good Design Australia (GDA), German Design Council (GDC), Hong Kong Federation of Design Associations (FHKDA), International Council of Design (ico-D), India Design Council (IDC), International Poster Biennial of Mexico (IPBM), Japan Institute of Design Promotion (JDP), Korea Ensemble of Contemporary Design (KECD), Macau Designers Association (MDA), Thailand Creative & Design Center (TCDC), the Design Alliance Asia (tDA Asia), Taiwan Design Center (TDC) and Designers Institute of New Zealand (DINZ). These associations delegated their members to Taiwan to serve as Competition jurors and deliver the Special Prizes in person. They not only provided encouragement and acknowledgement to the award-winning students but also brought new thinking, broadened new horizon, enhanced design creativity, and contemplated how to create value-adding cooperation in the future.

For this event, gratitude goes to the arduous efforts of the executive team at Asia University, to all the jurors from home and abroad, and to the tremendous assistance and support of the international design associations. These efforts have allowed 2017 Taiwan International Student Design Competition to reach new milestones. It is hoped that all the participating young talent will become design elite with international vision in the future, and they are expected to use the power of design to change the world and create design strengths that are unique to themselves and to Taiwan.

Minister of Education





## 序 | 計畫主持人

### Opportunity 面對挑戰，創造機會

#### 國際指標，全球規模

臺灣國際學生創意設計大賽由教育部從 2008 年首度舉辦，發展至今已邁入第十年。大賽的國際曝光率逐年增加，作品參賽數也呈現持續穩定成長的狀態，今年的報名參賽人數再創新高，收到來自全球 71 個國家地區、910 個校院系所參賽，總計有 18,932 收件作品的規模數量，較 2016 年之作品收件數量成長 27.3%，其中非臺灣院校報名的數量高達 63%。若從國家數、學校數、作品數及國際化比率等各項指標均已經達到歷屆之最，並且這些量化指標已經超越今年同屬提供學生競賽的德國 iF 設計新秀獎之 10,625 件、德國紅點概念設計獎之 7,838 件的規模，更可謂是全世界最具規模化與公信力，且專屬於學生的設計賽事；也正因為這樣的量化指標，奠定了本項大賽未來朝向更高目標國際性品牌發展的堅實基礎，也增加執行團隊持續奮進的無比信心。

#### 溝通視窗，合作橋樑

今年作品件數的激增與活動內容的擴充，首先要感謝教育部青年發展署繼續支持本項具有國際化的青年學生活動，並開拓新南向政策，讓本項大賽有機會將設計教學經驗輸出與越南、馬來西亞、新加坡及寮國交流，明年將增加資源並繼續深耕與南向國家的交流平台，以及保持本大賽的競爭力；另外特別要感謝看見台灣基金會與溫世仁文教基金會的大力支持與資金贊助，除了在原有的臺灣國際學生創意設計大賽的基礎之上，擴大成為 16 個國際設計組織結盟的全球合作夥伴關係、增加了新亞洲設計工作坊、國際設計大師論壇、全球青年設計工作坊、全球設計領袖論壇、D21 全球設計組織高峰會議以及邀請國際貴賓進行臺灣文化巡禮與產業對接的深度之旅…等系列活动而將設計大賽擴大成為全球青年設計大會，從原本設計大賽只是單純的競爭角逐，發展成促進全球設計族群聚會交流的窗口，提供國際師生分享經驗的合作平台，也成功地塑造出一個讓獲獎學生得以充分感受到無限榮耀的舞台。

#### 國際公認，全球結盟

檢視今年臺灣國際學生創意設計大賽的發展成果，其中至關重要的是持續擴大本大賽在全球結盟的布局有來自 AFD 法國設計師聯盟、BBA 捷克布魯諾設計雙年展協會、DBCS 新加坡設計行業總商會、GDA 澳大利亞優秀設計獎、GDC 德國國家設計委員會、FHKDA 香港設計總會、ico-D 國際設計社團協會、IDC 印度設計委員會、IPBM 墨西哥國際海報雙年展協會、JDP 日本設計振興會、KECD 韓國現代設計協會、MDA 澳門設計師協會、TCDC 泰國創意設計中心、tDA Asia 亞洲設計連、TDC 台灣創意設計中心及 DINZ 紐西蘭設計師協會等組織共有 16 個國際設計組織簽署授權合作，並且同意以該組織名義設置了 16 國際個設計組織命名的特別獎項之外；另外除了在各自所屬的國家協助推廣宣傳並且指派設計代表擔任大賽評審委員，如此不僅擴大評審團成員也提供更佳多元的評審觀點，豐富本項大賽兼容全球化與多樣性的特色；國際結盟網絡所帶給全球設計校院師生的信賴感與權威性，不僅造成了今年報名作品數量倍增成長，另外也吸引了更多國際知名設計院校積極報名參賽，促使獲得獎項的作品品質大幅地提升，將臺灣的設計教育、大賽品牌推廣、人才培育推向更國際化，並樹立臺灣成為世界執行設計教育的典範與標竿。

#### 創造機會，迎向未來

臺灣國際設計比賽是值得年輕學生設計師角逐與追求的榮譽獎項，最後感謝歷年所有報名參賽的校院系所師生，因為所有的成果都是來自大家的共同參與所創造的；另外也要藉此特別感謝亞洲大學執行團隊讓這個僅有十年歷史的賽事，能夠快速地成長與締造出令人欣慰的佳績；每年看著來自全球的獲獎學生展現出青春無限、創意無疆的成果，這正是未來改變世界的創意力量之所在；期待明年臺灣國際學生創意設計大賽主題「突破與創新 Break Through & Innovation」，能夠繼續帶領全球設計院校師生共同創造機會、把握良機、迎向未來！

計畫主持人



### **An International Leader with a Global Scale**

Taiwan International Student Design Competition (TISDC) was initiated by the Ministry of Education in 2008, and this year marks its tenth anniversary. Every year, the Competition's international visibility has been increasing, and the number of participating entries has been growing steadily, too. This year, the number of participants reached a new high, with a total of 18,932 entries from 910 school departments/institutes of 71 countries/regions around the world, which represents a growth of 27.3% from 2016. Among all the entries, those from outside of Taiwan account for as high as 63%. If we look at the different indicators such as the number of countries, schools, entries and the international participation rate, this year was indeed the highest ever. What's more, such a scale has already surpassed the 10,625 entries of iF Design Talent Award and the 7,838 entries of Red Dot Design Award for Design Concept, both of which are open for students. It is fair to say that TISDC is the largest-scale and the most credible design competition worldwide that is dedicated to students. Due to such quantitative indicators, the Competition can now enjoy a solid foundation for reaching a higher goal of developing its international brand, and great confidence can be instilled in the executive team when it moves ahead.

### **As a Communication Window and a Cooperation Bridge**

For the rapid increase of entries and the growing diversity of events this year, gratitude has to first go to the Youth Development Administration of the Ministry of Education. They continue to support this international youth activity and implement the New Southbound Policy, which has allowed the Competition to have a chance to share design education experience with Vietnam, Malaysia, Singapore and Laos. Thanks to the Administration, the Competition is expected to increase resources next year to keep strengthening the exchange platforms with Southeast Asian countries as a way to maintain its competitiveness. Gratitude also goes to the strong support and financing of iSee Taiwan Foundation and Sailing Wen Cultural & Educational Foundation. Based on the original TISDC model, the two Foundations have formed global partnerships with 16 international design associations, added a variety of events (such as New Asia Design Workshop, Global Design Masters Forum, Global Youth Design Workshop, Global Design Leadership Forum and D21 Global Design Associations Summit) as well as invited international guests to cultural tours and industry dialogues in Taiwan. All of these efforts have enlarged TISDC and turned it into a global youth design gathering. TISDC was simply a competition when it began, but now, it has become a window of exchange for design associations from around the world. It provides a collaboration platform for international teachers and students to share experience together, and it has successfully created a stage of honor for the award-winning students to feel proud of themselves.

### **International Recognition and Global Alliances**

Among the development achievements of TISDC this year, one crucial element is that the Competition continues with its extension of global alliances: Alliance française des designers (AFD), Sdružení Bienále Brno (SBB), Design Business Chamber Singapore (DBCS), Good Design Australia (GDA), German Design Council (GDC), Hong Kong Federation of Design Associations (FHKDA), International Council of Design (ico-D), India Design Council (IDC), International Poster Biennial of Mexico (IPBM), Japan Institute of Design Promotion (JDP), Korea Ensemble of Contemporary Design (KECD), Macau Designers Association (MDA), Thailand Creative & Design Center (TCDC), the Design Alliance Asia (tDA Asia), Taiwan Design Center (TDC) and Designers Institute of New Zealand (DINZ). These 16 international design associations have signed the cooperation on licensing with the Competition and agreed to set up 16 International Design Association Special Prizes in their names. In addition to promoting TISDC in their home countries, these associations also delegate representatives to serve as jurors for the Competition. This not only enlarges the size of the jury panel and provides more diverse viewpoints but also strengthens the internationality and diversity as the features of the Competition. For design teachers and students worldwide, such global alliances have enhanced the credibility and authority of TISDC. As a result, the number of participating entries has grown significantly this year, and more and more globally renowned design schools have been attracted to actively participate. The quality of the award-winning works has been largely enhanced, while Taiwan's design education, talent cultivation and the branding of TISDC have been further internationalized, with Taiwan as the norm and benchmark worldwide in the implementation of design education.

### **Notes on the achievements of 2017 Taiwan International Student Design Competition**

TISDC is an honorable award worth the participation and pursuit of young design students. Last but not least, gratitude goes to all the participating students and their instructors throughout the years because all the achievements have been created by the participation of every one of you collectively. In addition, special thanks go to the executive team at Asia University, which has made it possible for this Competition with only ten years of history to grow rapidly and make much appreciated achievements. Every year, when seeing the award-winning students from around the world display their design results with infinite young energy and creativity, I am sure that this is where we find the creative power that will change the world in the future. It is expected that the theme of TISDC next year, "Break Through & Innovation," will continue to lead design teachers and students worldwide, encouraging them to create opportunities, seize the moment and embrace the future together!





2017

# Opportunity

---

年度大獎

Grand Prix

## 年度大獎 Grand Prix

### 年度大獎評審評語 Jury Comments on Grand Prix



鍾雅涵 Kate Chung | 臺灣 Taiwan

#### 評審講評 Jury Comments

本次比賽主題為 Opportunity，我認為這件作品是在一個危急的狀態之下，便可以提供人們一個很好的求生機會。在火災中被濃煙嗆傷而造成死傷的比例相當高，若遭遇火災時，當下除了等待消防人員搶救，自救的方式就是避免濃煙的嗆傷，若此裝置能放置在消防器材旁邊，則能夠減少許多死傷的機會。

The theme of this Competition is "Opportunity", and I believe that in an emergency, this product can provide people with a good opportunity of survival. In fire disasters, the rates of mortality and injury caused by choking on smoke are quite high. Therefore, if a fire strikes, apart from waiting for firefighters for rescue, one way to save ourselves is to avoid choking on smoke. If such a device can be put next to fire extinguishers, then it will be able to prevent many casualties.



Brandon Gien | 澳洲 Australia

#### 評審講評 Jury Comments

我認為這件作品非常棒，它不僅符合了這次大會指定的評審原則之外，另外實際解決我們現實生活的問題，這個設計不只是具有原創性且是十分聰明的設計，此外，它呈現設計的解說方法是相當專業，大部分的設計可能無法清楚的說明本身的理念，但是這件作品清楚的闡述創作者的設計概念。再來就是結構的部分，我們在面臨緊急狀況的時候，人們是沒有時間閱讀手冊，因此我們需要的是直覺性、迅速的運作方式，所以它的設計符合了這個需求要件，一件好的設計可以拯救一個生命，我想這件作品能夠拯救千千萬萬無數個生命。

I think this work is very great. It not only meets the judging criteria assigned by the Competition but also solves the real problems in our lives. The design is not only original but also quite smart. In addition, the way the explanations are displayed is very professional. Most design works may not be able to clearly explain the concepts behind, but this entry clearly explains the creators' design concepts. As for the structure, when we are faced with an emergency, we don't have time to read a manual, so we need intuitive and fast operation. The design of this entry meets such a need. A good design saves one life, and I believe that this work will be able to save thousands and thousands of lives.



Hridaysh Deshpande | 印度 India

#### 評審講評 Jury Comments

這是一個針對於緊急火災時可以使用的設備，特別是對高樓層的建築物來說更是重要，它的安裝使用的方式都相當簡單且容易維護又不易損壞，以上是我給此件作品的高度肯定的原因。

This is a device that can be used in a fire emergency, and it is especially crucial for tall buildings. The installment and usage are quite easy, and its maintenance is simple since it doesn't get damaged easily. These are the reasons why I highly acclaim this work.







青木史郎 **Shiro Aoki** | 日本 Japan

評審講評 Jury Comments

我認為此件作品的優點在於創作者很仔細的觀察緊急的時候必須要注意的事項，他考量到了在緊急的時刻人們並無法以鎮定的態度去處理事情，當無法從容面對時，行動上應該要怎麼去補強，是創作者考量到的重點。以下是創作者考量周全的兩大特點，首先，他注意到口罩溼式會比乾式更加適合；再來，當人在面臨緊急危難時，需要使用逃生用具時是相當慌張，因此有了簡易的救難裝置並可大大增加生存機會。總括上述觀點，這是一件實屬難得的好作品。

I think the strengths of this work lie in the fact that the designers very carefully observe what needs to be considered in an emergency. They take into account that in an emergency, people cannot possibly calm down and cope with the situation. As a result, the key point for the designers is to compensate for such inability to be calm with this product. Here are two main features of the designers' thorough considerations. First, they notice that dampened masks are more suitable than dry ones. Second, faced with a crisis of emergency, people tend to panic when having to use life-saving devices, so simple usage can largely increase the likelihood of survival. To sum up, this is indeed an extraordinary and precious piece of work.



孫善蓉 **Steffy Sun** | 臺灣 Taiwan

評審講評 Jury Comments

這是有主題性的比賽，所以年度大獎除了要有很好的創意外，還跟隨到今年主題的精神，今年優秀的作品相當多，但這件作品勝出是因為它有完全契合 Opportunity 的訊息，就好比遭遇災難或是緊急救難時，給人們生命另外一個生存機會，加上創作者提出的解決方式我認為是前所未見。在遭遇緊急的狀態下，一個簡單的反射動作就可以將救難裝置組合完成，這個概念是相當聰明，實至名歸。

This is a themed competition, so the Grand Prix winner requires not only outstanding creativity but also connection to the spirit of the theme this year. There are quite a few excellent entries this year, but this work has won because it perfectly corresponds to the message of "Opportunity"—when a disaster or an emergency strikes, it can provide an opportunity of survival for the lives of people. Besides, I believe that the solution put forward by the designers has never been seen before. In an emergency situation, a simple and intuitive move can already complete the assembling of the rescue devices. Such an idea is very smart indeed and definitely deserves the prize.



鄭道成 **Do Sung Chung** | 韓國 Korea

評審講評 Jury Comments

現今安全事故頻傳，此作品是能自動地讓人們繼續呼吸的一個裝置，從作品看來，它呈現出不只是設計師累積至今的一個產品設計經驗，它更是賦予了設計能夠在人們安全和生活問題上，扮演舉足輕重的一個好作品。在未來若是有越來越多具有相同特性的作品問世，便能建立出一個使用者皆能安全生活的社會狀態。

Nowadays, safety incidents are quite common. This work is a device that allows people to continue to breathe in a disaster. This entry not only shows the accumulated product design experience of the designers but also represents a good piece of work that allows design to play an indispensable role in the issues of people's safety and life. If there are more and more works with such characteristics that are created in the future, then we will be able to build a society in which all the users can live safely.



## Water Mask Dispenser

作者姓名 Name of Designer(s)  
 Hyunsu Park、Hyungjun Koo、  
 Jaeyon Kim、Seonggon Jin、  
 Minseop Woo、Hanna Lee、  
 Chanmi Kim、Wansik Jang

指導老師 Instructor(s)  
 無  
 None

學校所在地 Location of School  
 韓國  
 Korea

學校名稱 Name of School  
 國民大學  
 Kookmin University



### 作品說明 Project Description

這是一道緊急裝置，在火災發生時能夠拯救民眾的性命。在火災演習中，我們學習到的逃生方法之一是拿濕毛巾遮掩口鼻。然而，在捷運、辦公室和學校裡頭有時很難找到水源，而戴上防毒面具又很花時間。透過這個濕面罩供應裝置，只要「拉」一下就有機會拯救許許多多的生命。

Emergency device that can save people's lives in the event of fire. One of the fire drill methods is to cover your nose and mouth with the wet towel. But it's hard to find water in the subway, office, and school, also it takes long time to wear gas mask. Water mask dispenser is able to save lots of lives with just one "pulling" motion.



### Solution





Pull the doorknob with a powerful motion.

The lid that's connected to the doorknob will wet the masks.

Quickly share and wear the masks.

It contains 20 masks, so it's enough to share.



Cover your nose and mouth, and quickly get out from the area.

Wet mask can efficiently block the toxic gas.

### How to use



Pull the door

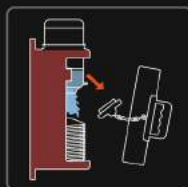

The water will be poured when you open the door



Wear the wet mask







2017

# Opportunity

國際設計組織特別獎

International Design Association Special Prize

### 十六個國際設計組織介紹 Sixteen International Design Associations



法國設計師聯盟  
Alliance Francaise des Designers

法國設計師聯盟 (AFD) 是法國最大的設計師工會，它是為獨立的設計師、公司老闆或者是各個領域 (信息、產品、空間) 的全職設計師成立共同基金。AFD 很重視設計行業的保護和完善，它致力於認可正式設計師的頭銜，打造一個質量標籤的流程。法國設計師聯盟 (AFD) 在法國不斷地分享設計的信息，AFD 在歐洲和全世界，一直是設計師專業組織的最好合作夥伴，在經濟、環境、文化問題上，進行設計溝通，採取共同的行動。

The Alliance Francaise des Designers is recognized by the French public authorities. Having in mind to constantly modernize the designers' status, the AFD cooperates on everyday basis with the Ministries of Industry, of Culture and of Social Affairs. They give priority to the protection and the enhancement of the design professions by working on the recognition of an official designer title and by developing a process of quality labels. Like any other profession willing to play a meaningful role in the society, ours gets organized to unite individuals, whether they are independent professionals, company owner or in-house designers. The AFD aims to gain more visibility and understanding from the different design stakeholders and the local and regional public authorities. Working with designers organizations across Europe, they participate in spreading ideas to help European authorities to establish the more efficient design policy and the fair legislation.



捷克布魯諾雙年展協會  
Brno Biennale Association

1963 年，捷克斯洛伐克視覺藝術家聯合會 (Union of Czechoslovak Visual Artists, SCVU) 與摩拉維亞美術館 (Moravian Gallery in Brno)，共同舉辦全世界第一場國際平面設計比賽。自此之後，該項比賽獲得捷克共和國文化部與布魯諾市的策劃贊助。1991 年起，布魯諾雙年展協會取代 SCVU 的地位，成為溝通設計的專業組織，協會會員集中於捷克共和國與斯洛伐克，其他國家亦有榮譽會員。

In 1963, the Union of Czechoslovak Visual Artists (SCVU) and the Moravian Gallery in Brno co-founded the world's first international graphic design competition, "The International Biennale of Graphic Design in Brno". Since that, it has been organized with the patronage of the Ministry of Culture of the Czech Republic, and the City of Brno. Since 1991, the Brno Biennale Association (SBB) has replaced the role of the SCVU, and it became a professional organization of communication design, which concentrates members in the Czech Republic, Slovakia, and honorary members also in other foreign countries.



新加坡設計業總商會  
Design Business Chamber Singapore

新加坡設計業總商會 (DBCS) 成立於 1985 年，為新加坡主要跨領域的設計商務中心，其成員由超過 190 位的商業菁英、專業人士與學術人才組成的多元背景。本協會也是年度新加坡優良設計標誌獎 (Singapore Design Awards) 的主辦單位，提供了能自由揮灑創造力的完善平台與獎項，讓新加坡與鄰近地區的傑出企業與優秀設計師一展設計長才。DBCS 旨在透過跨區域的國際合作提升設計力並創造新商機。

With its roots dating back to 1985, Design Business Chamber Singapore (DBCS) is Singapore's premiere multidisciplinary design business chamber, with a dynamic community of over 190 business leaders, practitioners and academia from diverse backgrounds. The Chamber is also the organizer of the annual Singapore Design Awards (SDA). Providing a distinct / noticeable platform where creative excellence in the industry is celebrated, the premiere Awards event recognizes outstanding companies and exemplary designers behind the winning designs of Singapore and the region. DBCS seeks to raise the standard of professional practices and create new business opportunities through cross-collaborations in local and international contexts.



澳大利亞優秀設計協會  
Good Design Australia

澳大利亞優秀設計協會成立於 1958 年，六十年來持續堅持著推廣優秀設計的最終理念。本協會通過每年舉辦的優秀設計獎，以彰顯設計師匠心獨具的設計力，並激發設計新秀潛能。GDA 熱切地相信設計的變革力量，希冀創造出更完善、更有效的產品和服務，更美好的經驗和更具競爭力的企業。GDA 深信藉由設計，我們可以攜手創造出一個更美好且永續繁榮的世界。

Good Design Australia have been promoting great design since 1958. Through their annual Good Design Awards, GDA celebrates the best of human ingenuity and inspire others to reach for the sky and beyond. GDA passionately believes in the transformative power of design to create better and more efficient product and services, beautiful experience and more competitive businesses. Ultimately, GDA sees design contributing to a better society and a more sustainable and prosperous world for us all.



德國國家設計委員會  
German Design Council

德國設計委員會為全球頂尖專業設計機構之一，致力落實傳達與學術的設計力。目前已有超過280多間公司成為會員。德國設計委員會經德國聯邦議院之倡議而成立，旨在提升德國的設計水準。德國設計委員會長年舉辦跨領域活動之目的為傳達品牌永續的附加價值。

The German Design Council is one of the world's leading centres of expertise for communication and knowledge transfer in design. Currently, more than 280 companies belong to its foundation. The German Design Council was founded on the initiative of the German Bundestag to support and enhance the design expertise of German industry. It pursues a wide range of activities with a single goal: to increase brand value on a sustained basis via the strategic use of design in communication.



香港設計總會  
Hong Kong Federation of  
Design Associations

香港設計總會於2000年成立，旨在聯結香港各大設計協會及院校，其中包括英國特許設計師協會（香港）、香港設計師協會、香港工業總會（香港設計委員會）、香港時裝設計師協會、香港室內設計協會、香港各大設計院校代表等，以提升香港設計的專業水平。同時，香港設計總會亦參與香港設計中心的管理工作，為設計中心的營運及研發活動籌款及撥款。

The Hong Kong Federation of Design Associations (FHKDA) was founded in 2000 to connect major design associations and design schools in Hong Kong, including the Chartered Society of Designers (Hong Kong), the Hong Kong Designers Association, the Federation of Hong Kong Industries (Design Council of Hong Kong), the Hong Kong Fashion Designers Association, the Hong Kong Interior Design Association, and representatives of major design schools in Hong Kong, with a view to improving the level of professional design in Hong Kong. The FHKDA also manages the Hong Kong Design Center, and raises and appropriates funds for its operations and development.



國際設計社團協會  
International Council of Design

國際設計社團協會（ico-D）成立於1963年（前身為國際平面設計社團協會Icograda），本協會為非營利組織，藉由促進專業範疇、教育範疇與商業範疇會員間的交流而激發出頂尖的創造力。其核心價值與願景落實在ico-D會員間相互合作上的優勢，其會員為專業人士、跨領域組織、設計師等。其會員的交流相互作用，著重於當代社會的觀點思考與串聯全球及當地的多元社團。ico-D同時致力於推廣傑出的設計力與支持設計力作為推動社會的重要媒介。

Founded in 1963 as Icograda, the International Council of Design, ico-D, is a non-profit, non-partisan, member-based network that leads creatively by facilitating dialogue between design platforms including professional, educational and promotional categories.



印度設計委員會  
India Design Council

印度中央政府於2009年成立印度設計委員會，作為印度設計發展政策的第一步。其中32名成員由設計、學術、媒體、產業及政府部門的理事會等知名人士組成。IDC提供一個合適的平台，加強印度設計在全球的競爭力，引領國家設計方向，協調及整合各部門、機構和產業資源的推廣與發展。

In 2009, the central government of India founded the India Design Council (IDC) as a first step in its design development policies. The Council comprises 32 members from the design sector, academia, the media, industry, and government councils. The IDC provides a platform to improve India's global design competitiveness, to coordinate and integrate different sectors and institutions, and promote and develop industry resources.

## 國際設計組織特別獎 International Design Association Special Prize

### 十六個國際設計組織介紹 Sixteen International Design Associations



墨西哥國際海報雙年展協會  
International Poster Biennial in Mexico

墨西哥國際海報雙年展已有超過 23 年的歷史，主辦方和墨西哥最重要的文化機構合作並獲得了國際認證。墨西哥國際海報雙年展與芬蘭拉赫國際海報雙年展、波蘭華沙國際海報雙年展、日本富山國際海報展、美國科羅拉多國際海報展名列全球五大海報展，同時也是全球三大雙年展之一。

The International Poster Biennial in Mexico (IPBM) has a history of over 23 years. Its organizers cooperate with key cultural institutions in Mexico to gain international recognition. The IPBM ranks as one of the world's top five poster exhibitions alongside the Lahti Poster Triennial, the International Poster Biennale in Warsaw, the International Poster Triennial in Toyama, and the Colorado International Invitational Poster Exhibition. It is also one of the three largest global biennials.



日本設計振興會  
Japan Institute of Design Promotion

日本政府於 1969 年設立了日本產業設計振興會，以選拔優良設計做為主要目標，致力推廣設計。經過時間淬鍊，日本優良設計獎已成為國際知名的設計大獎；據統計，日本民眾對於此標誌的辨認度超過八成，由此可知優良設計與日本民眾的生活密不可分。是否獲得優良設計獎的肯定也成為消費者選購產品的一項考量因素，也因此日本設計振興會被認為是設計推廣組織當中最成功的案例之一。

The Japanese government established the Japan Institute of Design Promotion (JDP) in 1969 tasked with the selection of outstanding designs. Over time its outstanding design award has become an internationally famous design award and its design mark has become part of people's lives, with over 80% of Japanese being able to recognize it. The design mark has also become a decisive factor in consumer purchasing. As such, the JDP is recognized as one of the most successful design promotion organizations in the world.



韓國現代設計協會  
Korea Ensemble of Contemporary Design

韓國現代設計協會於 1969 年成立，隸屬於文化體育觀光部的法人團體組織，到目前為止共有 250 多名韓國設計相關學院的教授和專業設計師活躍於本協會。本協會也是韓國國內最早加入非營利平面設計權威組織－國際設計社團協會（International Council of Design: ico-D）的正式會員團體。

The Korea Ensemble of Contemporary Design (KECD) was founded in 1969, and is a juristic institution under the auspices of the Ministry of Culture and Tourism (South Korea). Currently, more than 250 professors and professional designers from Korean design schools serve in the association. The KECD is also the first Korean association to become an official member of the International Council of Design (ico-D).



澳門設計師協會  
Macau Designers Association

澳門設計師協會成立於 1986 年 5 月 18 日。是一個由平面設計師、產品設計師、室內設計師、網頁設計師、商業攝影師、插畫師等專業人士組成的綜合專業及非營利文化藝術團體。在過去三十年來為澳門“團結設計精英、維護業界利益、提昇專業水平、促進對外交流”孜孜不倦地努力。

Macau Designers Association (MDA) was founded on the 18th of May 1986. It's a professional and nonprofit cultural art association comprising graphic, product, interior and web designers, commercial photographers, illustrators and other creative professionals. In the last 30 years MDA has been sparing no effort to achieve the principle: "Unite Macau designers, protect industry profit and improve professionalism to further external exchange".







泰國創意設計中心

Thailand Creative & Design Center

泰國創意設計中心 (TCDC) 隸屬泰國總理府下轄的知識管理與發展辦公室 (OKMD)，2004 年 11 月於曼谷開幕，清邁分中心於 2013 年開幕。TCDC 是創意與設計的資源與資訊中心，致力推廣創意設計，讓泰國設計師與創業家的期待。TCDC 的蹤跡遍及全國，清邁與坤敬等大城市皆設有分中心，13 所位於校區內的 miniTCDCs 串聯起設計網絡。除此之外，2 家坐落於曼谷的 TCDC Commons 亦成為設計師的交流據點。日前曼谷 TCDC 遷至石龍君路的郵政大樓，已於 2017 年 5 月正式開幕。

TCDC is established as a resource and information center in creativity and design in Thai society to exceed the capacity of Thai designers and entrepreneurs. TCDC opened in Bangkok in November 2004 and in Chiang Mai in 2013 under the Office of Knowledge Management Development (OKMD) which is in turn part of the Office of the Prime Minister. TCDC Service is branching out to Chiang-mai, Khonkaen, miniTCDCs in 13 educational institutes in Thailand and 2 TCDC Commons for designer community in Bangkok. Recently, TCDC Bangkok relocated to The Grand Postal Building, Charoenkrung and soft launched to the public in May 2017.



亞洲設計連

The Design Alliance Asia (tDA Asia)

成立於 2000 年，亞洲設計聯盟 (tDA Asia) 集合了一群願景相同的亞洲設計師，致力推廣亞洲特色，欲以亞洲為核心凝聚一股活躍的文化力量，並將其作為設計的策略平台。tDA Asia 藉由共享同中存異的文化概念及知識，以提升亞洲設計師的原創性。tDA Asia 如今遍布 13 個亞洲國家或地區：中國、香港、印度、印尼、寮國、黎巴嫩 / 中東、馬來西亞、菲律賓、新加坡、南韓、臺灣、泰國及越南。

Founded in 2000, The Design Alliance Asia (tDA Asia) is a collaborative network of designers in Asia with a shared vision to advance Asian identity as a vital cultural force and a strategic platform for design. The organisation promotes the original creativity of Asian designers by sharing ideas and knowledge of our common yet diverse cultures. tDA Asia is currently represented in 13 Asian countries/regions: China, Hong Kong, India, Indonesia, Laos, Lebanon/Middle East, Malaysia, Philippines, Singapore, South Korea, Taiwan, Thailand and Vietnam.



台灣創意設計中心

Taiwan Design Center

創意設計是提升國家競爭力的重要關鍵，政府為推動文化創意產業發展，於 2003 年成立國家級設計中心「財團法人台灣創意設計中心」，並於 2004 年正式啟動營運。台灣創意設計中心之定位為臺灣創意設計發展的整合服務平台，其主要任務為提升設計人才原創能力、促進國際設計交流、加強產業市場競爭力並奠定企業發展自有品牌基礎，提高產業附加價值。

Creative design is the key to improving a country's competitiveness. As such, to promote the development of the cultural and creative industries, the Taiwan government set up a national design center in 2003, which began operations the following year. The TDC is positioned to serve as a service integration platform for the development of creative design in Taiwan. Its primary tasks include: upgrading the originality of design talent, promoting international design exchanges, enhancing industry competitiveness, building a base for enterprises to develop their own brands, and increasing industry added value.



紐西蘭設計師協會

The Designers Institute of New Zealand

紐西蘭設計學院是為紐西蘭設計界服務，並為其爭取利益。紐西蘭設計學院成立於 1991 年，由 1960 年成立的紐西蘭工業設計師協會，以及 1968 年成立的紐西蘭室內設計師協會合併而成。時至今日，其擁有的學門已十分廣泛，諸如：平面設計、互動設計、動態設計、空間設計、產品設計、商業設計、服務設計及設計教育等。專業設計師為紐西蘭帶來經濟、文化、社會層面的成長，紐西蘭設計學院的任務，則是確保專業設計師的貢獻夠獲得重視，並得到應有的報酬。

The Designers Institute of New Zealand exists to serve New Zealand's design community and represent its interests to the wider world. Formed in 1991, they grew from the merger of the New Zealand Society of Industrial Designers (formed 1960), and the New Zealand Association of Interior Designers (formed 1968). Today, they represent a much broader range of disciplines: graphic design, interactive design, motion graphics, spatial design, product design, design in business, service design and design education. The Designers Institute's mission is to make sure our professional designers are valued and rewarded for the contribution they make to the economic, cultural and social growth of New Zealand.

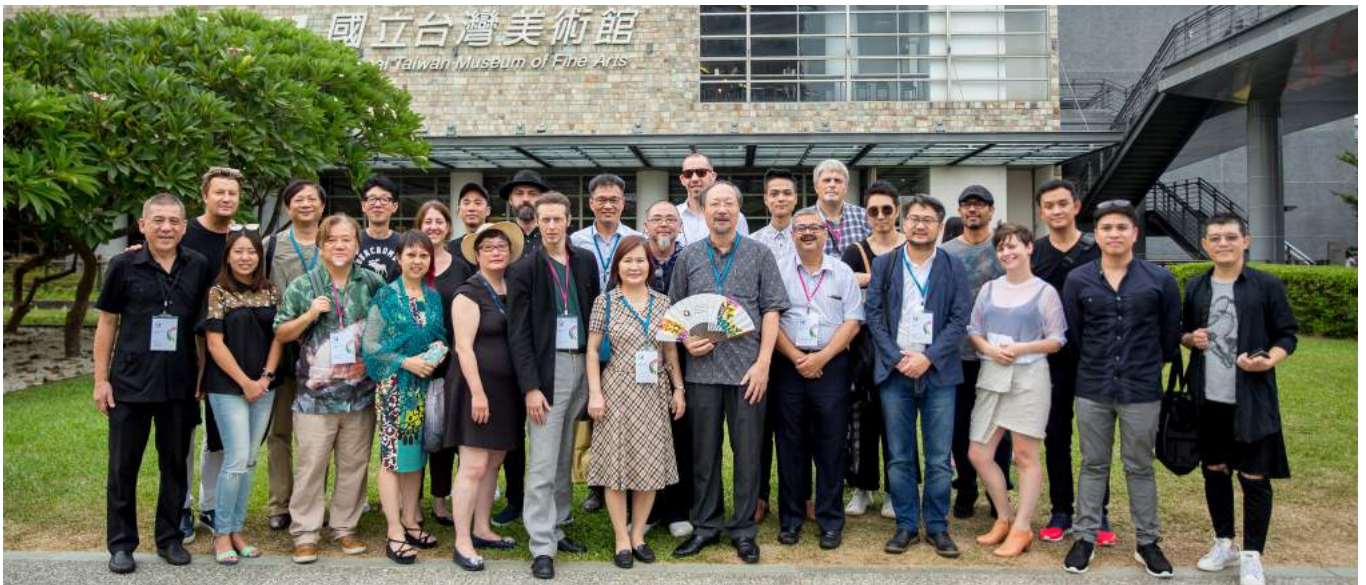

國際設計組織推派評審評語 Jury Comments from International Design Associations



法國設計師聯盟特別獎  
AFD Special Award



Arnault Garcia | 法國 France

評審講評 Jury Comments

此件作品以關懷環保為出發點，這主題是相當觸動人心的。由於臺灣是一座海島國家，因此對於臺灣人而言一旦大海被汙染了，將會面臨的是巨大的生態浩劫。隨著近年環保意識的抬頭，我個人非常樂見年輕世代的设计師能夠關心這方面的議題，並且利用這個機會來發展他們的創意，藉此吸引更多設計師來關懷環境保護的議題。

This work has environmental protection as its starting point, which is an appealing subject. Taiwan is an island nation, so once the ocean is polluted, Taiwanese people will face tremendous ecological crises in the future. In recent years, environmental awareness has been on the rise, and I am very glad to see that younger-generation designers pay attention to this issue. Through such an opportunity, they develop their creativity and use it to attract more designers to care about environmental concerns.



捷克布魯諾雙年展協會特別獎  
SBB Special Award



Pavel Noga | 捷克 Czech Republic

評審講評 Jury Comments

在評選時，視覺設計類的作品大部分以海報、視覺藝術相關的藝術節或機構為主題表現，別於一般的平面設計思考角度，此作品是以眼疾患者的視野為出發點，告訴人們這些患者於閱讀上及他們所看見的世界即是如此。作品除了表現獨特的設計風格外，且富含深遠的意涵，是此件作品的成功之處。

During the selection, it was found that in the Visual Design category, most entries were either posters or related to visual art festivals and institutions. This work, different from graphic design as usual, starts with the viewpoints of the visually impaired, telling people that this is what these patients see when they read and when they look at the world. In addition to its unique design style, this work also contains very rich and deep meanings, which is why it is a success.



新加坡設計行業總商會特別獎  
DBCS Green Design Award



Su Eing Chee | 新加坡 Singapore

評審講評 Jury Comments

這是一個在講述男孩與母親之間情感的動畫，我認為這部作品捕捉了許多美麗的細節和燈光以及漂亮、講究的剪接方式。動畫的最後，小孩終於感受到母親對他的愛，並且了解母親為孩子無私奉獻的精神是如此偉大，這是本部作品中最美好的時刻，由此道出在新加坡的老一輩經常會和下一輩人講述的道理：「尊敬長者，並感激他們的付出」。

This animation talks about the relationship between a boy and his mother. I think that this work captures many beautiful details, such as in its lighting, and the editing is quite delicate. At the end of the film, the child finally feels the love of his mother and understands that a mother's selfless and unconditional love towards her child is such a great thing. This is the best moment in this work, which brings out something that the elderly in Singapore often tell the younger generation: "Respect the elderly, and thank them for their efforts."

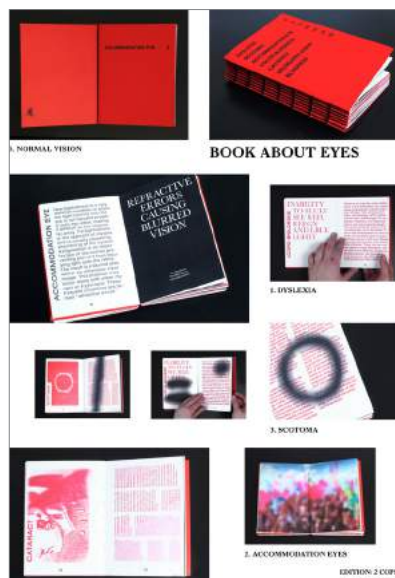



澳大利亞優秀設計協會特別獎  
GDA Design Innovation Award



**Brandon Gien** | 澳洲 Australia

#### 評審講評 Jury Comments

「小事」這項計畫可以說是真正的系統性設計，所因應的是一道非常值得解決的問題。「小事」計畫當中包含了一只設計精巧的矽杯「小事杯」，一個一應俱全、攜帶方便的包包「小事包」，以及一套整合的行動應用程式，能提供使用者準確、互動式的介面。這是整合式設計的絕佳範例，並且十分具有成功商業化的潛力。如果這項產品上市的話，未來將能為全球數百萬人帶來正面的效益。能看到如此高水平的設計思維應用在真實世界的問題上真的非常激勵人心。這道設計概念經過了完整的研究，並且以專業的方式進行呈現，因此獲得澳大利亞優秀設計協會特別獎的殊榮可謂實至名歸。

The RUKI Menstrual project is a true systems design approach that has been applied to a problem well worth solving. The Pack consists of a cleverly designed silicon cup, an all in one pack for easy travel and an integrated App that provides the user with an accurate and engaging interface. This is a brilliant example of integrated design and has every potential to be successfully commercialised. This product will have a positive impact on many millions of people around the world if brought to market. It is very encouraging to see this level of design thinking applied to a real world problem. The design concept has been thoroughly researched and professionally presented and is worthy of recognition at the highest level.



德國國家設計委員會特別獎  
GDC Special Award



**Janine Wunder** | 德國 Germany

#### 評審講評 Jury Comments

這件作品保留了拐杖的功能，同時減緩了以往拐杖的不舒適感，藉由有機木材的量身訂做，讓每位使用拐杖者都能擁有舒適且獨特的拐杖。另一方面，它的造型簡約時尚，並藉由設計的巧思，將兩支拐杖合併在一起，解決了傳統拐杖在放置牆面、桌面等會有滑落之不便的問題。

This work keeps the functions of crutches while reducing the uncomfortable feelings. It uses organic wood to customize the product so that every user can enjoy comfortable crutches that are unique to himself or herself. On the other hand, the look of the crutches is simple and stylish, and through some clever design, the two crutches can combine together, which resolves the problem of inconvenience that occurs when conventional crutches are put against the wall or on the table and tend to fall down.

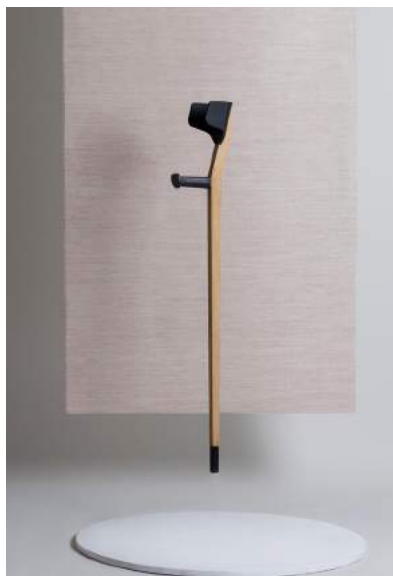



## 國際設計組織特別獎 International Design Association Special Prize

### 國際設計組織推派評審評語 Jury Comments from International Design Associations



香港設計總會特別獎  
HKDA Special Award



周思穎 **Beatrix Chow** | 香港 Hong Kong

#### 評審講評 Jury Comments

這件作品內容非常地有趣且機智是我選擇這件作品的原因。在影片開始的前一兩分鐘之內導演十分成功的塑造了角色們的性格，並讓觀眾進入情緒並且了解此作品的核心價值，在作品中每個人對於時間的觀念及想像皆不同，這讓我思考到動畫就該是如此。在看完動畫後，無論是生動的劇情或是畫面會深深烙印在觀者的心或腦海中，這就是為什麼設計或創作可以如此強而有力的改變人的主要原因。

I selected this work because its content is very interesting and smart. One or two minutes into the film, the director has already very successfully shaped the characters' personalities. The film invites the audience into its emotions and to understand its core values. In the story, everyone has different ideas and imagination about time, the realization of which reminds me that animations should be just like this. After watching an animation, the vivid story or imagery will be deeply imprinted in the audience's heart and mind. This is the main reason why design and creation can so powerfully make a difference in people.



國際設計社團協會特別獎  
ico-D Excellence Award



Zachary Haris Ong | 馬來西亞 Malaysia

#### 評審講評 Jury Comments

我所挑選的作品是著重於作品本身所呼籲的意涵，旨在環境保育以及對地球生態的友善維護，儘管這些都是不斷重複被帶出的議題，但影片仍以簡單且明瞭的方式提醒觀者，其實我們能夠做出更多的改變來保護生態。

When I did my selection, I focused on what this work is calling for, which is environmental protection and friendliness towards the global ecology. Despite the fact that these are issues that have been repeatedly discussed, this film reminds the audience in a simple and clear manner that we can actually do more to make a difference in environmental protection.



印度設計委員會特別獎  
IDC Special Award



Hridaysh Deshpande | 印度 India

#### 評審講評 Jury Comments

這是一個概念簡單的设计，將彈珠汽水的概念使用在點滴的瓶罐裡，就能防止血液逆流，這件作品設計巧妙之處在於設計概念形式相當簡單且產品易於使用，獲得印度設計委員會特別獎可說是實至名歸。

This is a piece of design with a simple concept. It applies the idea of marble soda to the infusion bottles as a way to prevent blood from flowing in the wrong direction. The clever design of this entry lies in the fact that its concept is quite simple while the product is easy to use. It absolutely deserves the Special Prize from the India Design Council.

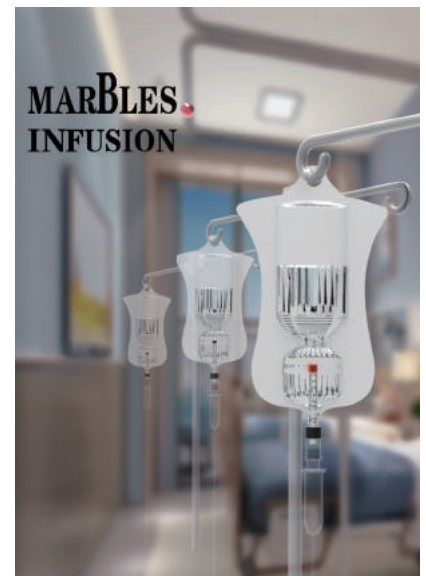
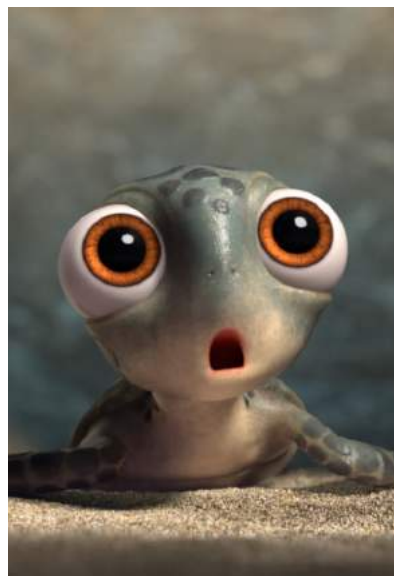



墨西哥國際海報雙年展協會特別獎  
IPBM Special Award



**Aram Huerta** | 墨西哥 Mexico

#### 評審講評 Jury Comments

我認為這件作品充分地將現代及傳統的元素用一種漂亮的手法連結在一起，因為文化是國家的根源，人們必須了解過去，才能創造未來。此作品具有吸引力的原因，是因為他以現代的表現手法傳達出傳統原住民文化，身為一位對文化層面有特別關注的設計師，我個人對於傳統文化是非常注重的，作品中使用原住民文化裡的符號與字形，除了圖像本身具有深遠的意義，也呈現了當代藝術之美，此件作品將文化意涵詮釋相當得宜，是件優秀之作。

I think this work fully combines modern and traditional elements in a beautiful manner. Culture is the root of a country, so people need to understand the past in order to create the future. This entry is attractive because it adopts a modern approach to expressing traditional indigenous culture. As a designer who pays special attention to cultural issues, I personally value traditional culture very much. In this work, the designers use symbols and characters from indigenous culture. Apart from their deeper meanings, such symbols and characters also embody the beauty of contemporary art. This entry has a good interpretation of cultural meanings, which makes it an outstanding piece of work.



日本設計振興會特別獎  
JDP Special Award



**青木史郎 Shiro Aoki** | 日本 Japan

#### 評審講評 Jury Comments

這件作品好的原因在於創作者非常仔細觀察問題在哪裡，然後試圖解決這項問題，在硬體方面，仍有許多細節需要修改和技術上的提升，以提高此件作品的完整度。但對我個人而言，以學生的角度出發，最重要的是學生在面對一項課題的時候，該如何去正視、觀察，並且能夠坦率地試圖去解決，這是對於每位學生來說是最重要的部分，而學生的觀察力是非常豐富，他們試圖觀察並找出問題所在而提出改善，這觀點是我認為是非常優秀的。

This work is good because the designer very carefully observes where the problem is and then tries to solve the problem. In terms of the hardware, there are many details that still need to be refined and improved technically so that the overall completeness of this product can be enhanced. However, I personally believe that from the perspectives of a student, the most important thing while faced with an issue is how to take it seriously, observe it, and then attempt to resolve it in an honest way. For every student, this is the crucial part. Students have very rich observations, and I think it is excellent that they try to observe, identify the problem, and then put forward a solution of improvement.



國際設計組織推派評審評語 Jury Comments from International Design Associations



韓國現代設計協會特別獎  
KECD Special Award



**Bang Won Lee** | 韓國 Korea

評審講評 Jury Comments

自從手機出現以來，世界已經開始用一部手機來完成各種事情。它已成為享受電話，短信，上網，玩遊戲，觀看視頻，查看和創建文檔等休閒活動的重要手段。這個作品通過新穎的思想和自己的原創方式，並按照“機遇”之主題來表達智能手機的功能與社會關聯性之意涵的作品。

Since the advent of mobile phones, the world has been increasingly able to accomplish all sorts of tasks on one single phone. The mobile phone has become an important channel for people to make phone calls, send messages, browse the Internet, play games, watch videos, check and create documents and files, etc. This piece of work expresses novel ideas in an original way, and it follows the theme, "Opportunity", to explore the meanings in the relationship between mobile phone functions and the society.



澳門設計師協會特別獎  
MDA Special Award



**劉華智 Mann Lao** | 澳門 Macau

評審講評 Jury Comments

我之所以會選擇這部作品，是因為我認為動畫是可以透過媒體讓創作者能大膽地表達出內心的想法，作者透過動畫傳達有關男女平等的議題，而這部作品表現一個創作者和觀者之間的關係，除了天馬行空的思維之外，也著重帶給觀者的深刻的感受。本部作品傳達了男女平等的議題，更帶出了創作者和觀者之間的關係，作品本身的風格和畫面並不是非常特別，但創作者透過簡單的技法結合創新的想法，讓整部影片更加豐富有趣。

I selected this work because I believe that animation is a medium for the creators to be bold in expressing their inner thoughts. Through this animation, the designers address the issue of gender equality and explore the relationship between the designers and the audience. Apart from its wild imagination, the film aims to provide the watchers with deep feelings, too. This work conveys the idea of gender equality and highlights the relationship between the designers and the audience. The style and imagery themselves may not be very unique, but the designers use simple techniques combined with innovative ideas, making the whole animation richer and more interesting.



泰國創意設計中心特別獎  
TCDC Special Award



**Nat Yoswatananont** | 泰國 Thailand

評審講評 Jury Comments

一開始看到這部作品時，就被其美術設計及故事的元素所深受吸引，包含創作者使用「海」及來自燈塔的「光」來描述時光的逝去、從小到老所經歷的種種事情，劇情走向與音樂做了完美的結合。此部作品不僅故事劇情完善，同時也帶給觀者更深一層的想法與概念。

When I first watched this animation, I was deeply attracted by its art design and the elements of its story. The designer uses the "sea" and the "light" of the lighthouse to depict the passing of time and everything that has been experienced from childhood to old age, and the music perfectly integrates with the plot. This piece of work not only has a complete storyline but also brings to the audience a deeper level of thinking and concepts.

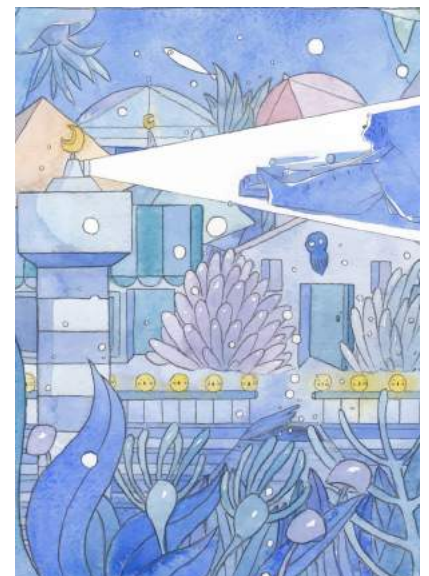



## tDA Asia

the Design Alliance Asia

亞洲設計聯盟特別獎  
tDA Asia Special Award



高少康 **Hong Ko** | 香港 Hong Kong

### 評審講評 Jury Comments

這是一部個性非常強烈的作品，故事碰觸了宗教、成長與性的壓抑等議題，探討的內容並不受一般大眾所喜愛，是一部具敏感話題的作品。這部作品一開頭的劇情走向就令我非常想繼續看下去，動畫的內容給了觀者相當多的驚喜，其藝術表達的手法具有強烈個人特色，作為評審，我個人是非常鼓勵類似的作品持續能持續創作、出現。

This is an animation with a very strong personality. Its story involves issues such as religion, growing up and sexual suppression, all of which are not subjects to be liked by the general public, so this is truly a sensitive piece of work. At the very beginning, the story already makes me want to keep watching, and the content provides the audience with quite a few surprises all along. Besides, the techniques of artistic expression have a very strong and unique personal style. As a juror, I very much encourage more works like this to be created in the future.



台灣創意設計中心最具商品化潛力獎  
TDC Greatest Market Potential Award



孫善蓉 **Steffy Sun** | 臺灣 Taiwan

### 評審講評 Jury Comments

這件作品用到的元素跟巧思非常地單純，沒有多餘的設計，是件聰明且簡單的產品，而整體的設計概念也相當符合本次主題「Opportunity」。另外以台灣創意中心頒發的獎項屬性來說，基本上會選擇公益性質和關懷社會的作品，除了可以協助一些弱勢團體，同時也是呼籲整個設計產業在做設計的時候能以需要幫助的族群為出發點，而並非一味的創造消費型的產品。設計的本意是讓設計者利用設計去創造更好的世界，而這些弱勢族群也是我們的一份子，能讓這些人的生活提升品質，打造一個充滿愛跟關懷的環境，我認為是設計師的職責所在。

The elements and concepts used in this work are very simple, without any redundant design. It is a smart and simple product, and the entire design concept very much corresponds to the theme this time: "Opportunity." In addition, Taiwan Design Center usually awards entries with elements of public welfare and social care. Doing so can lend support to groups of the disadvantaged, and it is also a way to urge the entire design sector to design for those who are in need, rather than endlessly create consumption-oriented products. Designers are meant to use design to create a better world, and these disadvantaged individuals are part of us. I believe that it is our responsibility as designers to enhance their quality of life and establish an environment full of love and care.



紐西蘭設計師協會特別獎  
DINZ Best Design Special Award



Mike Howie | 紐西蘭 New Zealand

### 評審講評 Jury Comments

從一開始，這部作品就相當出眾。影片使用了強而有力的象徵、有限的顏色以及巧妙的2D動畫轉場，影片的視覺表現經過了巧妙、精良的編排，呈現的是一位自閉症患者透過雙眼所看到的世界。作品呈現出的世界既熟悉又陌生，而我們也看到了主角辛苦地理解這個我們視為理所當然的世界。這部動畫具有詼諧的本質，並且大膽使用了有機的象徵符號、動畫與情感豐富的音樂，這些都使得這部作品緊密切合了主題。

From the start, this piece stood out with its strong use of symbolism, limited palette and clever use of 2D animated transitions. A clever, nicely constructed visual representation of the world seen through the eyes of someone living with Autism. It presented a world both familiar and foreign, in which we see our character struggling to make sense of world most take for granted. Its whimsical nature along with its explorative use of organic symbolism, animation and emotive music lent itself nicely to its subject.





法國設計師聯盟特別獎  
AFD Special Award

### Pick and Throw

作者姓名 Name of Designer(s)

王尹伶

Yin-Ling Wang

指導老師 Instructor(s)

林俊良、施令紅

Chun-Liang Lin, Ling-Hung Shih

學校所在地 Location of School

臺灣

Taiwan

學校名稱 Name of School

國立臺灣師範大學

National Taiwan Normal University



#### 作品說明 Project Description

本海報試圖傳達停止食用魚翅和海洋生物污染，導致寄居蟹沒有貝殼可居住的資訊，呼籲給他們一個生存的機會。近年來，因漁業發達，卻也因過度捕撈，對海洋生態產生危害，魚類資源已逼近枯竭，生態鏈近乎斷裂。作品中手掌拓印隱喻著如污染繼續下去，未來將會傷害到我們。

The poster tries to convey the message that stop shark fin and marine life pollution. Because of the world's overfishing, marine species are facing severe threat and endangered. The food chain is utterly damaged. The handprints in the artwork symbolizes the marine life pollution will hurt us in the future.





捷克布魯諾雙年展協會特別獎  
SBB Special Award

### Book about Eyes

作者姓名 Name of Designer(s)  
Anna Dmitrieva

指導老師 Instructor(s)  
Stefan Lashko, Ivan Yakushev

學校所在地 Location of School  
俄羅斯  
Russia

學校名稱 Name of School  
國立高等經濟大學—藝術與設計學院  
HSE Art and Design School



### 作品說明 Project Description

眼睛是人類身體最重要的器官之一，然而不幸的是，有許多人罹患了各式各樣的眼睛疾病。我決定試著去想像：究竟視覺上有困難的人們是如何去感知、如何「看」待這個世界呢？我將這本書分成了八個章節，每個章節分別探討一種最常見的眼睛疾病：0. 疾病相關資訊（只有這一部份沒有圖像效果）1. 失讀症 2. 盲點 3. 眼調節 4. 色盲 5. 白內障 6. 視力下降 7. 失明

An eye is one of the most important organ of the human body. Unfortunately, there are many people who suffer from various eye diseases. I decided to give it a try and imagine how visually challenged people perceive or "see" our world. I divided the book into 8 chapters dedicated to the most common eye diseases: 0. Information on diseases (only this part without graphical effects). 1. Dyslexia 2. Scotoma 3. Accommodation eyes 4. Color blindness 5. Cataract 6. Decreased vision 7. Blindness





新加坡設計行業總商會特別獎  
DBCS Green Design Award

## The Dumb Elephant

作者姓名 Name of Designer(s)  
Farhana Hossain

指導老師 Instructor(s)  
Hsiang-Chin Moe

學校所在地 Location of School  
美國  
United States of America

學校名稱 Name of School  
紐約視覺藝術學院  
School of Visual Arts



### 作品說明 Project Description

「啞巴象」(The Dumb Elephant · 2017) 是一部 2D 動畫影片，探討一對母子之間從爭執到和解的旅程。故事中沒有父親的角色，而兒子大衛 (Dave) 正處於母子彼此都難以理解對方的年紀。這部影片利用非線性的時間軸和鉅細靡遺的場景建構，所希望傳達的理念是：當親子缺乏溝通時，雙方就會開始產生距離，而彼此之間彷彿就像是佔據了一隻無聲的大象一樣。

The Dumb Elephant (2017) is a 2D animated film that explores the journey of discord and reconciliation between a mother and her son, Dave. With no father figure, Dave is at an age where both mother and son find it difficult to relate to each other. Using a non-linear timeline and meticulously constructed sets, the film hopes to shed light on instances when the lack of communication between parents and kids creates distance and occupies space in their relationship like an elephant in the room.



## 小事杯 RUKI menstrual cup



### 杯口

杯口窄，杯身寬的形狀能縮短，放入時杯口緊貼子宮頸內，能避免女性因流血造成血塊的積聚，再藉由杯身收緊，能將經血吸納於杯內，進而縮短經期。

The shape of narrow opening and wide body is capable of inserting it with the smaller head after folding. It set on the capacity according to Asian girls' average menstrual flow. And we decrease the capacity slightly to reduce feel by its inserting.

### 杯口

杯口內加一層半口長材料，杯口外設置橡皮圈於沖洗中推出小口內縮。

Added from the general cup, the inner opening is more capable of holding it all off the smallest hole.



### 杯身

杯身加窄底部與杯口設計，避免經血積聚於杯底，因杯口與杯身設計，杯身加窄底部與杯口設計，避免經血積聚於杯底。

To fit with narrow folding easily. The narrow thickness design, making the folding part thinner and thickening the bottom, which increases the cup shape.

### 杯身

杯身加窄底部與杯口設計，避免經血積聚於杯底，因杯口與杯身設計，杯身加窄底部與杯口設計，避免經血積聚於杯底。

To reduce the difficulty of taking out the cup. The new lab design allow girls to pull out the cup by using only one finger. And the one-piece design stabilize the rim to avoid the cup moving while taking it out.

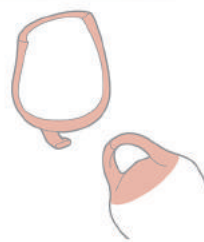

## 小事清洗包 RUKI Pack



臺灣目前多數公共廁所均不設置洗手間，早期廁所的空間狹小，沖水有獨立洗手台等設施，在外國旅行時容易造成女性打掃困難。RUKI清洗包能解決女性沖洗的問題，其設計，能避免廁所中衛生紙或衛生紙造成衛生問題；並利用加蓋的沖水設計，可避免女性產生臭味，避免女性沖洗時產生臭味，可避免女性產生臭味。

Most of the public restrooms are not constructed in Taiwan. The space is the single stall is too small, and without a sink to do. There are the problems of girls whenever travel or even the menstrual cup hygiene. RUKI Pack can overcome the environmental inconvenience by having the equipment of water, feminine wipes, and tissue and the bag are designed to fit the clothes which allow girls to empty their hands.

杯身上的顏色標有婦女安全衛生沖洗的說明，幫助女性沖洗更安心，且更方便利用APP控制。

The standard-colored label on bottle's water can assist users to feel their blood color whether normal or not before the inserting, and simply use second via app.



## 小事紀錄 RUKI App



### A. 紀錄 RECORD

記錄、溫度、經期日期、心電、生理期、體重、血氧、壓力、運動量、睡眠時間、生理期、體重、血氧、壓力、運動量、睡眠時間。

Recorded information contains blood, water, with or without blood, etc., mood, physiological conditions, weight changes, food intake, etc.

### B. 個人 USER INFORMATION

記錄個人資訊將被儲存於雲端，可避免資料遺失或洩露。

Recorded information will be saved and organized, while it can be used as data for the needs of medicine.

### C. 提醒 NOTIFICATION

自動計算並提醒下次生理期的時間，下次生理期的日期、提醒、安全期等資訊。

The app will predict and remind girls the menstrual day, changing phase, time of the next period, Duration, etc.

### E. 加密 IDENTIFICATION

密碼驗證 指紋驗證登入

Password verification Fingerprint recognition

### D. 交流 FORUM

提供有用資訊，讓女性可以互相學習、分享，可以更新、討論、安全期等資訊。

All users can do discussions, sharing and discussing, it's made them much easier to figure out the outdated knowledge all the menstrual period information.



澳大利亞優秀設計協會特別獎  
GDA Design Innovation Award

## 小事 RUKI

作者姓名 Name of Designer(s)  
林璋群、章芸甄  
Wei-Chun Lin, Yun-Jen Jang

指導老師 Instructor(s)  
葉文凱  
Wen-Kai Yeh

學校所在地 Location of School  
臺灣  
Taiwan

學校名稱 Name of School  
東海大學  
Tunghai University



## 作品說明 Project Description

RUKI 小事是一個專為亞洲女性設計的生理用品系統，包含月亮杯、外出清潔組和紀錄 APP。由於現有產品、中華文化保守和公廁環境不友善等因素，導致許多女生無法自在地選擇和舒適地度過生理期，因此，我們藉由設計尺寸、用量都符合亞洲女生使用狀態的月亮杯，協助女生們踏出使用的第一步；而清潔組可適應任何公共廁所的環境，女生可以放心在外更換；紀錄 APP 則可讓每個週期身體的狀況數據化，女生可以精確地瞭解自己，更可以作為往後醫療診斷時的依據。

RUKI is a feminine caring system specially designed for females in Taiwan. By getting to know Asian women's doubts towards periods, menstrual products and menstrual cups, we could resolve all of them in sequence. The RUKI feminine caring system is categorized into the menstrual cup, cleaning pack and application, and each part will be expected to effectively assist all users in their doubts.





德國國家設計委員會特別獎  
GDC Special Award

## Wooden Crutches

作者姓名 Name of Designer(s)  
Aleksandra Žeromska

指導老師 Instructor(s)  
Daniel Zieliński

學校所在地 Location of School  
瑞士  
Switzerland

學校名稱 Name of School  
洛桑藝術學院  
Ecole cantonale d'art de Lausanne (ECAL)



### 作品說明 Project Description

這項計畫的目標在於，設計出優雅而量身打造的拐杖，並且將重大的人體工學問題予以排除。這些拐杖完全能依據使用者的身形、比例加以客製化。木頭材質的測量與裁切能確保拐杖合每個人的身，同時能夠妥善運作。拐杖的前臂與握把非常容易更換，並且有三種不同的尺寸—小、中、大。在計畫開始之前，我們歷經了十分完整的研究階段，其中包含了人體工學的研究。

The aim of this project was to design an elegant, made to measure crutches, which eliminate the major ergonomic problems. The crutches are fully customizable according to body size and proportions. The wood is measured and cut to ensure it fits and functions properly for each individual. Forearm and handle, which are very easily replaceable, are made in 3 different sizes - S, M, L. The project was preceded by a very thorough research phase including an ergonomic study.

### WOODEN CRUTCHES

personal project

Disability is still a taboo in our society, also in the world of design. People with disabilities are often forced to use objects that impact their well being by perpetuate and reinforce these harmful attitudes. As a result, a barrier arises between people with disabilities and that of those without. The aim of this project was to create an elegant object that instills confidence. In today's world, wood is an unusual material to use in this form. Apart from the inherent aesthetic qualities and strength of the material, wood surprisingly made the object lighter in weight as well.

The crutches are fully customisable according to body size and proportions. The wood is measured and cut to ensure it fits and functions properly for each individual. Forearm and handle, which are very easily replaceable, are made in 3 different sizes - S, M, L. The project was preceded by a very thorough research phase including an ergonomic study.

Designer project, Author: Aleksandra Žeromska, Academy of Fine Arts, Warsaw, graphic: Kęstusius Dudauskas, design: Aleksandra Žeromska

### The main project characteristics:

Advantages over existing solutions:

1. Product eliminates the major ergonomic problems thanks to: correct hand positioning on the handle - crutches are shortened to measure, which makes them more stable, and perfectly adjusted to individual user's body.
2. Crutches are fully customised, which is necessary to keep good and healthy body posture, especially for long periods of consciousness. Forearm and forearm are replaceable, available in 3 sizes - S, M, L.
3. New design quality, which fills the huge market gap for an elegant, good looking crutches. Today's solutions are designed in a "spotty" aesthetically way which isn't a solution that suits everybody.
4. Durability - crutches can be used for a long time, so buying them supports conscious consumption.
5. The convenience of putting off crutches. With a unique ribbed in the range of the handle, the crutches can be leaned and rested against a wall or a table. They do not slide down.

DIMENSIONS		S	M	L
Hand width:		82 - 90 mm	92 - 100 mm	100 - 108 mm
Forearm length:		20 - 24 cm	24 - 28 cm	28 - 32 cm



香港設計總會特別獎  
FHKDA Special Award

## KCLOC

作者姓名 Name of Designer(s)  
Ninaad Kulkarni

指導老師 Instructor(s)  
Terrence Masson

學校所在地 Location of School  
美國  
United States of America

學校名稱 Name of School  
紐約視覺藝術學院  
School of Visual Arts



作品說明 Project Description

這是一部關於時間的3D動畫紀錄片。  
3D animated documentary about time.







國際設計社團協會特別獎  
ico-D Excellence Award

## Verge

作者姓名 Name of Designer(s)  
Ching-Tien Chu

指導老師 Instructor(s)  
Hsiang-Chin Moe, Terrence Masson,  
Trilby Schreiber, Michael Tanzillo

學校所在地 Location of School  
美國  
United States of America

學校名稱 Name of School  
紐約視覺藝術學院  
School of Visual Arts



作品說明 Project Description

這是一部關於海龜寶寶的 3D 動畫。  
3D animation about baby sea turtle.





印度設計委員會特別獎  
IDC Special Award

彈珠輸液袋  
Marble Infusion Bag

作者姓名 Name of Designer(s)  
何靜

Jing He

指導老師 Instructor(s)

龐月

Yue Pang

學校所在地 Location of School

中國大陸

China

學校名稱 Name of School

天津理工大學

Tianjin University of Technology



作品說明 Project Description

「彈珠」輸液袋是一種新型輸液袋，為防止打完點滴之後忘記關開造成的血液回流與人體內進入空氣，從而減輕醫護人員的負擔。其靈感來源於日本彈珠汽水，通過彈珠的漂浮與墜落最終控制水的流度。

Marble infusion bag is a new kind of infusion bag, to prevent forget to switch off after finished intravenous drip of blood flowing and into the air in the human body, so as to reduce the burden of health care workers. Its inspiration from Japanese pinball soda, through the marbles floating and falling finally control the flow of water. Using soda principle applied to the marble, marble with easy floating material, with a flying attitude on appearance give a person the sense with ease.



MARBLES  
INFUSION

Hummization Amusing

"Marble" infusion bag is a new type of infusion bag. In order to prevent the intravenous drip, there is no timely shutdown of the blood backflow and air into the body. It was inspired by apanese marbles and controlled the flow of water through the floating and falling of marbles. The marbles and applied to the tumbler principle, low gravity, high density, can be in the water floating, absolute stability. And the appearance of different words, design is in the visual effect, so that in the hospital depressed environment, people feel happy and relaxed.

Problem analysis situation

- BOREDOM BORING
- CONSIDER BUSYNESS
- CHECK TIMELY

**Before**

After the intravenous drip has not been done, the infusion valve has been closed in time. It is easy to cause the blood to flow back or air into the body, causing more serious diseases.

**After**

Marbles can flow with the liquid, when there is no liquid, marbles will plug the hole, will not cause

**FUNCTION**

Water drips more with the flow of liquid.

**Characteristic**

A small rubber trap is connected with the opening of the infusion bag, and holes are arranged around the small tube, so that the small ball can move.

Tumbler + Plastic =

The use of the ball tumbler principle, the liquid density and to achieve floating and falling.





墨西哥國際海報雙年展協會特別獎  
IPBM Special Award

**米好! Malahok**  
**Millet Malahok**

作者姓名 Name of Designer(s)  
黃天韻、王穎婷、黃心如、曾子容、  
張巧妍、羅詩雅  
Tien-Yun Huang, Ying-Ting Wang,  
Hsin-Ju Huang, Zih-Rong Zeng,  
Chiao-Yen Chang, Shi-Ya Luo

指導老師 Instructor(s)  
涂以仁  
Izen Tu

學校所在地 Location of School  
臺灣  
Taiwan

學校名稱 Name of School  
國立臺中科技大學  
National Taichung University of Science  
and Technology



作品說明 Project Description

小米是上天賜予原住民的共通精神食糧。我們賦予臺灣原住民小米文化，設計系列伴手禮。小米罐外包裝從不同角度擷取 16 族的識別圖騰。如：達悟族拼板舟，拉阿魯哇族的聖貝祭，編織縫紉表達原民手作，內包裝則是民族服飾色彩象徵。小米餅乾透過線形描繪來傳遞原住民的生活樣貌。小米巧克力擷取了六族與小米有關的傳說，並透過明信片形式傳達。小米蛋糕透過原住民的紅、白、黑三個共同識別色，加上文字族語，用羅馬拼音學習到原住民語言。米好! Malahok 透過文化設計將原住民識別傳達至全世界。

Millet is the God-given mutual food of Taiwanese indigenous peoples. We put their culture in and design series of souvenirs. To emphasize the differences between them, we use threads to sew out their culture part; take simple lines to present daily life; select 6 millet-relating legends and present in postcard form; use 3 mutual identification colors with Roman alphabets to convey their spoken words. Through cultural design, Millet Malahok makes Taiwanese indigenous peoples be identified worldwide.

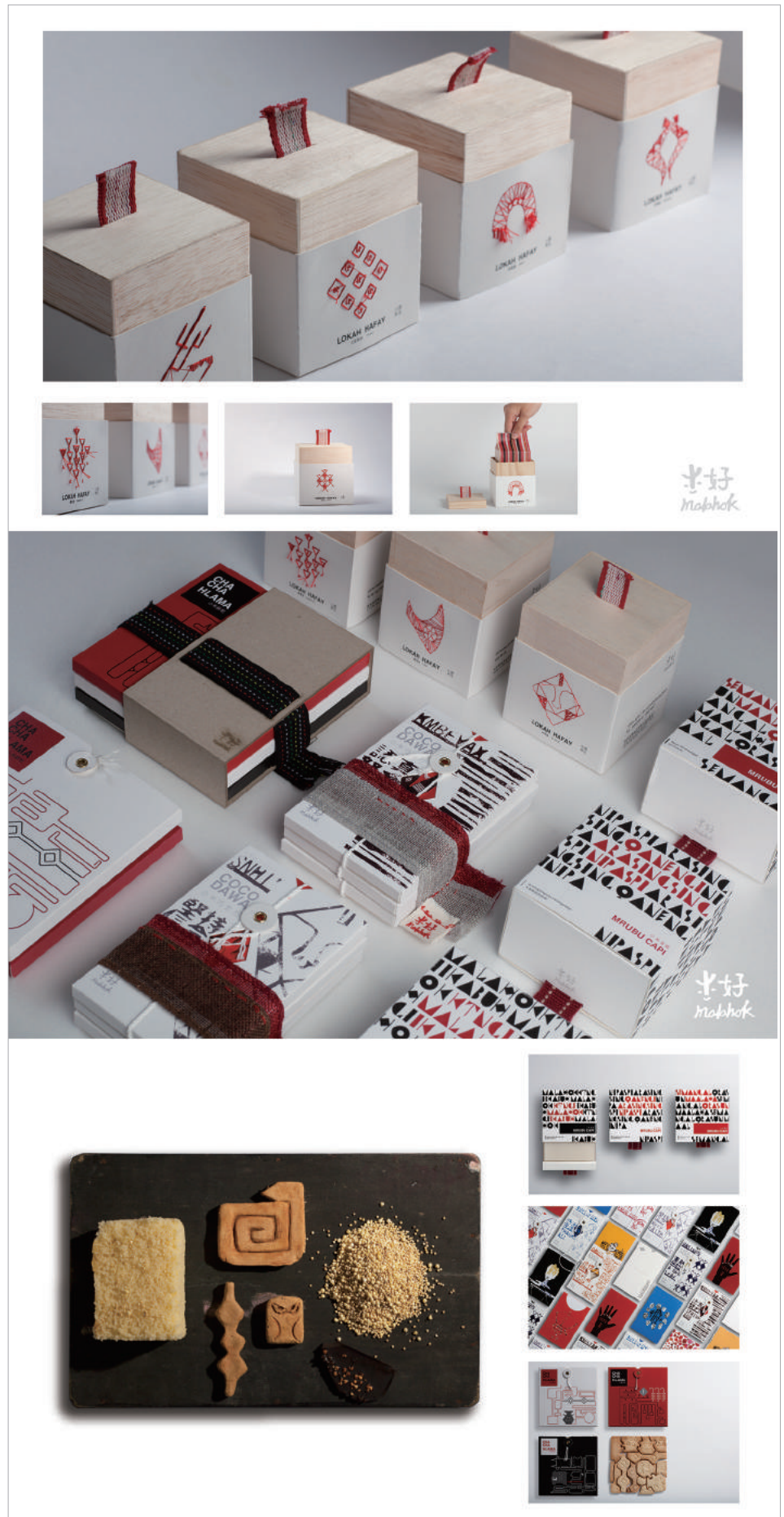



日本設計振興會特別獎  
JDP Special Award

### Maattam-Retrofit Patient Transfer System

作者姓名 Name of Designer(s)  
**Asish Mohandas**

指導老師 Instructor(s)  
**Nachiketa Tiwari**

學校所在地 Location of School  
**印度  
India**

學校名稱 Name of School  
**印度理工學院 (坎普爾)  
Indian Institute of Technology, Kanpur**



#### 作品說明 Project Description

採用彈珠汽水原理運用於此，彈珠採用易漂浮的材質，外形上以一種飛翔的姿態給人以輕鬆的感覺，而這正是醫院所缺少的東西，讓患者不會那麼壓抑與緊張。

Maattam is a retrofit system for transferring patients between different rest units such as a bed or an operating table. It eliminates occurrence of secondary injuries for the patients, and reduces manual labor for the workers involved, during patient transfer. The existing mechanisms either slide, roll or drag the patient for transferring, inducing lot of jerk and pain. But in maattam, the patient is transferred safely without causing any sort of discomfort.



**the exploded view**

**A Retrofit Mechanism**  
Maattam, Maattam transfer mechanism being fixed on to a standard wheeled stretcher with a flat top base and height adjustment facility.

**Maattam + Wheeled Stretcher trolley = Patient transfer stretcher**

**How it Works ?**

The mechanism works on the principle of a standard bearing or sliding mechanism with a water container (ball) and rollers on either side. These rollers are fixed to the side rails of the stretcher. The bearing is connected to a roller which is attached to the patient's body. The bearing is connected to a roller which is attached to the patient's body. The bearing is connected to a roller which is attached to the patient's body.

1. The roller is placed on the rollers.
2. The patient is placed on the stretcher.
3. The roller is pushed down by the patient's weight.
4. The patient is transferred safely.

**1:2 Scale Prototype & Usability Testing**





韓國現代設計協會特別獎  
KECD Special Award

是開放還是限制？

**OPEN or RESTRICT?**

作者姓名 Name of Designer(s)

盧宏文

Hong-Wun Lu

指導老師 Instructor(s)

曹融

Jung Tsao

學校所在地 Location of School

臺灣

Taiwan

學校名稱 Name of School

國立雲林科技大學

National Yunlin University of Science  
and Technology



作品說明 Project Description

手機的進步是帶來更開闊的視野，還是繼續封閉自我於框架中？

Does the advance of cell phones brings wider horizon, or keep sealing ourselves in our own frames?



# MDA

澳門設計師協會特別獎  
MDA Special Award

## Retouch

作者姓名 Name of Designer(s)

許雅媛、王意嫻、林郁儒、李怡軒、黃筱涵

Ya-Yuan Hsu, Yi-Shan Wang, Yu-Ru Lin, Yi-Hsuan Lee, Xiao-Han Huang

指導老師 Instructor(s)

馮偉中

Wei-Jung Feng

學校所在地 Location of School

臺灣

Taiwan

學校名稱 Name of School

朝陽科技大學

Chaoyang University of Technology



作品說明 Project Description

在大眾對於「美」越趨狹隘、單一化的定義下，女性面對外界一連串的改革與規範又該如何自處，當中的對立、拉扯及衝突不斷。透過象徵社會大眾的畫師與象徵自然女性的畫中人之間的對決，帶出我們所想提出的疑問：逐漸單一化的審美觀，真的是我們在這樣多元的社會中所應追求終極目標的嗎？

As definitions of beauty become ever more exacting, the standard of beauty are becoming more and more homogenous.

Seems like people being less and less appreciate for the individual differences, it makes us wonder: "In the plural society we lived in nowadays, is this the value of beauty we try to pursue?"

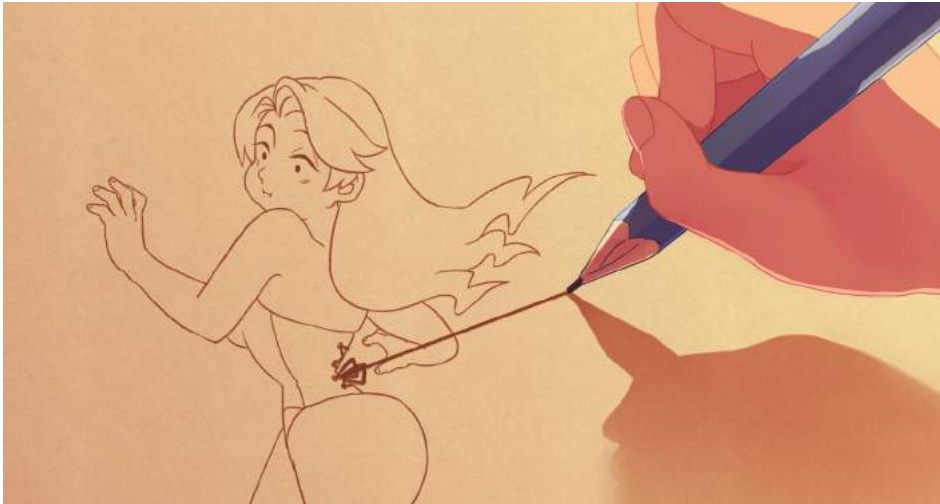





泰國創意設計中心特別獎  
TCDC Special Award

## 燈塔

### The Lighthouse

作者姓名 Name of Designer(s)

康超

Chao Kang

指導老師 Instructor(s)

黃曉瑜

Xiao-Yu Huang

學校所在地 Location of School

中國大陸

China

學校名稱 Name of School

福州大學廈門工藝美術學院

Xiamen Academy of Arts and Design,

Fuzhou University



#### 作品說明 Project Description

我的動畫是由自己創作的同名繪本改編的，動畫構圖保留繪本風格的方式，講述了一個關於追逐的故事。他，年少時，憧憬大海，嚮往遠行。年中時，披星戴月，追逐大海。年老時，踏上歸途，尋覓故鄉。直至一場暴風雨來臨，海浪吞沒了船隻，吞沒了一切，當他緩緩沉向海底，燈塔的光似乎再次閃爍，透過燈塔的光，他又看到了朝思暮想的家鄉和那個奔向大海的少年……故事以海喻夢想，主角照應我們每一個人，人的一生有太多機會，抓住機遇，也是在不斷追逐夢想。

My animation is adapted from my own picture book of the same name. The animation composition retains the style of the picture book. It tells a story about the pursuit.

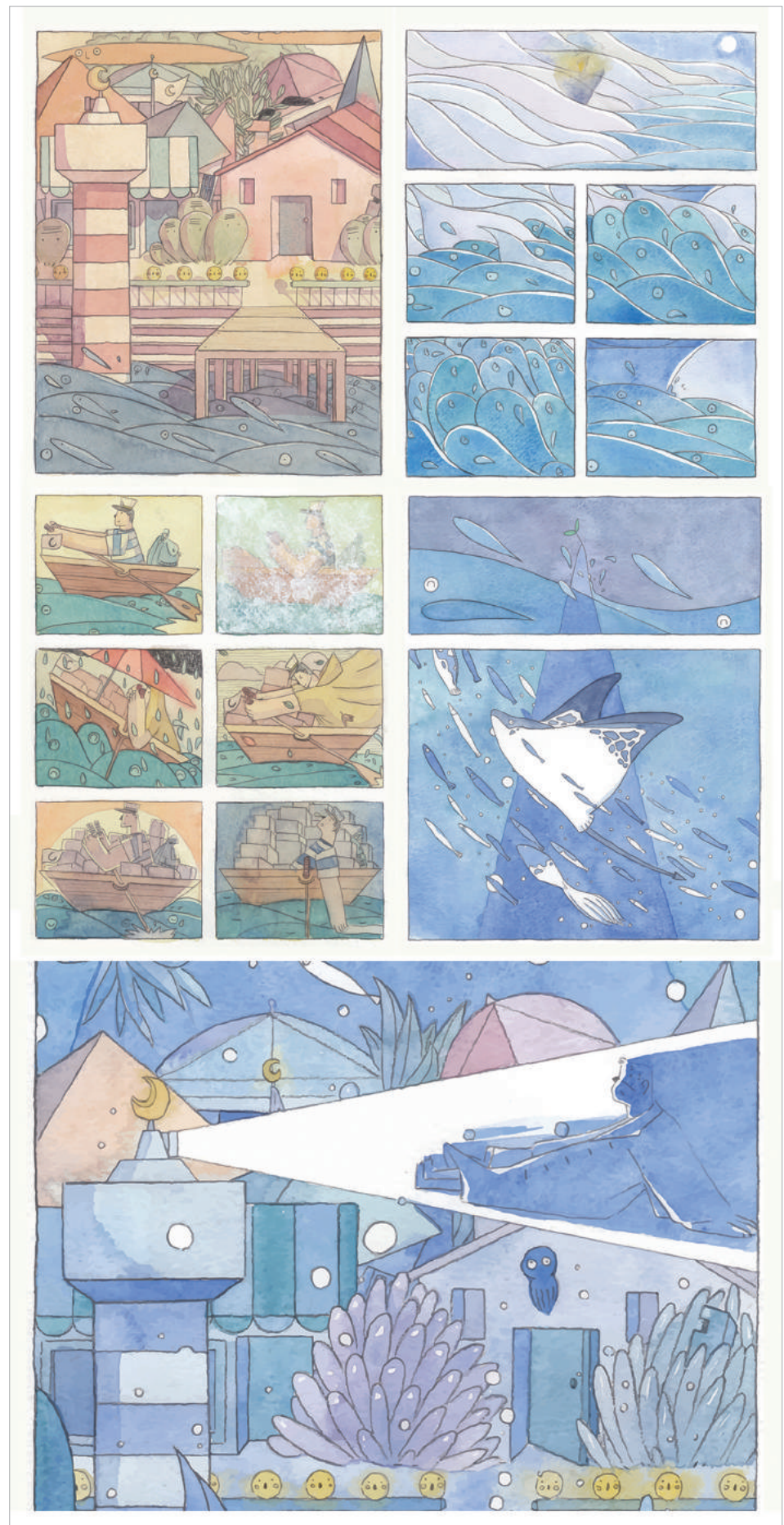



## tDA Asia

the Design Alliance Asia

亞洲設計連特別獎  
tDA Asia Special Award

### 基石

#### Fundamental

作者姓名 Name of Designer(s)

邱士杰、張明潔、林孝親、林思好  
Shih-Chieh Chiu, Ming-Chieh Chang,  
Hsiao-Chin Lin, Szu-Yu Lin

指導老師 Instructor(s)

鐘世凱  
Shih-Kai Chung

學校所在地 Location of School

臺灣  
Taiwan

學校名稱 Name of School

國立臺灣藝術大學  
National Taiwan University of Arts



#### 作品說明 Project Description

本動畫發想自個人實際經歷，旨在探討僵化的宗教信仰對青少年所造成的傷害，青少年在成長過程中受到宗教的壓迫，內心的掙扎是旁人所無法理解的，因此我藉由符號及象徵性的隱喻、諷刺手法，描述保守教會造成的心理傷害，和青少年主角在面對逼迫下的痛苦與抉擇，藉以觀眾能了解其心境，並鼓勵同樣經歷的人們勇於克服心理困難。

The animation is based on a self-experience. It is about the injury of rigid religious upbringing to children. By using metaphors of signs and symbols, the animation highlights and describes the mental illness caused by the conservative church on the lead character and illustrates how the character makes his way out from his dire situation.

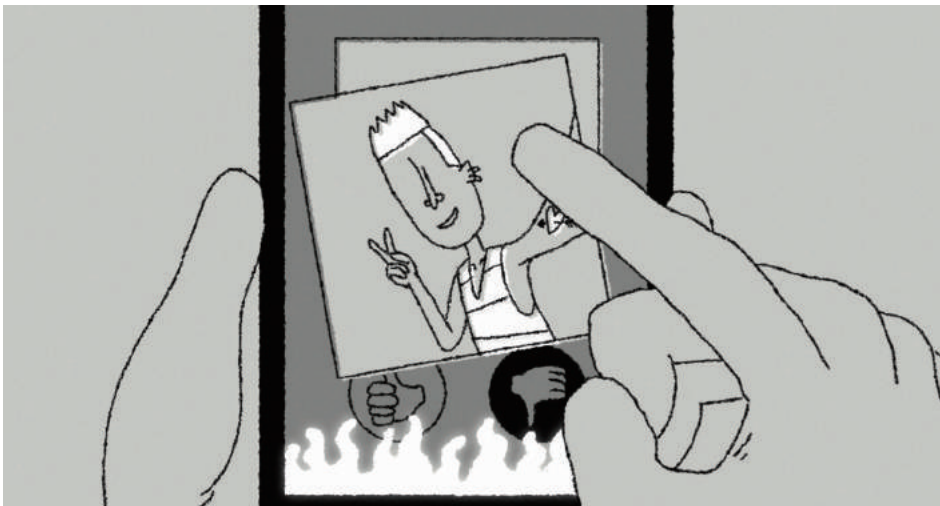
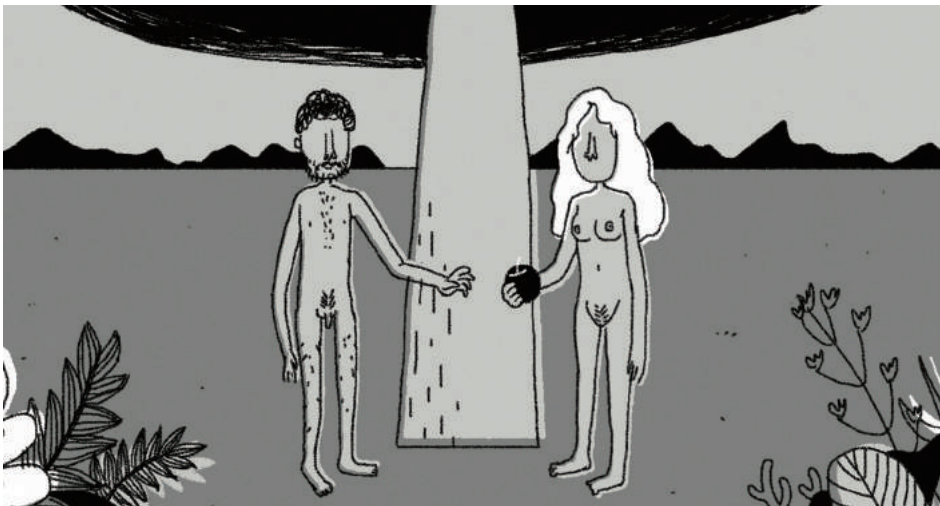
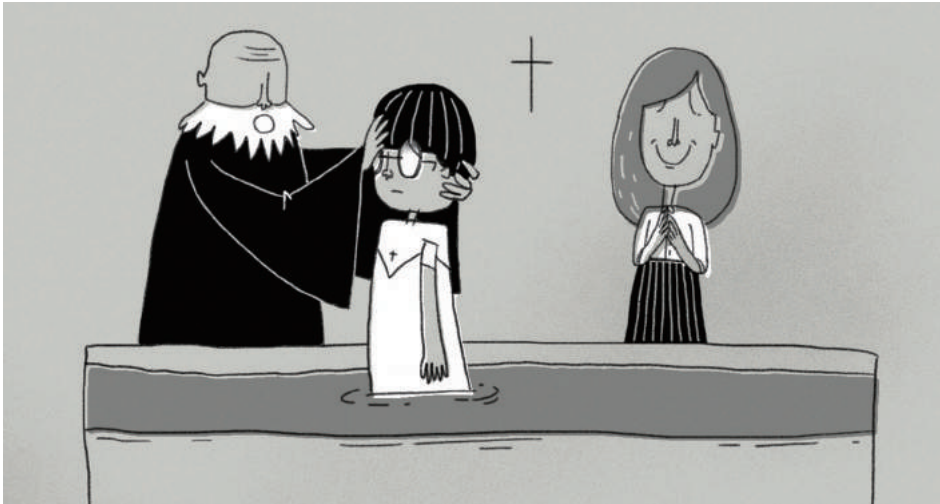





台灣創意設計中心最具商品化潛力獎  
TDC Greatest Market Potential Award

### Eatsy

作者姓名 Name of Designer(s)

Jexter Lim Sen Ye

指導老師 Instructor(s)

Song Kee Hong

學校所在地 Location of School

新加坡

Singapore

學校名稱 Name of School

新加坡國立大學

National University of Singapore



#### 作品說明 Project Description

Eatsy 是一套多功能的餐具，裡頭包含了盤子、碗、杯子以及其他的容器。這些餐具的設計獨特、細膩，能夠避免髒污，而每一只餐具都有一個不同的點，能為視障者提供感官上的線索。這些都是普世共通的線索，適用於孩童、長者，甚至是需要特別協助的民眾。Eatsy 對於左撇子與右撇子的使用者而言同樣好用。

Eatsy is a set of multi-functional tableware which comes in the form of plate, bowl, cup, and utensils. They have a unique feature with subtle details that avoid stigmatization, and each piece has a distinctive spot to provide sensory cues for the visually impaired. They are universal, applicable for children, elderly and even people without special needs. Eatsy is user-friendly for both left and right-handed users, and they can be stacked up for easy storage.

## Eatsy



How might we deliver better dining opportunities for the visually impaired? To enhance the dining experience for the visually impaired, Eatsy is the solution.

Eatsy is a set of multi-functional tableware consisting of a plate, bowl, cup, and utensils. They each have unique features with subtle details that avoid stigmatization, and each piece has a distinctive spot to provide sensory cues for the visually impaired. They are universal, applicable for children, elderly and even people without special needs. All in all, Eatsy is a multi-functional tableware with good affordance that reduces food waste.

1



2

3



紐西蘭設計師協會特別獎  
DINZ Best Design Special Award

## 孤獨症

### Autism

作者姓名 Name of Designer(s)

趙丹婷、張丹妮

Dan-Ting Zhao, Dan-Ni Zhang

指導老師 Instructor(s)

郭磊

Lei Guo

學校所在地 Location of School

中國大陸

China

學校名稱 Name of School

中國美術學院

China Academy of Art



作品說明 Project Description

孤獨症眼中的世界可能比我們更加自由。

The world of autism may be more free than us.

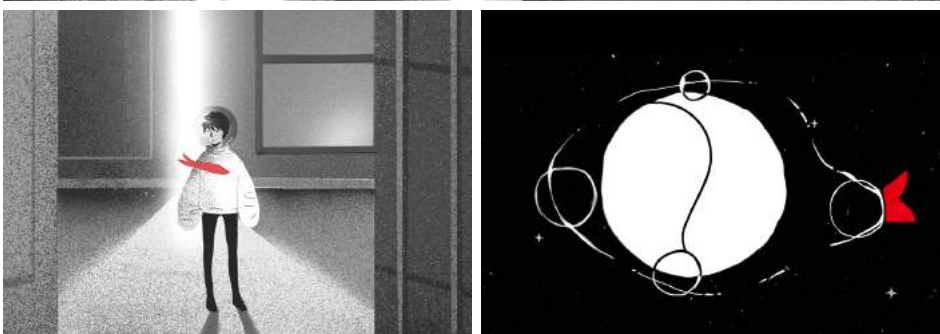
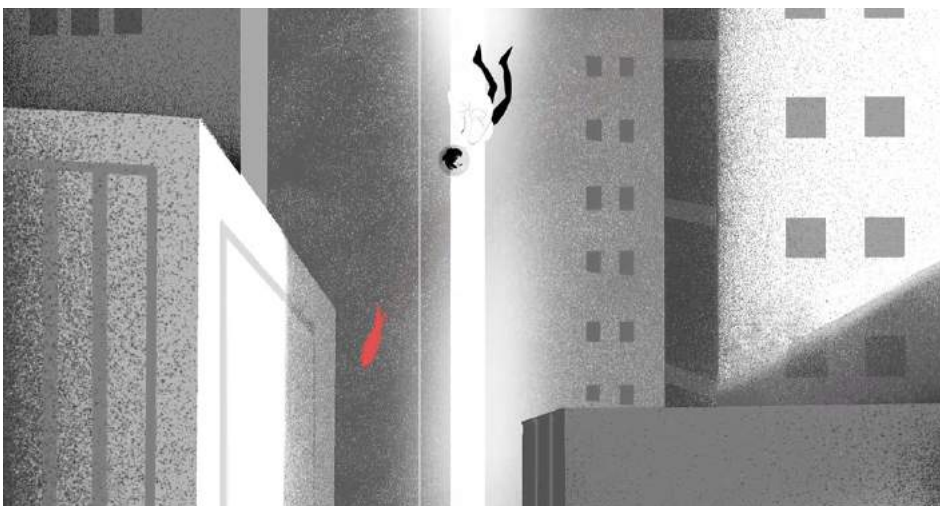





2017

# Opportunity

產品設計類得獎作品

Winners of Product Design Category



## 金獎作品評審講評 Jury Comments on Gold Prize

### 張漢寧 Jimmy Chang

臺灣 Taiwan

對於弱勢族群的關照一直是設計師們思考的方向，如何利用設計的導入讓弱勢族群更加便利與安全的生活，是評審團對於 Folks Kitchenware 一致認同高評價的原因，Folks Kitchenware 清楚的分析了視障者對於烹飪過程遭遇的困境，設計師以巧妙的結構設計與對於行為上的研究讓視障者在烹飪過程中更加便利安全，更值得嘉許的是設計者考量到改善使用者的心理障礙因素，這是我們在今年大賽產品設計類中給予 Folks Kitchenware 金獎的主要原因。

Care for the disadvantaged has always been a direction that designers think about. The reason why Folks Kitchenware receives unanimous high acclaim by the jurors is because it uses design to create a safer and more convenient life for disadvantaged individuals. Folks Kitchenware clearly analyzes the difficulties experienced by the visually impaired during cooking, and the designer applies clever structures based on behavioral research to make the cooking process safer and more convenient for them. What's also worth praise is that the designer even considers how to mitigate the psychological obstacles for the users. These are the main reasons why we awarded Folks Kitchenware the gold prize of the Product Design category in the Competition this year.

### 鍾雅涵 Kate Chung

臺灣 Taiwan

為自己料理食物對視覺障礙者是一件非常困難的事，此作品是針對料理過程中切刺食材以及液體傾倒的動作所設計的一組廚房用具，是用觸覺來輔助使用者以直覺性來使用這些器具，以提高進行烹飪前準備過程的安全性。此作品為視覺障礙者的生活提供了獨立使用廚房用具的機會，讓視覺障礙者生活更加便利，相當切合此次 Opportunity 主題。

For the visually impaired, cooking by themselves is a very difficult task. This piece of work is a set of kitchenware designed for cutting ingredients and pouring liquid in the process of cooking, and it applies tactile signals to help users use the kitchenware in an intuitive way, which enhances their safety during food preparation. This product provides an opportunity for the visually impaired to use kitchenware independently, hence making their lives easier and more convenient. This very much fits the theme of "Opportunity" this time.



## Folks Kitchenware for the Blind

作者姓名 Name of Designer(s)

Chiam Yong Sheng Kevin

指導老師 Instructor(s)

Song Kee Hong

學校所在地 Location of School

新加坡

Singapore

學校名稱 Name of School

新加坡國立大學

National University of Singapore



### 作品說明 Project Description

即便是對視覺正常的人而言，烹飪都可能令人心生畏懼，更何況是看不見的人。對失明者來說，由於他們得面對各種潑灑的不確定性，以及割傷／燒傷等受傷的危險，於是烹飪便成了一大挑戰。民族學研究顯示，這些差錯之所以發生，原因出在缺乏感官線索而導致的空間判斷不良。為了克服這一點，Folks Kitchenware 利用自然、感官的反饋以及觸覺的線索，讓失明者能有機會安全地烹飪，同時懷抱著自信與尊嚴。

Even with sight, cooking can be daunting, much less without vision. For the blind, preparing food becomes challenging as they cope with the uncertainties of spills and injuries like cuts/burns. Ethnography research shows that these slips happen due to poor spatial judgements caused by a lack of sensory references. To overcome this, Folks kitchenware leverages on natural, sensory feedback and tactile cues so that they can have the opportunity to prepare food safely with confidence and dignity.



#### PROBLEM FACED

An essential aspect of cooking is ingredient preparation. Regrettably, the blind who have suffered injuries from their early attempts with a kitchen knife develop tool phobia. It is to such an extent that it actually dissuades them from cooking. As it turns out, poor hand posture, with the combination of dull cutting tools and irregularly shaped ingredients put the user at high risks of getting cut.



#### PROPOSED SOLUTION - FOLKS KNIFE

To help them gain tool confidence, a retractable guard serves as a physical anchor and guides the fingers during the cutting process. This encourages blade contact, which is essentially safer. It also allows the blind to clean off any food that is stuck on the blade with a simple trigger. After usage, the guard can also be removed for cleaning with a simple push. Prototypes have been tested with 10 blind individuals over a course of 3 months and it has been proven effective in helping them gain confidence in cutting tasks.



#### COOKING FOR THE BLIND

folks





門鎖  
DoorBolt

作者姓名 Name of Designer(s)

徐文鑫、王子健、歐陽雪欣  
Wen-Xin Xu, Zi-Jian Wang,  
Xue-Xin Ouyang

指導老師 Instructor(s)

湯軍、李翔  
Jun Tang, Xiang Li

學校所在地 Location of School

中國大陸  
China

學校名稱 Name of School

武漢理工大學  
Wuhan University of Technology



作品說明 Project Description

這款產品設計就是對現有的房屋門把手進行的一次改進。目前的使用方式是我們需要在不同位置上設置其他的鎖扣用來加強防護，但是多個操作步驟很不方便。重新設計的把手具備了把手和門鎖的功能，當人們關上門以後將把手像古代的門闩一樣向左滑去，插入左側的鎖孔中，就可以給房門增加一道安全防護。這是一種具有中國傳統意義的解決方案，更重要的是，你可以清晰的看到房門有沒有被鎖住，這是一種全新的門鎖方式。

The design of product is an improvement for the door handle. And now we set up different locks in different locations to strengthen door, but the steps are very complex. The door handle we redesigned with handle and latch function, when closing door, people will slide handle to the left hole, which likes the ancient door bolt, it also add security to us. This is a traditional Chinese solution. And more importantly, you can clearly see the door has been locked, which is a new way to lock door.

# DoorBolt

设计的灵感起源于中国古代的闩门。古时候人们关门都需要用一根木条横着插在两个门把手中间，起到锁门的作用。

这款产品就是对现有的房屋门把手进行的一次改进。目前的使用方式是我们需要在不同位置上设置其他的锁扣用来加强防护，但是多个操作步骤很不方便。重新设计的把手具备了把手和门闩的功能，当人们关上门以后将把手像古代的闩门一样向左滑去，插入左侧的锁孔中，就可以给房门增加一道安全防护。这是一种方便，简单，安全又具有中国传统意义的解决方案，更重要的是，你可以清晰的看到房门有没有被锁住，这是一种全新的门锁方式。

**主要步骤:**

- 把手滑动到门把手位置，可以正常开门。
- 关门后，将把手向左滑动。
- 把手滑动到锁孔位置。
- 把手滑动到锁孔位置，门即被锁住。

**产品的优点:**

- 门上安装有两个锁孔。
- 把手滑动到锁孔位置时，用户可以清楚地看到把手是否插入锁孔。
- 把手滑动到锁孔位置时，用户可以清楚地看到把手是否插入锁孔。

这款产品是一种全新的门锁方式，通过把手和把手的滑动，用户可以清楚地看到门是否被锁住。

線 - 跨越

Across Line

作者姓名 Name of Designer(s)  
 陳子捷、袁千涵  
 Zih-Jie Chen, Chien-Han Yuan

指導老師 Instructor(s)  
 陳彥廷  
 Yan-Ting Chen

學校所在地 Location of School  
 臺灣  
 Taiwan

學校名稱 Name of School  
 國立臺灣科技大學  
 National Taiwan University of Science  
 and Technology



作品說明 Project Description

跨越一動詞，可以是人行為上的表現，例如跨越馬路、跨越斑馬線、跨越障礙等等。但是隨著生活日新月異的發展，跨越這樣的動詞也有不一樣的呈現方式。隨著交通的進步，生活的行動不再只局限於行走，便捷的交通運輸工具代替我們的雙腳，行走於地區與地區之間。利用自由的鞋帶纏繞方式代表穿梭於地點之間，配合不同的人有不同的腳型去選擇調整鞋帶的鬆緊，除了多變的造型外，也提升鞋子在腳上的舒適度。

"To step across" is one kind of human movement. For example, we can step across the road, step across the gap, or step across the obstacle. However, our lifestyle is changing and renewing rapidly. Our feet are replaced by the convenient vehicles in transportation mostly. In accordance, we can easily move in between two different areas not only by walking. By the free shoe lacing way, the tightness of laces can be adjusted according to different shapes of foot.

**ACROSS**

# ACROSS LINE

SHOES DESIGN  
CONCEPT DIAGRAM

**ACROSS CONCEPT**

"To step across" is one kind of human movement. For example, we can step across the road, step across the gap, or step across the obstacle.

However, our lifestyle is changing and renewing rapidly. Our feet are replaced by the convenient vehicles in transportation mostly. In accordance, we can easily move in between two different areas not only by walking.

**ACROSS**

DIFFERENT CHANGE OF SHOELACE STYLE

SHOES DESIGN

LACING SYSTEM

By the free shoe lacing way, the tightness of laces can be adjusted according to different shapes of foot. It creates the variable styles of footwear and makes our feet more comfortable putting the shoes on.

2

**ACROSS**

DIFFERENT CHANGE OF PEOPLE

SHOES DESIGN

FOR FAMILY

For the kids, the shoe lace design turns into the elastic band. Kids can change the laces in their favorite colors. The elastic band not only brings convenience, but also increases the fun of kids shoes.

3



漂浮護欄

Float Barrier

作者姓名 Name of Designer(s)

陳彥廷、陳彥廷、陳冠廷  
Yen-Tin Chen, Yen-Ting Chen,  
Guan-Tin Chen

指導老師 Instructor(s)

陳文印、黃子坤  
Wen-Yen Chen, T. K. Philip Hwang

學校所在地 Location of School

臺灣

Taiwan

學校名稱 Name of School

國立臺北科技大學  
National Taipei University of Technology



作品說明 Project Description

Float Barrier 是一款新型態漂浮警示，當豪雨來臨前工作人員將放置 Float Barrier 在路中，不僅有阻擋效用外，也會隨著淹水程度有所提高，能讓用路人與駕駛人能在 100M 外就能提早知道更換路線外，當洪水退後工作人員清理時也不必再次放置阻擋警示，當清理完畢後一起收起。

Float Barrier is a new type of floating warning sign. Float Barrier will be placed on the road before the heavy rain relevant. It not only serves as block but also rises with the increase of flood height. It allows passengers and drivers to change the route in advanced at a distance of 100M. After the flood the personnel do not need to place warning sign again and they can put it away when finishing cleaning.

**Float Barrier**  
漂浮護欄 - 警告標動化  
BLOCKING YOUR DANGEROUS!

**Background**

Global warming leads to global climate abnormality with the number of extreme rainfall in partial areas increases. Asia is regarded as the area where flood disasters occur most frequently and regularly in every year. When there are rainstorms and typhoons, low-lying areas and floodways are often flooded. Without ways to know the affected flood area, it frequently leads to roadside breakdown even threat life safety.

**Problem**

- The placement of current New Jersey's fences and road flooded sign relies on the human adjustment, due to the uncontrollable and unpredictable flooded level and extent.
- Traditional road flooded signs does not demonstrate the dangerous level according to the environmental factors which may lead to the disregard and the misjudgment of the sign for the driver.
- Current road flooded signs are not synchronized, this make the recognition of the signs troublesome and may also cause excessive mental workload for the driver.

**Concept**

Float Barrier is a new type of floating warning sign. Float Barrier will be placed on the road before the heavy rain relevant. It not only serves as block but also rises with the increase of flood height. It allows passengers and drivers to change the route in advanced at a distance of 100M. After the flood the personnel do not need to place warning sign again and they can put it away when finishing cleaning.

Process description

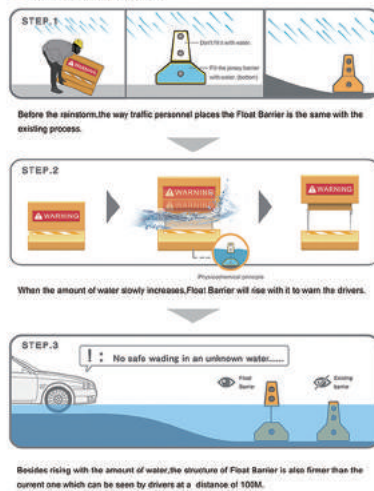

Product mechanism

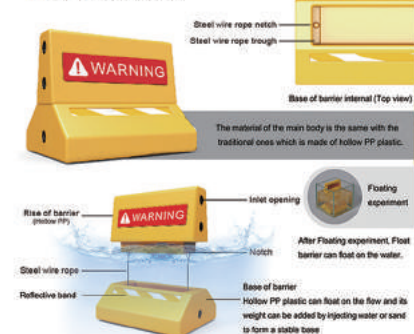

Product Measurement





**Aero**

作者姓名 Name of Designer(s)  
Janis Beinerts, Susanne Duswald

指導老師 Instructor(s)  
Thomas Degn

學校所在地 Location of School  
瑞典  
Sweden

學校名稱 Name of School  
優密歐大學  
Umeå University



作品說明 Project Description

園藝能為城市創造出不同凡響的價值。然而在短短十年之後，我們就將遭遇全球百分之四十的水源短缺，而這將使得園藝成為一項昂貴的活動。有鑑於此，在未來人口密集的城市裡，AERO 的設計能以一種環保的方式，為缺水地區收集空氣中的濕氣。AERO 配備了創新科技，每天能產生兩百公升的水，而水將由社區所共享。AERO 能幫助使用者追蹤水資源利用的情況，並透過園藝把人們連結起來。

Gardening creates a great value for cities. But already in a decade, we will suffer a 40% shortage of water globally, which makes gardening an expensive activity. Therefore AERO was created for dense future cities in low water areas to harvest humidity in environmentally friendly way. Equipped with innovative technology, AERO can produce up to 200L of water per day that is shared by the community. AERO helps the users to keep track of their water consumption and connects them through gardening.





城市養蜂計畫  
Beekeeper

作者姓名 Name of Designer(s)

梁哲誠

Che-Cheng Liang

指導老師 Instructor(s)

伍大忠

Ta-Chung Wu

學校所在地 Location of School

臺灣

Taiwan

學校名稱 Name of School

實踐大學

Shih Chien University



作品說明 Project Description

城市蜂箱，是設計給在家中陽臺養蜂的人所使用的蜂箱。在蜂箱中可完成養殖和取蜜的工作；螺旋狀的蜂巢片結構可以使蜂蜜透過離心力甩出，從下方流入瓶中，不但節省空間也讓養蜂的過程更加輕鬆安全。

Beekeeper is designed to be used by beekeepers who keep their bees on their balcony at home. The beehive allows for the breeding of bees and the collection of honey. In addition, the structure of the honeycomb is spiral in shape, so that you can collect the honey by means of the centrifugal force, after which the honey flows into the bottom of the bottle. This design not only saves space, but also makes the process of keeping bees easier and safer.



Beekeeper  
城市養蜂計畫

**Project brief /** The City Beehive is designed to be used by beekeepers who keep their bees on their balcony at home. The beehive allows for the breeding of bees and the collection of honey. In addition, the structure of the honeycomb is spiral in shape, so that you can collect the honey by means of the centrifugal force, after which the honey flows into the bottom of the bottle. This design not only saves space, but also makes the process of keeping bees easier and safer.

城市蜂箱，是設計給在家中陽臺養蜂的人所使用的蜂箱。在蜂箱中可完成養殖和取蜜的工作；螺旋狀的蜂巢片結構可以使蜂蜜透過離心力甩出，從下方流入瓶中，不但節省空間也讓養蜂的過程更加輕鬆安全。



**Trend /** Since the loss of the global bee population in 2006, people have become more aware of the ecological imbalance, and have begun to consider the possibility of keeping bees in urban environments. Through urban beekeeping, we hope to improve the crisis of bee disappearance and benefit the urban ecology.

自從2006年全球蜜蜂大量消失後，人們開始意識到城市生態平衡，也開始思考如何養蜂的可能性，希望透過城市養蜂改善環境問題並提升城市生態環境。

Why are bees important?



Flow /





巧取

Easy Unplug

作者姓名 Name of Designer(s)  
馬德宇、韋宗坡、魏士杰  
De-Yu Ma, Zong-Po Wei, Shi-Jie Wei

指導老師 Instructor(s)  
包海默、許坤、喬松  
Hai-Mo Bao, Kun Xu, Song Qiao

學校所在地 Location of School  
中國大陸  
China

學校名稱 Name of School  
大連民族大學  
Dalian Nationalities University



作品說明 Project Description

插頭在使用時常會有一些小的困擾，例如插的過緊無法拔出，插頭較多時無法分辨，黑暗環境中不容易看見等。巧取插頭通過中間設置的一個帶顏色的推拉按鍵可以將以上問題得到解決。最重要的功能是用戶可以輕鬆的單手拔出緊緊固定在插排上的插頭，也更加安全。當然，用戶也可以通過按鍵的顏色來判斷與之相連的電器，也可以通過按鍵發出的微弱光線來實現黑暗中的查找。

Several problems often trouble us when we use the plug. For example, it is too tight to be pulled out of the socket, difficult to be distinguished from others when they are overlapped, and not easy to be located in dark. The pressing head designed with different colors will help us to some extent. Firstly, it can be pressed down just by one hand, raising the plug from the tight socket. Secondly, various colors mean various devices, which help us to find the correct plug quickly. The weak light in dark makes the plug easy to be located.



巧·取  
Easy Unplug

插頭在使用時常會有一些小的困擾，例如插的過緊無法拔出，插頭較多時無法分辨，黑暗環境中不容易看見等。易拔插頭通過中間設置的一個帶顏色的推拉按鍵可以將以上問題得到解決。最重要的功能是用戶可以輕鬆的單手拔出緊緊固定在插排上的插頭，也更加安全。當然，用戶也可以通過按鍵的顏色來判斷與之相連的電器，也可以通過按鍵發出的微弱光線來實現黑暗中的查找。

Several problems often trouble us when we use the plug. For example, it is too tight to be pulled out of the socket, difficult to be distinguished from others when they are overlapped, and not easy to be located in dark. The pressing head designed with different colors will help us to some extent. Firstly, it can be pressed down just by one hand, raising the plug from the tight socket. Secondly, various colors mean various devices, which help us to find the correct plug quickly. The weak light in dark makes the plug easy to be located.



**巧·取**

**背景问题/BACKGROUND**

上圖展示了現有插頭的問題，各種插頭的可視性差，安裝困難，可以導致多個插頭同時插入，導致發熱、電壓不穩定，不可預測的損壞設備和電路安全。當實現輕松拔插。

The above figure shows the using situation of the ordinary plug, which is distinguished and dangerous. It can be found that if multiple plugs are not distinguishable to be inserted, there is a fire hazard between them. Their features: their usage is difficult to be observed, but the operation, it is a great need to realize when they are corresponding to:

嚴重中的設置的複雜結構和插頭頭部發熱的現象，應則簡單而開關五個零件簡單即可安裝。採集插頭發熱和危險，增加了安全性。

The above picture shows the design of the "Easy Unplug" which is easy to be observed with a reasonable strength, which can be operated just by one hand. This not only prevents the original shape of the plug, but also increases safety.

**产品尺寸/SIZE**

**使用过程/PROCESS**

插入插頭時，按鍵在手指下操作  
The head is down before being used.

插入插頭時，按鍵在手指下操作  
The head is up when being used.

按鍵在手指下，按鍵在中間位置  
Press the plug in the middle part with the middle finger and middle finger, and at the same time, press the head with thumb.

用插頭之向下力在按鍵，按鍵在中間位置  
Press the head with thumb and middle finger, and at the same time, press the plug in the middle part with the middle finger and middle finger. The plug can be taken out just by one hand.

**产品结构/STRUCTURE**

不同顏色的按鍵可以作為識別符，避免混淆之類型的不同電器，防止混亂中誤操作。

Different colors can be used as marks to distinguish plugs, so as to find the correct one for certain device. We will not just the plug by mistake any more.

插頭發熱，不同顏色的按鍵可以作為識別符，方便黑暗環境下安裝。

The colorful head emits weak light when being used, that is convenient to dark environment.

共同呼吸

Breathe Together

作者姓名 Name of Designer(s)  
趙忠文、楊揚、林子傲  
Zhong-Wen Zhao, Yang Yang, Zi-Ao Lin

指導老師 Instructor(s)  
包海獸、許坤、喬松  
Hai-Mo Bao, Kun Xu, Song Qiao

學校所在地 Location of School  
中國大陸  
China

學校名稱 Name of School  
大連民族大學  
Dalian Nationalities University



共同呼吸 O<sub>2</sub> Breathe Together

作品說明 Project Description

火災發生時，多數遇難者都是由於吸入過多的濃煙而導致缺氧造成的，而且即使吸入少量的濃煙也會造成一定程度的昏迷。救援隊員進入火場時，往往只攜帶一個氧氣罐，無法為受困人員提供氧氣。“共同呼吸”是一款帶有兩個氧氣面罩的救援設備，可以讓救援人員在第一時間給受困者也提供相同的氧氣供應，最大程度保證救援的成功。同時，得到氧氣供應的受困者也會更加快速的運動和配合救援工作。

Most of the victims died from breathing in too much smoke and lacking of oxygen in a fire. Even not too much smoke will also cause coma. The fireman often brings one oxygen tank to decrease burden, but this ignores consideration of the trapped person. "Breathe together" is equipment with two oxygen outlets, one for the fireman and one for the trapped person. With oxygen, the trapped person is also easy to be rescued.

Most of the victims died from breathing in too much smoke and lacking of oxygen in a fire. Even not too much smoke will also cause coma. The fireman often brings one oxygen tank to decrease burden, but this ignores consideration of the trapped person. "Breathe together" is equipment with two oxygen outlets, one for the fireman and one for the trapped person. With oxygen, the trapped person is also easy to be rescued.

火灾发生时，多数遇难者都是由于吸入过多的浓烟而导致缺氧造成的，而且即使吸入少量的浓烟也会造成一定程度的昏迷。救援队进入火场时，往往只携带一个氧气罐，无法为受困人员提供氧气。“共同呼吸”是一款带有两个氧气面罩的救援设备，可以让救援人员在第一时间给受困者也提供相同的氧气供应，最大程度保证救援的成功。同时，得到氧气供应的受困者也会更加快速的运动和配合救援工作。



**Background**

Most of the victims are suffered from lacking of oxygen in the fire, And the fireman has only one oxygen outlet for himself, with no extra one for the trapped person. This is not good enough for the trapped person.

**Past**

The fireman has only one oxygen outlet for himself

**Now**

"Breathe Together" is equipment with two oxygen outlets, one for the fireman and one for the trapped person.

When the fire broke out, most of the children, due to lacking of emergency rescue ability, so they need to be rescued at the first time. The advantage of this device is that the fireman can already have the child at his arms and give oxygen. In the process of fleeing the scene of the fire, the child could get enough oxygen to get out to free his life.

**Details**

**Using Process**



## Multi-function safety barrier



在中国一些建筑工地集中的地方，总能看到一些建筑工人在工地吃饭的场景，他们或用安全帽作凳、或蹲、或就地而坐；在工地时常会有意外发生造成工人受伤。本着对农民工群体的关怀，在安全护栏的基础上增加了座椅、餐桌以及意外发生时用的担架功能，让工人在放心工作的同时能够休息、吃饭，保障了工人的基本权益。

In some areas of construction site concentration in China, we can often see the sight of workers eating some of them sit on the helmet, some squat and some sit on the ground, the accident happens sometime make the workers injured. In line with concern for peasant-worker, we increase some function base on the safety guardrail include seat, dining table and stretcher, guarantee the basic rights of workers.

### Multi-function safety barrier



### Multi-function safety barrier

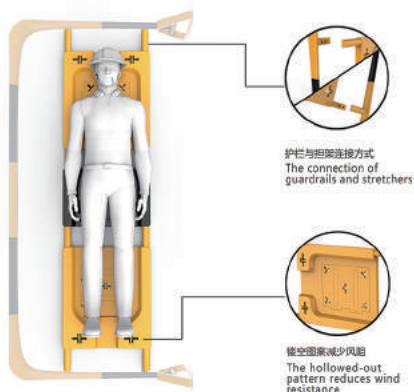

## 多功能安全護欄

### Multi-Function Safety Barrier

作者姓名 Name of Designer(s)

楊帥、文懷奇

Shuai Yang, Huai-Qi Wen

指導老師 Instructor(s)

王天宇

Tian-Yu Wang

學校所在地 Location of School

中國大陸

China

學校名稱 Name of School

遼寧工業大學

Liaoning University of Technology



### 作品說明 Project Description

在中國一些建築工地集中的地方，總能看到一些建築工人在工地吃飯的場景，他們或用安全帽作凳、或蹲、或就地而坐；在工地時常會有意外發生造成工人受傷。本著對農民工群體的關懷，在安全護欄的基礎上增加了座椅、餐桌以及意外發生時用的擔架功能，讓工人在放心工作的同時能夠休息、吃飯，保障了工人的基本權益。

In some areas of construction site concentration in China, we can often see the sight of workers eating, some of them sit on the helmet, some squat and some sit on the ground, the accident happens sometime make the workers injured. In line with concern for peasant-worker, we increase some function base on the safety guardrail include seat, dining table and stretcher, guarantee the basic rights of workers.

The Urban Yield

作者姓名 Name of Designer(s)  
Dylan Sheppard, David Chapman

指導老師 Instructor(s)  
無  
None

學校所在地 Location of School  
澳洲  
Australia

學校名稱 Name of School  
昆士蘭科技大學  
Queensland University of Technology



作品說明 Project Description

「都市收成」(The Urban Yield) 是一項設計企畫，提倡一個以腳踏車為基礎的送貨網絡，藉此在城市中運輸新鮮的農產品。這個系統致力於將都市裡的農作物栽種者、後院小農以及社區園藝師連結起在地的餐廳和咖啡館。這項企畫的重點是，在都市社區中打造並支持環保永續的實踐作為，提供產品、系統與服務來促進、鼓勵社區行動，並以栽種和運送農產品為核心。

The Urban Yield is a design project proposing a bicycle based courier network for moving fresh produce throughout cities. The aim of the system is to connect urban produce growers, backyard farmers and community gardeners, to local cafes and restaurants. The project focuses on building and supporting sustainable practices within urban communities, through providing the products, systems and services to facilitate and encourage community action surrounding growing and transporting produce.

THE URBANYIELD

The Urban Yield is a service design project proposing a bicycle based courier network for moving fresh produce throughout Brisbane's CBD and surrounding cultural and social hubs.

The primary function of the Urban Yield system is to connect urban fresh produce growers, backyard farmers and community gardeners, to local cafes and restaurants.

The project as a whole focuses on building and supporting sustainable practices within urban communities, through providing the products, systems and services to facilitate and encourage community action surrounding growing and transporting produce.

The project aims to take advantage of the opportunity to connect the two emerging trends of bicycle urbanism and urban agriculture to produce an economically sound, environmentally conscious and community orientated food mobility network.

By providing a mobility infrastructure, in the form of specialised cargo bicycles, the system aims to promote urban agriculture practices and encourage community engagement in localised food production and distribution.

The issues of food security, sustainability and urban agricultural infrastructure are truly not unique to Australia. Globally cities are becoming more bicycle friendly, and still face many of the same issues as our own local research discovered.

How do we support urban agriculture in our cities?

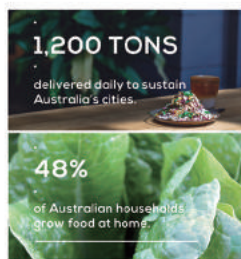

The Product

The Urban Yield bike makes use of aluminium-reinforced epoxy frames, designed to support the exchange and handling of produce, with innovative fastening and retention straps.

The bike is designed to suit the urban city streets, with a durable, light and manoeuvrable design. The integrated dog system allows for modularity, and enables the rider to adjust the configuration of boxes and bins to suit each delivery.

Together, the design of the bike, racks and boxes work to support the system as a whole by delivering an efficient and durable design solution.



**The UI**  
The aspects of the Urban Yield business, connecting growers, identifying growers and supplying restaurants are all handled through an integrated application interface.

The primary user in the system is the produce grower, and so much the interface design is focused on delivering a seamless user experience to support their growing habits, and facilitate the sale and shipping of food they grow.



The restaurant section of the Urban Yield app allows users to request produce, track seasonal harvests and identify key growers in their area.

The restaurants can tailor their orders to the crops of the participating growers, as well as uploading menus to assist the growers in deciding what to grow.



The navigation app allows cyclists to optimise their route, identify information about their pick-ups before they arrive, schedule deliveries and manage to their destination in time.

The app also handles payments to streamline the user interaction through all levels of the service.

connecting urban growers to local cafes and restaurants.





植生磚

Green Slab

作者姓名 Name of Designer(s)

陶俊蓉

Chun-Jung Tao

指導老師 Instructor(s)

陳彥廷

Yan-Ting Chen

學校所在地 Location of School

臺灣

Taiwan

學校名稱 Name of School

國立臺灣科技大學

National Taiwan University of Science and Technology



作品說明 Project Description

將植生牆的概念結合板磚，將不同種類的種子放在板磚內，板磚為木屑再次加工利用。種子藉由雨水以及牆面的冷氣水吸收水分成長。五邊形的形狀可以自由式組合，適合任何大小的牆壁。此外，該技術加以利用雨水並重複使用二次水，植物有助於淨化空氣污染且美化牆面。植生磚提供新鮮空氣，並有助於降低室內和室外的溫度，將城市變為一個舒適的藝術花園。

In order to combine plant wall with wallboard, seeds of different species are put inside the wallboard. The seeds grow while absorbing the rainwater in which brings greeneries and energizes the environment. The pentagon shape allows freestyle combination that fits walls of any size. Moreover, the technique saves and reuses water, the plants help purifying the mild-contaminated-water while absorbing the substances in it. The plant wall provides fresh air and helps cooling down the temperature in both indoor and outdoor, which turns a city into a cozy artistic garden.



## A/B/O: Blood Bags

作者姓名 Name of Designer(s)

Ciara Little

指導老師 Instructor(s)

無

None

學校所在地 Location of School

英國

United Kingdom

學校名稱 Name of School

雪菲爾哈倫大學

Sheffield Hallam University



### 作品說明 Project Description

「A/B/O：血袋」(A/B/O: Blood Bags) 是明確顯示出血型的輸血包。這項設計是為了避免醫療上的失誤，因為一旦輸錯 ABO 等血型，只要輸血十毫升就足以致命。這項產品聚焦於三大要素：1. 形狀：每一個血袋在視覺上都突顯了相應的 ABO 等血型。2. 擁有先進的標記系統，能透過 NFC 技術安全儲存資料，並簡化圖形上的格式。3. 連接器系統以感官線索為基礎，只有相對應的連結才能成功有效。

"A/B/O: Blood Bags" are blood type specific transfusion kits. Designed to prevent medical error where as little as 10ml of the wrong ABO blood type can be fatal. The product focuses on three main elements: 1.The form, each bag visually representing the corresponding ABO blood type. 2.A pioneering labelling system, with NFC technology securely storing data and simplifying the graphical format. 3.The connector system, based on sensory cues, allows only corresponding connections to be made.







家用哑铃改良设计  
Home - Use Dumbbell Reform Design

作者姓名 Name of Designer(s)  
王仲治、劉軍、李冠豪、蘆宇航  
Zhong-Zhi Wang, Jun Liu, Billy Li, Scarus Lu

指導老師 Instructor(s)  
倉詩建  
Shi-Jian Cang

學校所在地 Location of School  
中國大陸  
China

學校名稱 Name of School  
天津科技大學  
Tianjin University of Science & Technology

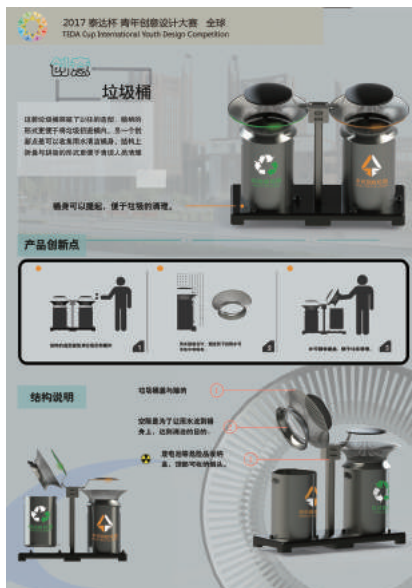

創新垃圾桶  
Innovative Trash Can

作者姓名 Name of Designer(s)  
張志遠  
Victor Chang

指導老師 Instructor(s)  
倉詩建、劉琳琳  
Shi-Jian Cang, Lin-Lin Liu

學校所在地 Location of School  
中國大陸  
China

學校名稱 Name of School  
天津科技大學  
Tianjin University of Science & Technology



時間與機會手錶  
The Watch of Time and Opportunity

作者姓名 Name of Designer(s)  
余意  
Yi Yu

指導老師 Instructor(s)  
無  
None

學校所在地 Location of School  
中國大陸  
China

學校名稱 Name of School  
天津科技大學  
Tianjin University of Science & Technology







**無煙食堂**  
**Dining & Fumes Free**

作者姓名 Name of Designer(s)  
林家齊、謝佳儒  
Chia-Chi Lin, Jia-Ru Sie

指導老師 Instructor(s)  
宋毅仁  
I-Zen Sung

學校所在地 Location of School  
臺灣  
Taiwan

學校名稱 Name of School  
國立高雄師範大學  
National Kaohsiung Normal University



**線盒**  
**Line Box**

作者姓名 Name of Designer(s)  
林春鋒、彭勁超  
Chun-Feng Lin, Jin-Chao Peng

指導老師 Instructor(s)  
柳翔宇  
Xiang-Yu Liu

學校所在地 Location of School  
中國大陸  
China

學校名稱 Name of School  
廣東輕工職業技術學院  
Guangdong Industry Technical College



**90° 哮喘瓶**  
**90° Asthma Bottle**

作者姓名 Name of Designer(s)  
林春鋒、彭勁超  
Chun-Feng Lin, Jin-Chao Peng

指導老師 Instructor(s)  
柳翔宇  
Xiang-Yu Liu

學校所在地 Location of School  
中國大陸  
China

學校名稱 Name of School  
廣東輕工職業技術學院  
Guangdong Industry Technical College

**折疊護欄**  
**Folding Guardrail**

作者姓名 Name of Designer(s)

張中陽、陶藍

Zhong-Yang Zhang, Lan Tao

指導老師 Instructor(s)

歐陽國輝

Guo-Hui Ouyang

學校所在地 Location of School

中國大陸

China

學校名稱 Name of School

長沙理工大學

Changsha University of Science & Technology



**國際難民救難包**  
**Life-Pack**

作者姓名 Name of Designer(s)

張伊如、桑睿

Yi-Ju Chang, Rui Sang

指導老師 Instructor(s)

謝毓琛

Chester Hsieh

學校所在地 Location of School

臺灣

Taiwan

學校名稱 Name of School

國立雲林科技大學

National Yunlin University of Science and Technology



**友善耕作水田除草機**  
**Organic Agriculture Paddy Field Brush Cutter**

作者姓名 Name of Designer(s)

林國新、黃郁佩

Guo-Shin Lin, Yu-Pei Huang

指導老師 Instructor(s)

翁註重

Ju-Joan Wong

學校所在地 Location of School

臺灣

Taiwan

學校名稱 Name of School

國立雲林科技大學

National Yunlin University of Science and Technology





**Forthcoming**

作者姓名 Name of Designer(s)  
 魏啟翀  
 Qi-Chong Wei  
 指導老師 Instructor(s)  
 無  
 None  
 學校所在地 Location of School  
 中國大陸  
 China  
 學校名稱 Name of School  
 廣州美術學院  
 Guangzhou Academy of Fine Arts



**Snark**

作者姓名 Name of Designer(s)  
 魏啟翀  
 Qi-Chong Wei  
 指導老師 Instructor(s)  
 無  
 None  
 學校所在地 Location of School  
 中國大陸  
 China  
 學校名稱 Name of School  
 廣州美術學院  
 Guangzhou Academy of Fine Arts



**Dang Dang Dang**

作者姓名 Name of Designer(s)  
 程碧亮、洪思展、劉北方  
 Bi-Liang Cheng, Si-Zhan Hon,  
 Bei-Fang Liu  
 指導老師 Instructor(s)  
 張劍  
 Jian Zhang  
 學校所在地 Location of School  
 中國大陸  
 China  
 學校名稱 Name of School  
 廣州美術學院  
 Guangzhou Academy of Fine Arts



智能護理

NHQ

作者姓名 Name of Designer(s)  
 詹淑慧、廖典瑛、石博丞  
 Shu-Hui Chan, Tien-Chuan Liao,  
 Po-Cheng Shih

指導老師 Instructor(s)  
 范政揆、董正勇  
 Cheng-Kuei Fan, Cheng-Yung Tung

學校所在地 Location of School  
 臺灣  
 Taiwan

學校名稱 Name of School  
 國立臺北科技大學  
 National Taipei University of Technology



Six-By-Six-Thermometer for Eye

作者姓名 Name of Designer(s)  
 Pratik Raj, Anusha Mangal

指導老師 Instructor(s)  
 無  
 None

學校所在地 Location of School  
 印度  
 India, United States

學校名稱 Name of School  
 國立設計學院 (邦加羅爾)、  
 華盛頓大學  
 National Institute of Design, Bangalore,  
 University of Washington

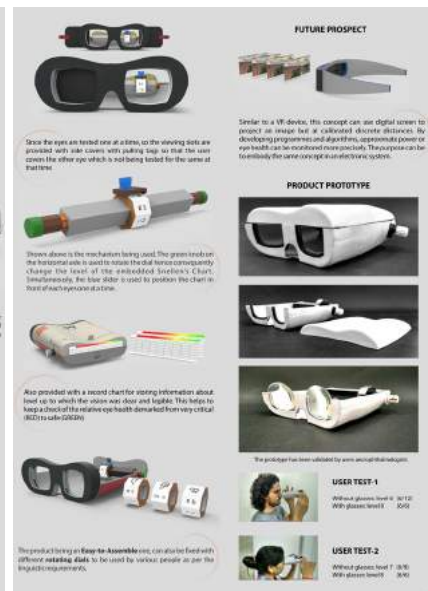

自肢

Bokit

作者姓名 Name of Designer(s)  
 羅景儀  
 Ching-Yi Lo

指導老師 Instructor(s)  
 翁瑞津  
 Ruey-Jin Wong

學校所在地 Location of School  
 臺灣  
 Taiwan

學校名稱 Name of School  
 大同大學  
 Tatung University





**蛻變 Metamorphosis**

作者姓名 Name of Designer(s)  
黃祈軒  
Andy Huang  
指導老師 Instructor(s)  
李鎔朮  
Kai-Chi Lee  
學校所在地 Location of School  
臺灣  
Taiwan  
學校名稱 Name of School  
國立臺北教育大學  
National Taipei University of Education

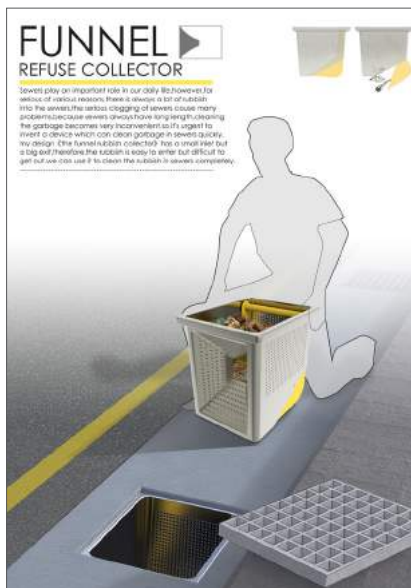
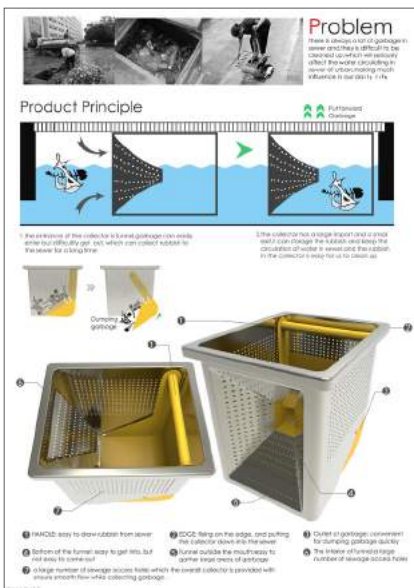

**快速清潔下水道的垃圾 Funnel**

作者姓名 Name of Designer(s)  
開程飛  
Cheng-Fei Kai  
指導老師 Instructor(s)  
無  
None  
學校所在地 Location of School  
中國大陸  
China  
學校名稱 Name of School  
中南大學  
Central South University



**Bam**

作者姓名 Name of Designer(s)  
David Jonathan Ui  
指導老師 Instructor(s)  
無  
None  
學校所在地 Location of School  
新加坡  
Singapore  
學校名稱 Name of School  
南洋藝術學院  
Nanyang Academy of Fine Arts

'Titch

作者姓名 Name of Designer(s)  
Thomas Lauanders

指導老師 Instructor(s)  
無  
None

學校所在地 Location of School  
英國  
United Kingdom

學校名稱 Name of School  
雪菲爾哈倫大學  
Sheffield Hallam University



好釘

Nail It

作者姓名 Name of Designer(s)  
陳柏丞  
Po-Cheng Chen

指導老師 Instructor(s)  
無  
None

學校所在地 Location of School  
臺灣  
Taiwan

學校名稱 Name of School  
大同大學  
Tatung University



不倒翁砧板

Tumbler Chopping Board

作者姓名 Name of Designer(s)  
于曉航、董樹、向冬桃  
Xiao-Hang Yu, Shu Dong, Dong-Tao Xiang

指導老師 Instructor(s)  
翁註重  
Ju-Joan Wong

學校所在地 Location of School  
中國大陸  
China

學校名稱 Name of School  
浙江工商大學  
Zhejiang Gongshang University





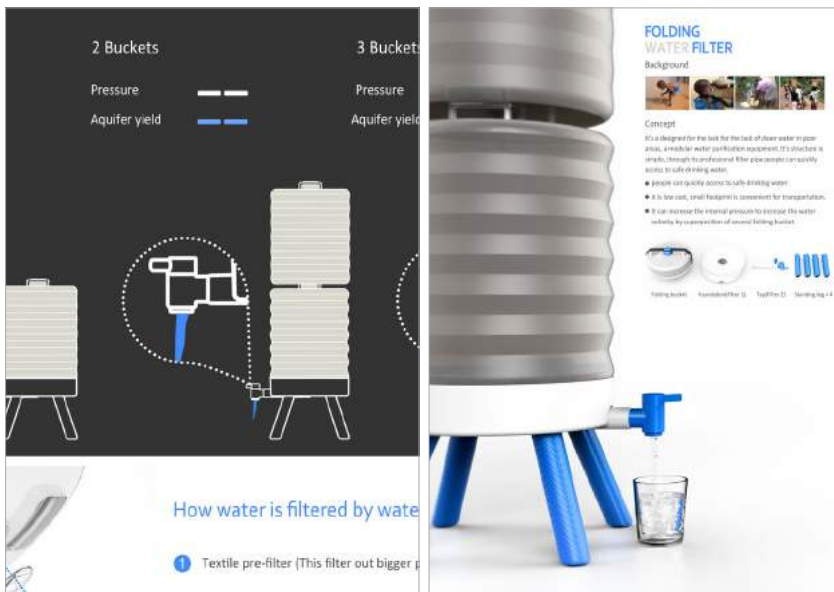

可折疊式水桶  
**Folding Water Filter**

作者姓名 Name of Designer(s)  
劉滄  
Wei Liu  
指導老師 Instructor(s)  
黎英、柯勝海  
Ying Li, Sheng-Hai Ke  
學校所在地 Location of School  
中國大陸  
China  
學校名稱 Name of School  
湖南工業大學  
Hunan University of Technology



生命補丁  
**Life Patch for Lifebuoy**

作者姓名 Name of Designer(s)  
劉滄  
Wei Liu  
指導老師 Instructor(s)  
黎英  
Ying Li  
學校所在地 Location of School  
中國大陸  
China  
學校名稱 Name of School  
湖南工業大學  
Hunan University of Technology



環保藥水袋  
**Zero Polluting**

作者姓名 Name of Designer(s)  
邱曼庭  
Man-Ting Chiou  
指導老師 Instructor(s)  
黃孟帆  
Meng-Fan Huang  
學校所在地 Location of School  
臺灣  
Taiwan  
學校名稱 Name of School  
國立臺北科技大學  
National Taipei University of Technology

## 隔絕者登山帳篷 Secluder Backpacking Tent

作者姓名 Name of Designer(s)

耿祐中  
Yu-Chung Ken

指導老師 Instructor(s)

孫崇實  
Chung-Shih Sun

學校所在地 Location of School

臺灣  
Taiwan

學校名稱 Name of School

實踐大學  
Shih Chien University



## 提示訂書釘 Alert Stapler

作者姓名 Name of Designer(s)

于丹、李文凱  
Dan Yu, Wen-Kai Li

指導老師 Instructor(s)

無  
None

學校所在地 Location of School

中國大陸  
China

學校名稱 Name of School

湖北美術學院  
Hubei Institute of Fine Arts



## 竹光 Bamboo Emergency Light Design

作者姓名 Name of Designer(s)

丁涵茹、蘇意雲、劉怡汝、吳姿螢、陳淑雅  
Han-Ru Ding, Yi-Yun Su, Yi-Ru Liu, Zi-Ying Wu, Su-Ya Chen

指導老師 Instructor(s)

閔嬰紅  
Ying-Hong Yan

學校所在地 Location of School

臺灣  
Taiwan

學校名稱 Name of School

亞東技術學院  
Oriental Institute of Technology





駁 Pelion

作者姓名 Name of Designer(s)  
劉振德、張睿夫、丘澤俊  
Chen-Te Liu, Jui-Fu Chang, Chet-Chim Kiu

指導老師 Instructor(s)  
黃鼎德、伍大忠  
Ting-Yi Huang, Da-Chung Wu

學校所在地 Location of School  
臺灣  
Taiwan

學校名稱 Name of School  
實踐大學  
Shih Chien University

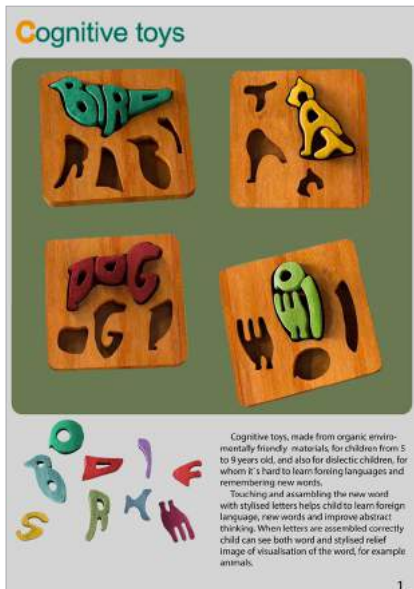
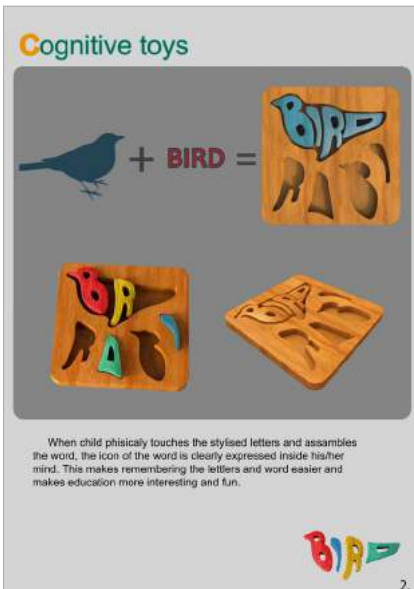

Cognitive Toys

作者姓名 Name of Designer(s)  
Tamaz-Arunashvili, Mariam-Amashukeli

指導老師 Instructor(s)  
無  
None

學校所在地 Location of School  
喬治亞  
Sakartvelo

學校名稱 Name of School  
第比利斯國立藝術學院  
Tbilisi State Academy of Art



躍樂 / 視障兒童音樂玩具  
Yueyue / Musical Toy for Visually Impaired Children

作者姓名 Name of Designer(s)  
凌志豪  
Zhi-Hao Ling

指導老師 Instructor(s)  
無  
None

學校所在地 Location of School  
中國大陸  
China

學校名稱 Name of School  
廈門大學嘉庚學院  
Xiamen University Tan Kah Kee College



## 易開罐旋轉蓋 Rotatable Lid of Beverage Can

作者姓名 Name of Designer(s)  
 鐵錦煥  
 Jin-Huan Yi

指導老師 Instructor(s)  
 陳彥廷  
 Yan-Ting Chen

學校所在地 Location of School  
 臺灣  
 Taiwan

學校名稱 Name of School  
 國立臺灣科技大學  
 National Taiwan University of Science  
 and Technology

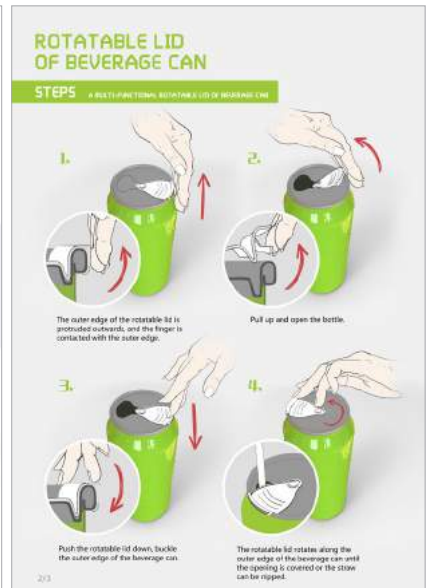

## Bikeg 單車調度 Bikeg Bicycle Transport

作者姓名 Name of Designer(s)  
 余凱明  
 Kinsey Yu

指導老師 Instructor(s)  
 無  
 None

學校所在地 Location of School  
 香港  
 Hong Kong

學校名稱 Name of School  
 伯明翰城市大學  
 Birmingham City University



## 76 度的微醺 Brew in 76°C

作者姓名 Name of Designer(s)  
 梁哲誠  
 Che-Cheng Liang

指導老師 Instructor(s)  
 伍大忠  
 Yu-Lung Yang

學校所在地 Location of School  
 臺灣  
 Taiwan

學校名稱 Name of School  
 實踐大學  
 Shih Chien University





**雙喜火柴盒**  
**"Double Happiness" Matchbox**

作者姓名 Name of Designer(s)

竹科英

Ke-Ying Zhu

指導老師 Instructor(s)

張劍

Jian Zhang

學校所在地 Location of School

中國大陸

China

學校名稱 Name of School

廣州美術學院

Guangzhou Academy of Fine Arts



**雪地積水杯**

**Dropper**

作者姓名 Name of Designer(s)

何璐君

Lu-Jun He

指導老師 Instructor(s)

李奮強

Fen-Qiang Li

學校所在地 Location of School

中國大陸

China

學校名稱 Name of School

蘭州理工大學

Lanzhou University of Technology



**平**

**Pin; Flattening Project**

作者姓名 Name of Designer(s)

陳郁安

Yu-An Chen

指導老師 Instructor(s)

王俊隆

Rock Wang

學校所在地 Location of School

臺灣

Taiwan

學校名稱 Name of School

實踐大學

Shih Chien University

### Malachi

作者姓名 Name of Designer(s)  
 楊智傑  
 Chih-Chieh Yang  
 指導老師 Instructor(s)  
 無  
 None  
 學校所在地 Location of School  
 美國  
 United States of America  
 學校名稱 Name of School  
 舊金山藝術大學  
 Academy of Art University

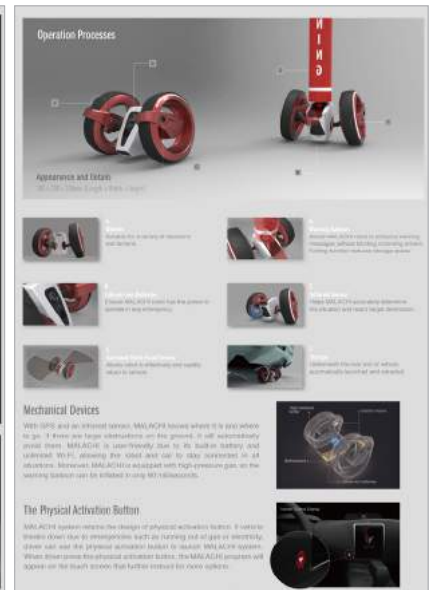

### 新型態海葬骨灰罇 Soul of Sea

作者姓名 Name of Designer(s)  
 陳大川  
 Ta-Chuan Chen  
 指導老師 Instructor(s)  
 林曉瑛  
 Hsiao-Ying Lin  
 學校所在地 Location of School  
 臺灣  
 Taiwan  
 學校名稱 Name of School  
 實踐大學  
 Shih Chien University



### Finger Saver

作者姓名 Name of Designer(s)  
 Kimin Choi, Eunjeong Kim,  
 Chaewon Seo, Jinwook Shin  
 指導老師 Instructor(s)  
 無  
 None  
 學校所在地 Location of School  
 韓國  
 Korea  
 學校名稱 Name of School  
 啟明大學  
 Keimyung University

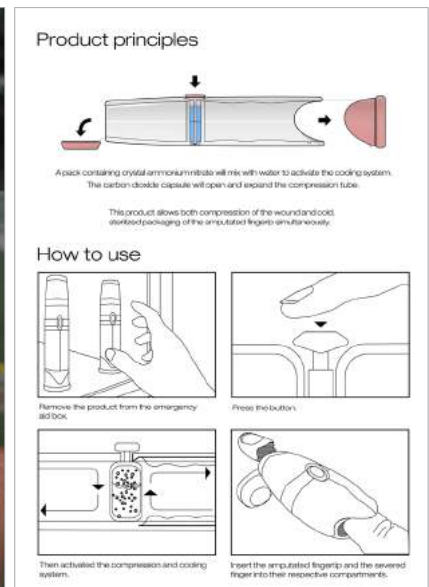





### Connecto

作者姓名 Name of Designer(s)  
Nilushi Sithara Fernando

指導老師 Instructor(s)  
無  
None

學校所在地 Location of School  
斯里蘭卡  
Sri Lanka

學校名稱 Name of School  
莫拉圖瓦大學  
University of Moratuwa

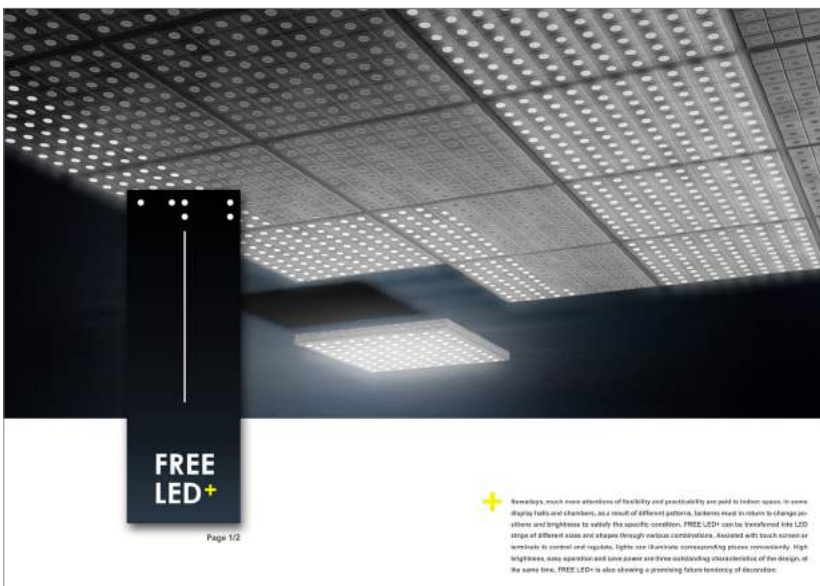

### 隨心 LED Free Led+

作者姓名 Name of Designer(s)  
田星宇、韓越、楊兆楠、吳越  
Xing-Yu Tian, Yue Han, Zhao-Nan Yang, Yue Wu

指導老師 Instructor(s)  
辛向陽  
Xiang-Yang Xin

學校所在地 Location of School  
中國大陸  
China

學校名稱 Name of School  
江南大學  
Jiangnan University



### Tiny Egg

作者姓名 Name of Designer(s)  
霍賜健  
Chi-Kin Fok

指導老師 Instructor(s)  
馮志強  
Chi-Keung Fung

學校所在地 Location of School  
香港  
Hong Kong

學校名稱 Name of School  
香港知專設計學院  
Hong Kong Design Institute

兩端用橡皮

Use Rubber at Both Ends

作者姓名 Name of Designer(s)

楊洋、郝雨菲、李霓裳、楊年、安國成

Yang Yang, Yu-Fei Hao, Ni-Shang Li, Nian Yang, Guo-Cheng An

指導老師 Instructor(s)

王龍

Long Wang

學校所在地 Location of School

中國大陸

China

學校名稱 Name of School

長沙理工大學

Changsha University of Science & Technology



鎖好了沒

I Key

作者姓名 Name of Designer(s)

許家齊

Chia-Chi Sheu

指導老師 Instructor(s)

無

None

學校所在地 Location of School

臺灣

Taiwan

學校名稱 Name of School

實踐大學

Shih Chien University



不粘刀

Non-Stick Knife

作者姓名 Name of Designer(s)

張沙、周才致

Theo Zhang, Cai-Zhi Zhou

指導老師 Instructor(s)

姚湘

Xiang Yao

學校所在地 Location of School

中國大陸

China

學校名稱 Name of School

湘潭大學

Xiangtan University



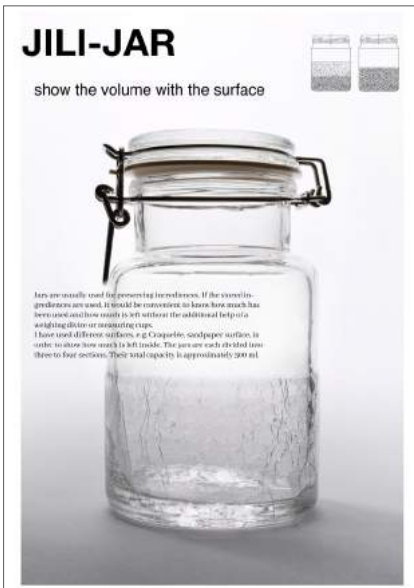

肌理刻度儲物罐

Jili-Jar

作者姓名 Name of Designer(s)

朱倩玉

Qian-Yu Zhu

指導老師 Instructor(s)

Barbara Schmidt, Peter Kuchinke

學校所在地 Location of School

德國

Germany

學校名稱 Name of School

柏林白湖藝術學院

Weissensee Academy of Art Berlin



Plier 屏風桌

Plier

作者姓名 Name of Designer(s)

黃懷惠

Lin-Huei Hwang

指導老師 Instructor(s)

孫崇實

Chung-Shih Sun

學校所在地 Location of School

臺灣

Taiwan

學校名稱 Name of School

實踐大學

Shih Chien University



Stack Shelf Thorsten

作者姓名 Name of Designer(s)

Till Strohmeier,

Theresa von Bodelschwing

指導老師 Instructor(s)

無

None

學校所在地 Location of School

德國

Germany

學校名稱 Name of School

明斯特設計學院

Akademie fuer Gestaltung Muenster



## Senik-Fire Extinguisher Redesign

作者姓名 Name of Designer(s)  
Sailee Adhao  
指導老師 Instructor(s)  
Vikram Parmar  
學校所在地 Location of School  
印度  
India  
學校名稱 Name of School  
國立設計學院 (艾哈邁達巴德)  
National Institute of Design, Ahmedabad



## 旋轉屏風 Folding Screen

作者姓名 Name of Designer(s)  
梁晨  
Chen Liang  
指導老師 Instructor(s)  
Glen Oliver Löw  
學校所在地 Location of School  
德國  
Germany  
學校名稱 Name of School  
漢堡美術學院  
University of Fine Arts of Hamburg



## Saitens

作者姓名 Name of Designer(s)  
Clara Schweers  
指導老師 Instructor(s)  
Erik Schneider  
學校所在地 Location of School  
德國  
Germany  
學校名稱 Name of School  
普爾茨海姆應用技術大學  
Pforzheim University of Applied Sciences



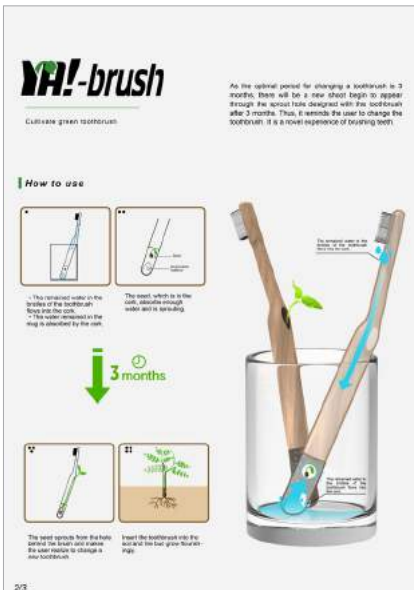

芽刷  
Ya-Brush

作者姓名 Name of Designer(s)  
郭沛城、呂君毅  
Pei-Cheng Guo, Jun-Yi Lv  
指導老師 Instructor(s)  
無  
None  
學校所在地 Location of School  
中國大陸  
China  
學校名稱 Name of School  
江南大學  
Jiangnan University



收缩式路锥设计  
Contracting Cone

作者姓名 Name of Designer(s)  
葉開成  
Kai-Cheng Ye  
指導老師 Instructor(s)  
湯軍  
Jun Tang  
學校所在地 Location of School  
中國大陸  
China  
學校名稱 Name of School  
武漢理工大學  
Wuhan University of Technology



Puzzle Stretcher

作者姓名 Name of Designer(s)  
Ye Sang Hyeok, Kang Ji Yeon  
指導老師 Instructor(s)  
無  
None  
學校所在地 Location of School  
韓國  
Korea  
學校名稱 Name of School  
昌原國立大學  
Changwon National University

沙寶 Sandbo

作者姓名 Name of Designer(s)  
吳珮喧  
Pei-Xuan Wu

指導老師 Instructor(s)  
陳禧冠  
Shi-Kuan Chen

學校所在地 Location of School  
臺灣  
Taiwan

學校名稱 Name of School  
實踐大學  
Shih Chien University



模組化泳圈 Modular Swimming Laps

作者姓名 Name of Designer(s)  
孫宇雯、張夢博、葉蕊、侯得林  
Yu-Wen Sun, Meng-Bo Zhang,  
Rui Ye, De-Lin Hou

指導老師 Instructor(s)  
包海獸、許坤、喬松  
Hai-Mo Bao, Kun Xu, Song Qiao

學校所在地 Location of School  
中國大陸  
China

學校名稱 Name of School  
大連民族大學  
Dalian Nationalities University

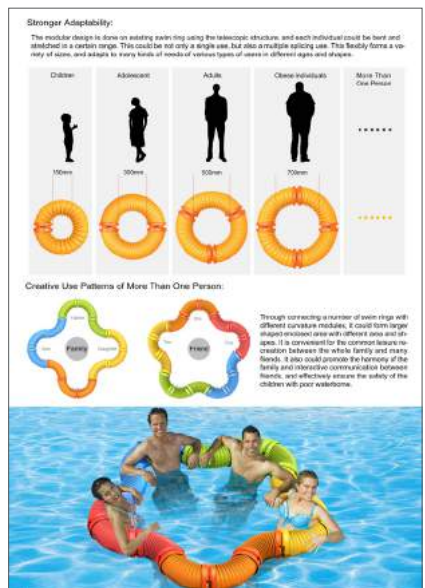

易取 A4 紙袋 Easy Bag

作者姓名 Name of Designer(s)  
徐悅、曹馨予、張孟博、王燕文  
Yue Xu, Xin-Yu Cao, Meng-Bo Zhang,  
Yan-Wen Wang

指導老師 Instructor(s)  
包海獸、許坤、喬松  
Hai-Mo Bao, Kun Xu, Song Qiao

學校所在地 Location of School  
中國大陸  
China

學校名稱 Name of School  
大連民族大學  
Dalian Nationalities University

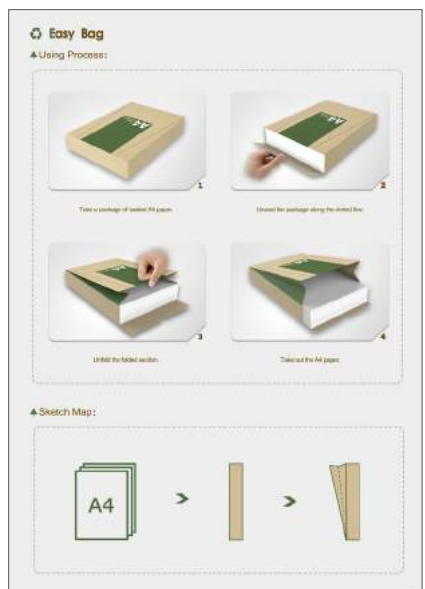



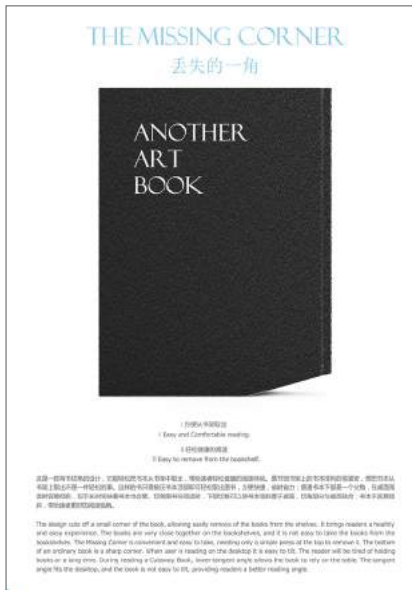

丢失的一角  
The Missing Corner

作者姓名 Name of Designer(s)  
葉蕊、張超軍、王舒煜、王狄  
Rui Ye, Chao-Jun Zhang,  
Shu-Yu Wang, Di Wang

指導老師 Instructor(s)  
包海默、喬松、許坤  
Hai-Mo Bao, Song Qiao, Kun Xu

學校所在地 Location of School  
中國大陸  
China

學校名稱 Name of School  
大連民族大學  
Dalian Nationalities University

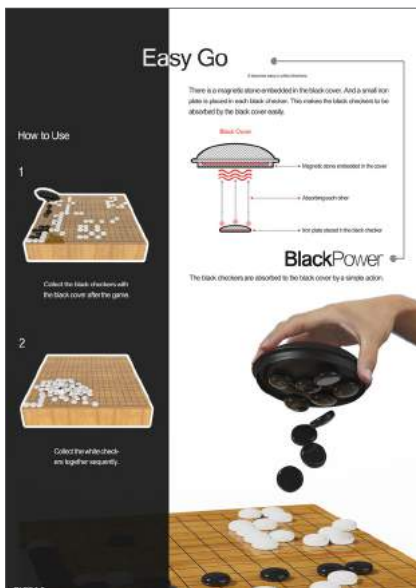

易收棋罐  
Easy Go

作者姓名 Name of Designer(s)  
于詩純  
Shi-Chun Yu

指導老師 Instructor(s)  
包海默、許坤、喬松  
Hai-Mo Bao, Kun Xu, Song Qiao

學校所在地 Location of School  
中國大陸  
China

學校名稱 Name of School  
大連民族大學  
Dalian Nationalities University

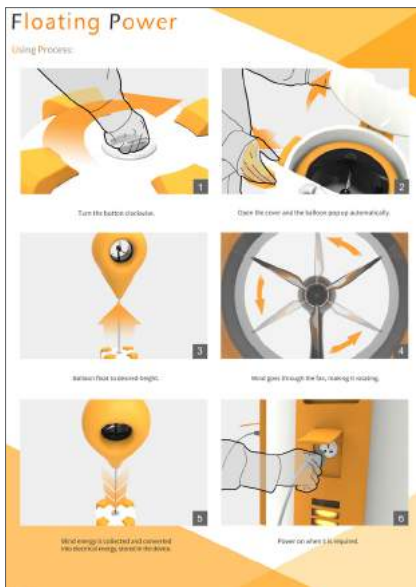

懸浮電源  
Floating Power

作者姓名 Name of Designer(s)  
何晉、于詩純、馬磊、宋佳霖  
Jin He, Shi-Chun Yu, Lei Ma,  
Jia-Lin Song

指導老師 Instructor(s)  
包海默、喬松、許坤  
Hai-Mo Bao, Song Qiao, Kun Xu

學校所在地 Location of School  
中國大陸  
China

學校名稱 Name of School  
大連民族大學  
Dalian Nationalities University

學齡前兒童成長型單車

Gro-up Bike

作者姓名 Name of Designer(s)

黃斯維、詹詔博

Sih-Wei Huang, Zhao-Bo Zhan

指導老師 Instructor(s)

黃信夫

Hsin-Fu Huang

學校所在地 Location of School

臺灣

Taiwan

學校名稱 Name of School

國立雲林科技大學

National Yunlin University of Science and

Technology



擔架椅

Stretcher Bench

作者姓名 Name of Designer(s)

楊斯宇

Sy-Yeu Yang

指導老師 Instructor(s)

陳榮煌、陳劭農

Rong-Huang Chen, Shao-Nong Chen

學校所在地 Location of School

臺灣

Taiwan

學校名稱 Name of School

國立成功大學

National Cheng Kung University

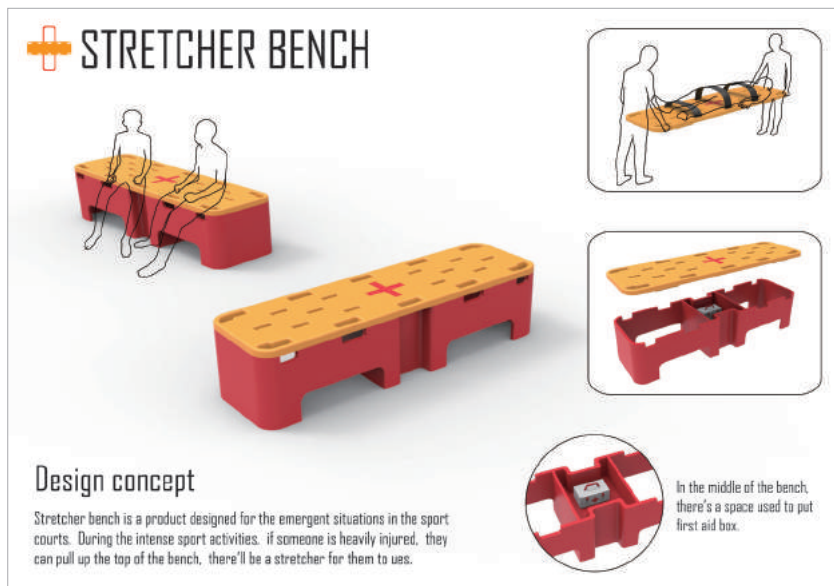

20 Minutes

作者姓名 Name of Designer(s)

沈亞麗

Ya-Li Shen

指導老師 Instructor(s)

孫許方

Xu-Fang Sun

學校所在地 Location of School

中國大陸

China

學校名稱 Name of School

中原工學院

Zhongyuan University of Technology



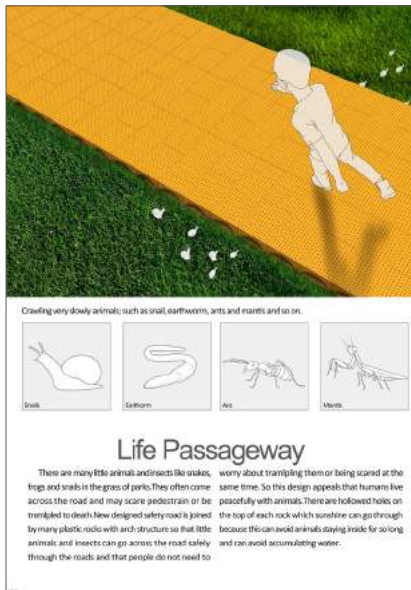
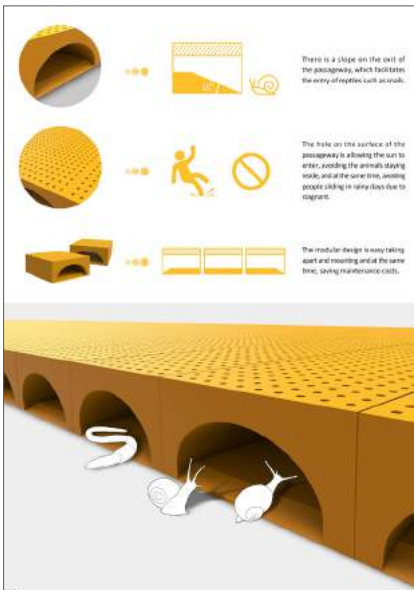

生命通道  
Life Passageway

作者姓名 Name of Designer(s)  
曾龍寶、陳展超、劉桂江、周紅超、楊金輝、涂添軍、林顯傑  
Long-Bao Zeng, Zhan-Chao Chen, Gui-Jiang Liu, Hong-Chao Zhou, Jin-Hui Yang, Tian-Jun Tu, Xian-Jie Lin

指導老師 Instructor(s)  
劉翔、鄺莉  
Xiang Liu, Li Yan

學校所在地 Location of School  
中國大陸  
China

學校名稱 Name of School  
廣東技術師範學院  
Guangdong Polytechnic Normal University

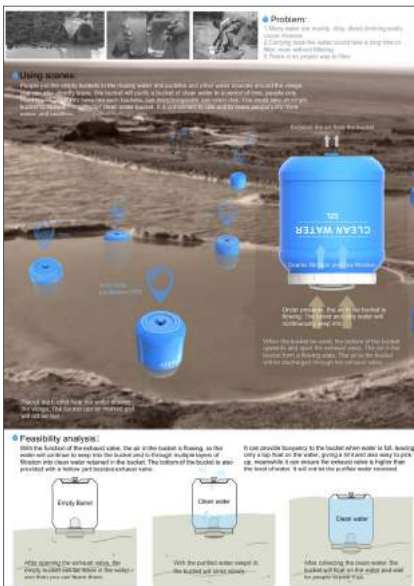

一天  
One Day

作者姓名 Name of Designer(s)  
徐文鑫、歐陽雪欣、王子健  
Wen-Xin Xu, Xue-Xin Ouyang, Zi-jian Wang

指導老師 Instructor(s)  
湯軍、李翔  
Jun Tang, Xiang Li

學校所在地 Location of School  
中國大陸  
China

學校名稱 Name of School  
武漢理工大學  
Wuhan University of Technology



Cap Sterilizer

作者姓名 Name of Designer(s)  
Seung-Hyun Choi

指導老師 Instructor(s)  
無  
None

學校所在地 Location of School  
韓國  
Korea

學校名稱 Name of School  
東西大學  
Dongseo University



## Watercycle Relief

作者姓名 Name of Designer(s)

Himadri Patel, Ashwathy CS

指導老師 Instructor(s)

無

None

學校所在地 Location of School

印度

India

學校名稱 Name of School

國立設計學院

National Institute of Design

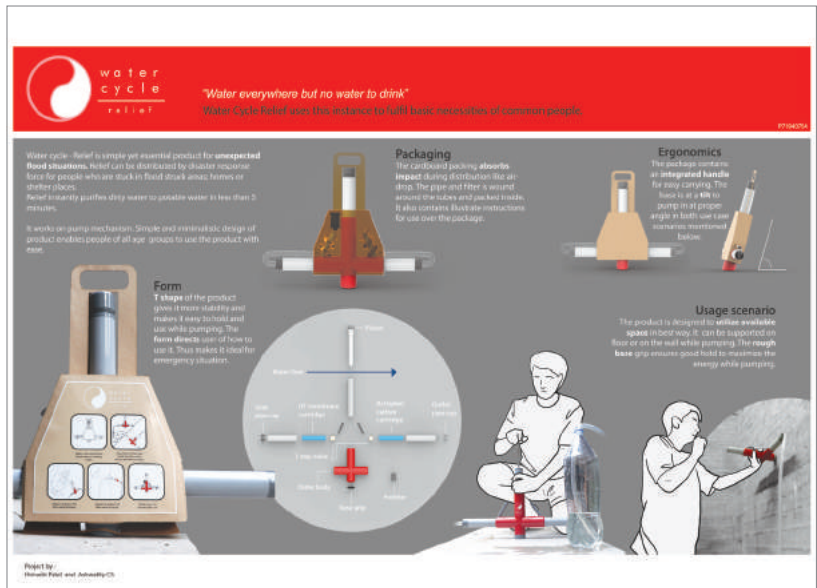

## 懸液

### Suspension

作者姓名 Name of Designer(s)

莫一駿、Philippine de Saint Aurin

Yi-Jun Mo, Philippine de Saint Aurin

指導老師 Instructor(s)

無

None

學校所在地 Location of School

法國

French

學校名稱 Name of School

卡蒙多學院

Architecture Intérieure A Camondo

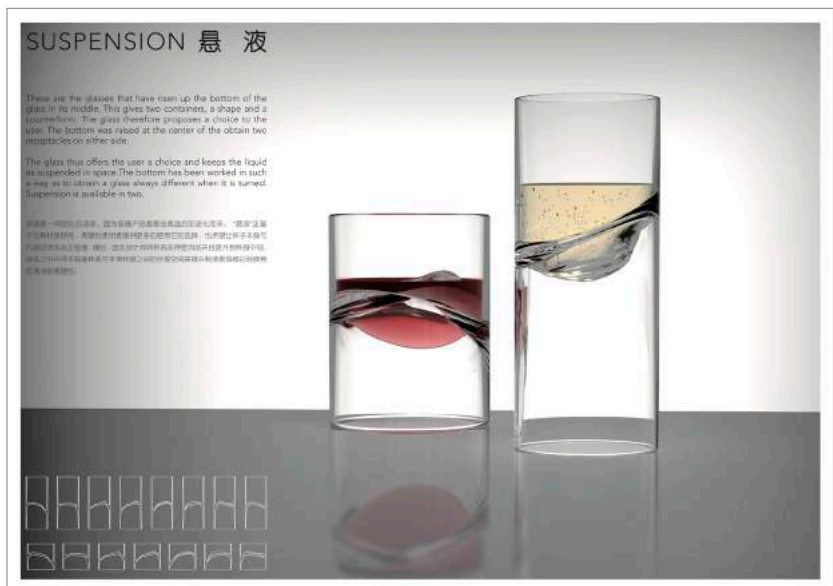

## 托盤存錢罐

### Tray Saving Pot

作者姓名 Name of Designer(s)

麥培珊

Pei-Shan Mai

指導老師 Instructor(s)

張劍

Jian Zhang

學校所在地 Location of School

中國大陸

China

學校名稱 Name of School

廣州美術學院

Guangzhou Academy of Fine Arts



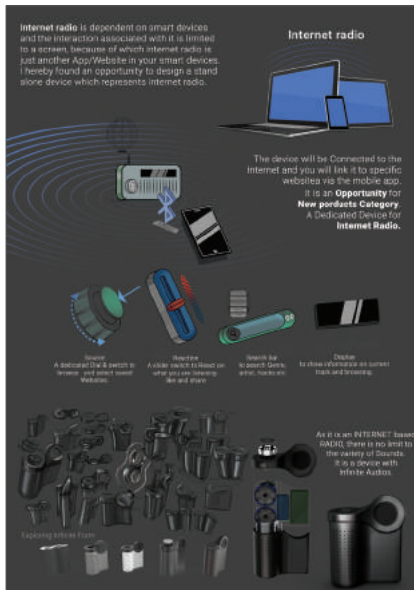

**Audioinfinity**

作者姓名 Name of Designer(s)

Abhishkek Yenji

指導老師 Instructor(s)

Abhishkek Yenji

學校所在地 Location of School

印度

India

學校名稱 Name of School

DSK 國際設計學院

DSK International School of Design



**Design for Mobility**

作者姓名 Name of Designer(s)

Camila Arias, Regina Serpas, Fátima Safie, Sofía Munés, Gerardo Murcia, Gabriel Tusell, Teresa Morán, Kevin Sibrian

指導老師 Instructor(s)

Eugenio Menjivar

學校所在地 Location of School

薩爾瓦多

El Salvador

學校名稱 Name of School

Monica Herrera 傳播學院

School of Communication Mónica Herrera

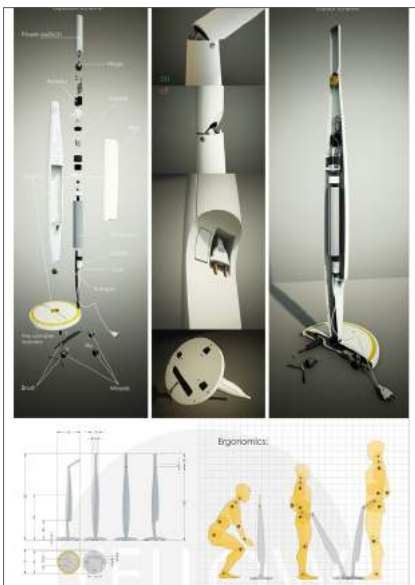

**Vertical Vacuum Cleaner**

作者姓名 Name of Designer(s)

Egor Oralin

指導老師 Instructor(s)

無

None

學校所在地 Location of School

白俄羅斯

Belarus

學校名稱 Name of School

白俄羅斯藝術學院

Belarusian State Academy of Arts

### Timer Cap

作者姓名 Name of Designer(s)  
 Jin Won Heo  
 指導老師 Instructor(s)  
 無  
 None  
 學校所在地 Location of School  
 韓國  
 Korea  
 學校名稱 Name of School  
 弘益大學國際高級研究設計學院  
 International Design School for Advanced Studies

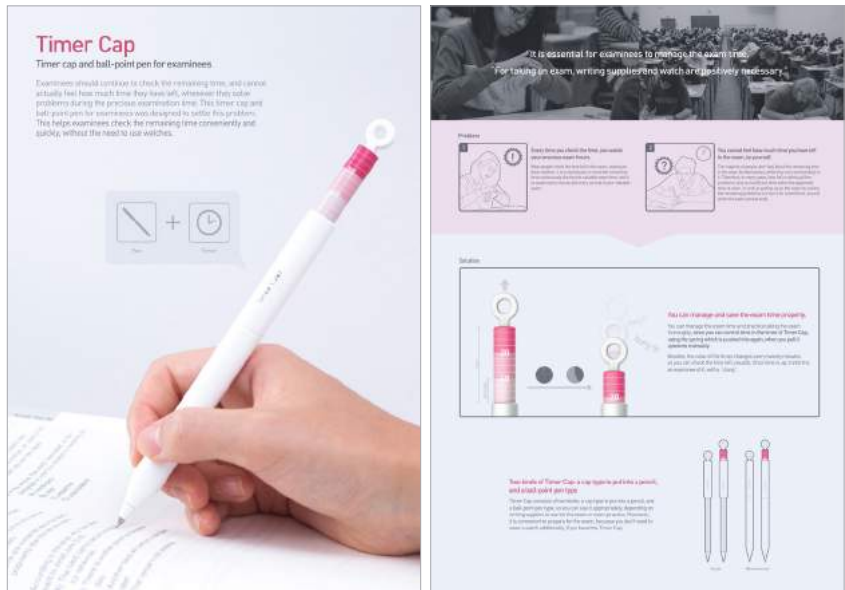

### Marine Cotton- Factories Based on Water Technologies

作者姓名 Name of Designer(s)  
 Melanie Glöckler  
 指導老師 Instructor(s)  
 Mareike Gast  
 學校所在地 Location of School  
 德國  
 Germany  
 學校名稱 Name of School  
 哈勒藝術大學  
 Burg Giebichenstein University of Art and Design Halle



### Signal License Plate

作者姓名 Name of Designer(s)  
 Jin Won Heo  
 指導老師 Instructor(s)  
 無  
 None  
 學校所在地 Location of School  
 韓國  
 Korea  
 學校名稱 Name of School  
 弘益大學國際高級研究設計學院  
 International Design School for Advanced Studies





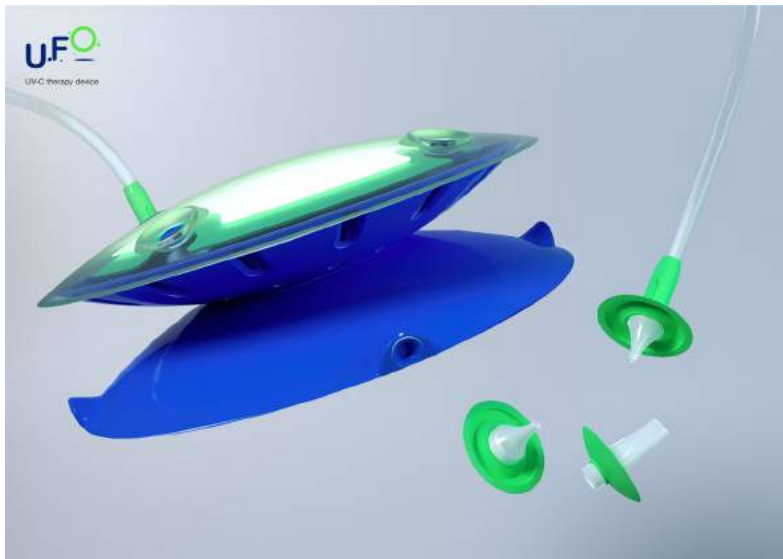

### UFO UV-Therapy Device

作者姓名 Name of Designer(s)

Anna Lychagina

指導老師 Instructor(s)

Victor Bragin

學校所在地 Location of School

俄羅斯

Russia

學校名稱 Name of School

烏拉爾建築藝術學院

Ural State University of Architecture and Art

Russia



### 希望之光

### The Light of Hope

作者姓名 Name of Designer(s)

劉一君

Yi-Jun Liu

指導老師 Instructor(s)

無

None

學校所在地 Location of School

中國大陸

China

學校名稱 Name of School

西安工業大學

Xi'an Technological University



### Waive. Hair & Hand Dryer

作者姓名 Name of Designer(s)

Sewon Chung, Hyunyoung Cho, Jonghun Lee, Hyunmyung Lee, Hyunsu Park, Jaewan Choi

指導老師 Instructor(s)

無

None

學校所在地 Location of School

韓國

Korea

學校名稱 Name of School

弘益大學

Hongik University

### Plate In. Plate Type Induction

作者姓名 Name of Designer(s)  
 Sewon Chung, Hyunmyung Lee,  
 Hyunyong Cho, Jonghun Lee,  
 Hyunsu Park, Jaewan Choi

指導老師 Instructor(s)  
 無  
 None

學校所在地 Location of School  
 韓國  
 Korea

學校名稱 Name of School  
 弘益大學  
 Hongik University



### 視覺迷思 Myth of Vision

作者姓名 Name of Designer(s)  
 楊葉  
 Ye Yang

指導老師 Instructor(s)  
 無  
 None

學校所在地 Location of School  
 英國  
 United Kingdom

學校名稱 Name of School  
 伯明罕藝術設計學院  
 Birmingham Institute of Art and Design



### Aligno

作者姓名 Name of Designer(s)  
 Karthik P B

指導老師 Instructor(s)  
 Koumudi Patil

學校所在地 Location of School  
 印度  
 India

學校名稱 Name of School  
 印度理工學院 (坎普爾)  
 Indian Institute of Technology, Kanpur



## Aligno

### What is Aligno?

Aligno is a multi-layered physical map which allows users to quickly search buildings/ locations and navigate easily. This map is of a college campus which was designed as part of student project. The campus area is approximately 0.6 sq. km. Faculty and students mostly walk in the campus.

### How to use Aligno?

To begin with, user must know his destination. If you know that, the task from there on is fairly simple. Rotate the bottom layer such that your location aligns to the pointer of FROM box. Then, rotate the middle layer to align your destination to the pointer of the TO box. And voila! A green circle and a red circle on the map will direct you between the From and To places.

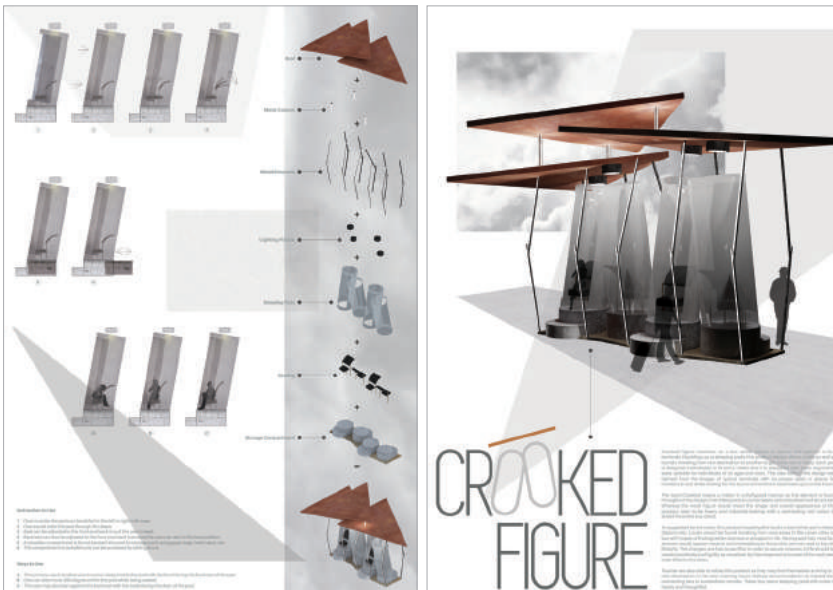

### Crooked Figure

作者姓名 Name of Designer(s)

Huei Nian Loh

指導老師 Instructor(s)

Jason Toh Ah Pook, Tan Zen Lin

學校所在地 Location of School

馬來西亞

Malaysia

學校名稱 Name of School

吉隆坡萊佛士高等學院

Raffles College of Higher Education Kuala Lumpur



### 運動水袋

#### Sports Water Bag

作者姓名 Name of Designer(s)

趙亞輝、孫赫陽、張廣欣

Ya-Hui Zhao, He-Yang Sun,

Guang-Xin Zhang

指導老師 Instructor(s)

無

None

學校所在地 Location of School

中國大陸

China

學校名稱 Name of School

西安工業大學

Xi'an Technological University

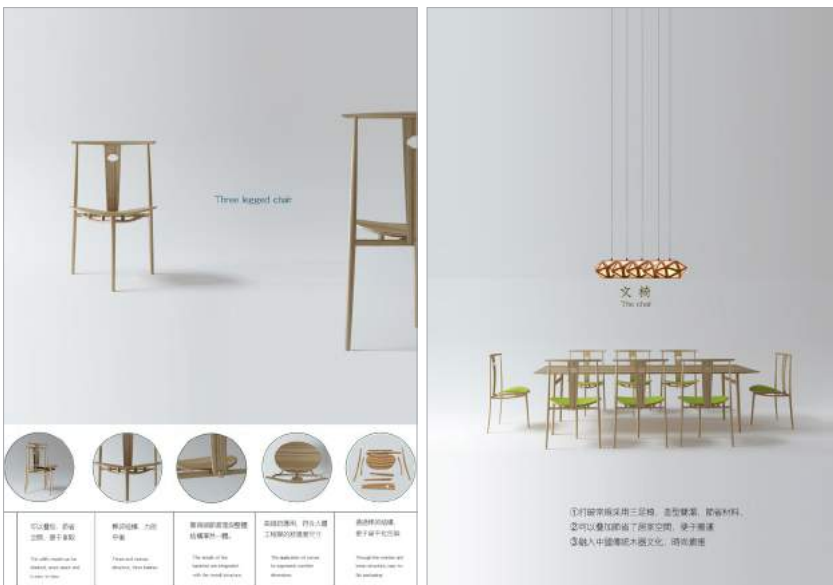

### 文椅

#### The Chair

作者姓名 Name of Designer(s)

翟偉民、徐樂、林幸民

Wei-Min Zhai, Le Xu, Xing-Min Lin

指導老師 Instructor(s)

無

None

學校所在地 Location of School

中國大陸

China

學校名稱 Name of School

東北林業大學

Northeast Forestry University



## 溫柔的聲音 Gentle Voice

作者姓名 Name of Designer(s)  
李博學、李夢雪  
Bo-Xue Li, Meng-Xue Li

指導老師 Instructor(s)  
劉雪飛、方迪  
Xu-Fei Liu, Di Fang

學校所在地 Location of School  
中國大陸  
China

學校名稱 Name of School  
大連民族大學  
Dalian Nationalities University



## Allay

作者姓名 Name of Designer(s)  
Bhavika Vajani

指導老師 Instructor(s)  
Shimul Mehta Vyas

學校所在地 Location of School  
印度  
India

學校名稱 Name of School  
國立設計學院  
National Institute of Design



## Illume Lighting

作者姓名 Name of Designer(s)  
Asish Mohandas

指導老師 Instructor(s)  
無

None

學校所在地 Location of School  
印度  
India

學校名稱 Name of School  
印度理工學院 (坎普爾)  
Indian Institute of Technology, Kanpur



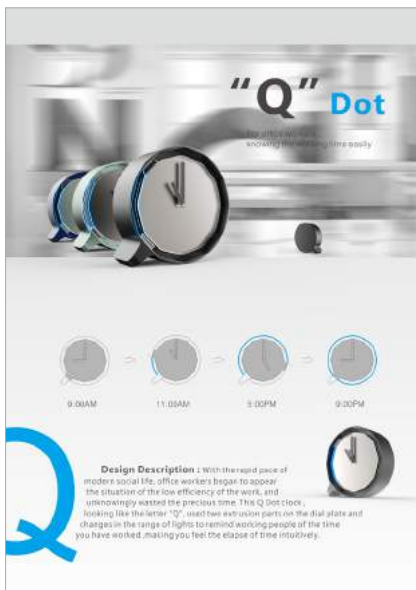

## "Q" Dot 工作時鐘

### "Q" Dot

作者姓名 Name of Designer(s)

劉燕萍

Yan-Ping Liu

指導老師 Instructor(s)

張成

Isabel Zhang

學校所在地 Location of School

中國大陸

China

學校名稱 Name of School

華僑大學

Huaqiao University

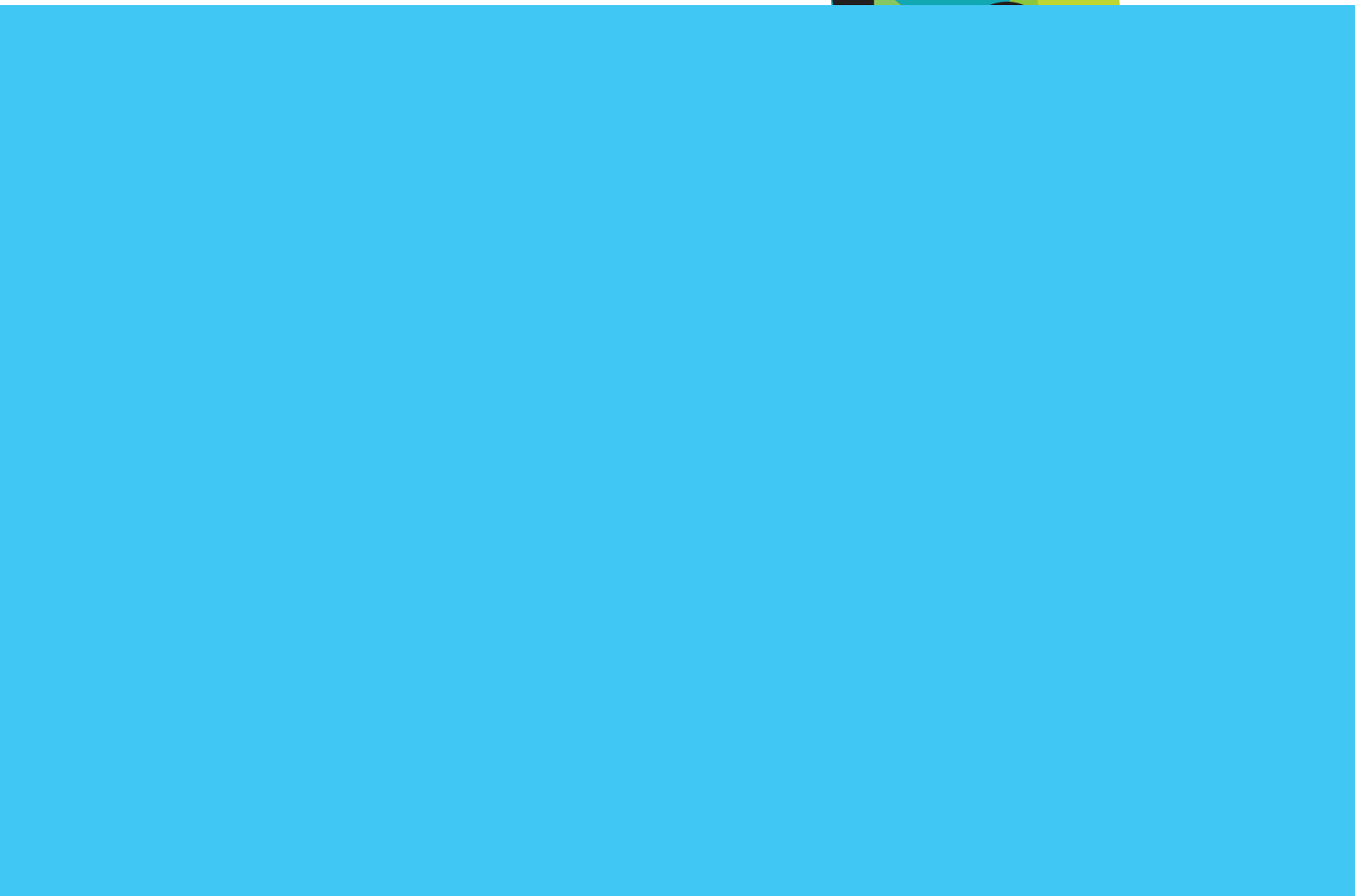





2017

# Opportunity

視覺設計類得獎作品

Winners of Visual Design Category

## 金獎作品評審講評 Jury Comments on Gold Prize

### Mehdi Saeedi

伊朗 Iran

事實上，我投下金獎的海報作品形式非常強，同時又很簡單。設計師試著利用中文漢字創造出強而有力的形式，而且中文字與牆面的插畫擁有非常好的連結。雖然我並不懂中文，但我還是接收到了視覺所傳達的語言。

Actually, the poster that I voted for as the gold medal winner has a strong form and is simple. The designer tried to use mandarin Chinese characters for creating a strong form, and also the Chinese characters have a very good connection with the illustration of the walls. Although I don't understand Chinese, but I got language of visual communication.

### Pavel Noga

捷克 Czech Republic

在評選過程中，金銀獎兩者在我看來，主要的差別是在細節的部份。我身為一個歐洲人，中文字對我來說即像是一張圖畫，不過金獎作品除了文字之外還包含許多深厚的中華文化意涵，此作品真正的價值所在是希冀透過圖像形式海報，完整的呈現華文文化特色，讓外國觀者能藉此作品更深入的了解和探究華文文化。

During the process of selection, the main difference between the gold prize and silver prize works to me was in their details. I am European, so Chinese characters to me are exactly like images. But in addition to the language, the gold prize winning entry contains deeper meaning regarding Chinese culture. The true value of this entry lies in the fact that it hopes to use imagery and form on the posters to thoroughly display the features of Chinese culture so that foreign watchers can better understand and explore it through this work.





字蹟

Finding Taiwan Old Street\_ Three Scenic Views of Lukang

作者姓名 Name of Designer(s)  
黃聖軒、吳承諭  
Sheng-Syuan Huang, Cheng-Yu Wu

指導老師 Instructor(s)  
游明龍  
Ming-Lung Yu

學校所在地 Location of School  
臺灣  
Taiwan

學校名稱 Name of School  
亞洲大學  
Asia University



作品說明 Project Description

在早期「半邊井」的設計，是為了供給沒有能力鑿井的人汲水取用。蜿蜒的「九曲巷」則為防盜賊侵入，並防止九降風肆虐，因此將巷道築成迂迴曲折狀。而在巷弄間的樓橋「十宜樓」，則是昔日文人雅士吟風弄月、品茗吟詠之所。藉由鹿港當地三大景點的圖像，結合漢字的筆畫做出巧妙的排列組合，讓觀者見古蹟，思情意，悠遊在漢字與古蹟之間，欣賞傳統之美。

Follow our posters to find Taiwan old street-three scenic views of Lukang, like Half-sided Well, Nine-turn Lane, Shih-Yih Hall. Hope you can find the interesting combination between graphic and traditional Chinese characters. For example, We combine Nine and turn, these two traditional Chinese words together, and add image of lane's graphic in Lukang to create this poster. Hope you can find the interesting in graphic and traditional Chinese characters, and know more about Lukang.





數說年齒

Title of Age in Ancient China

作者姓名 Name of Designer(s)

姚凱倫

Kai-Lun Yao

指導老師 Instructor(s)

韓緒、林俊良

Xu Han, Chun-Liang Lin

學校所在地 Location of School

中國大陸

China

學校名稱 Name of School

中國美術學院上海設計學院

Shanghai Institute of Design-China

Academy of Art



作品說明 Project Description

人的一生中，機遇隨著年齡而波動著。作品將古代年齡稱謂同與之對應的、現代常用的阿拉伯數字融合為一體，將縱向的歷史線與橫向的人生線結合，勸誡人們抓住亙古不變的年齡機遇、整合資源創造價值。

In the life of a person, the opportunity fluctuates with age. The works combined the title of age in ancient China with the corresponding, modern Arabic numerals commonly used. And also combined the vertical history line and horizontal life line, to persuade people to seize the everlasting age opportunities, integrate the resources to create value.

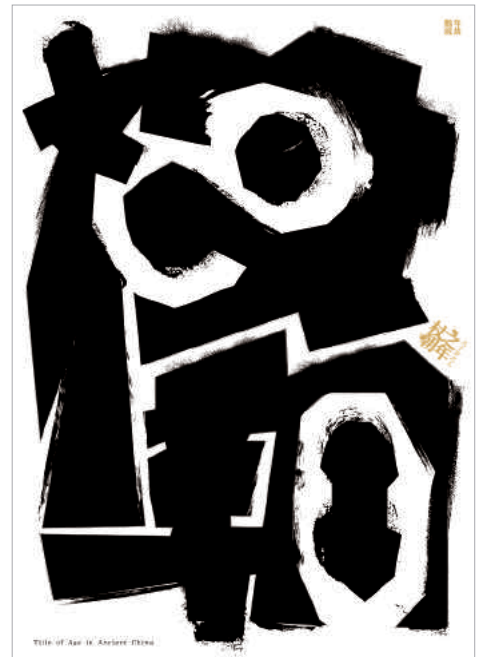
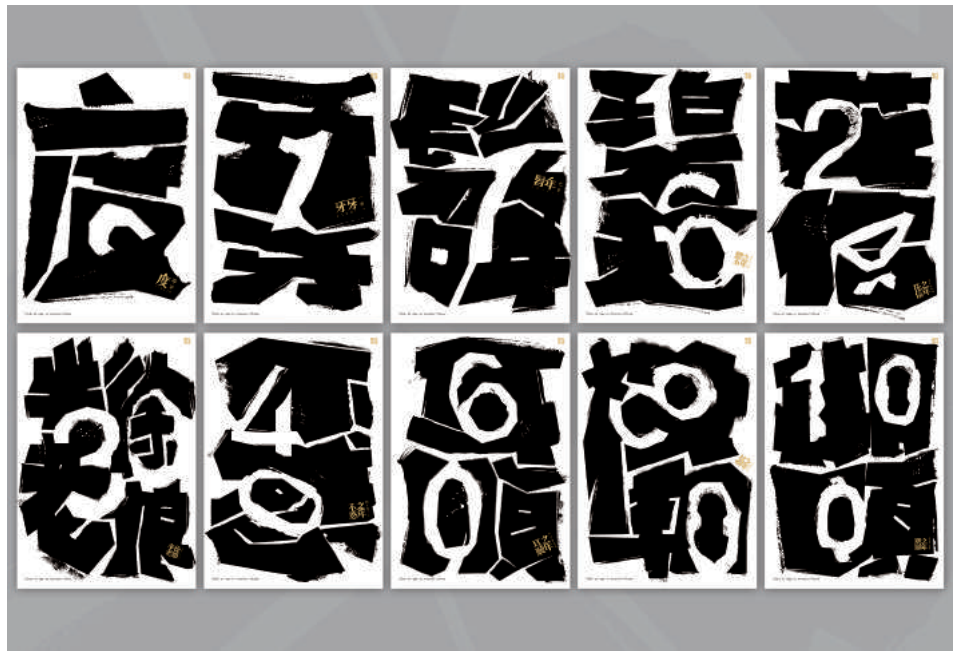

鄰居的耳朵線上音樂平臺一線  
下音樂會視覺設計

Neighbor's Ear Vision Design

作者姓名 Name of Designer(s)

朱天航

Tian-Hang Zhu

指導老師 Instructor(s)

姚翔宇

Xiang-Yu Yao

學校所在地 Location of School

中國大陸

China

學校名稱 Name of School

南京藝術學院

Nanjing University of the Arts



作品說明 Project Description

鄰居的耳朵是一個獨立美文與音樂交流平臺，因為老式的形象已經沒有辦法吸引年輕一代的消費人群了。基於這一事實情況，設計師靈感來源於閱讀時的眼睛與音符組成一個對稱式的logo，由此延伸出一套視覺形象。螢光色的運用是為了增加活力。海報的設計採用了抽象化的線條，鄰居的耳朵這幾個字蘊含其中，獨具匠心。

The neighbors' ears are an independent American and music platform, because the old-fashioned image has no way of attracting the younger generation of consumers. Based on this fact, the designer's inspiration comes from the fact that the eyes and notes are formed into a symmetrical logo, thereby extending a visual image. Fluorescent colors are used to increase energy. The design of the poster uses abstract lines, and the words of the neighbors' ears contain some kind of originality.

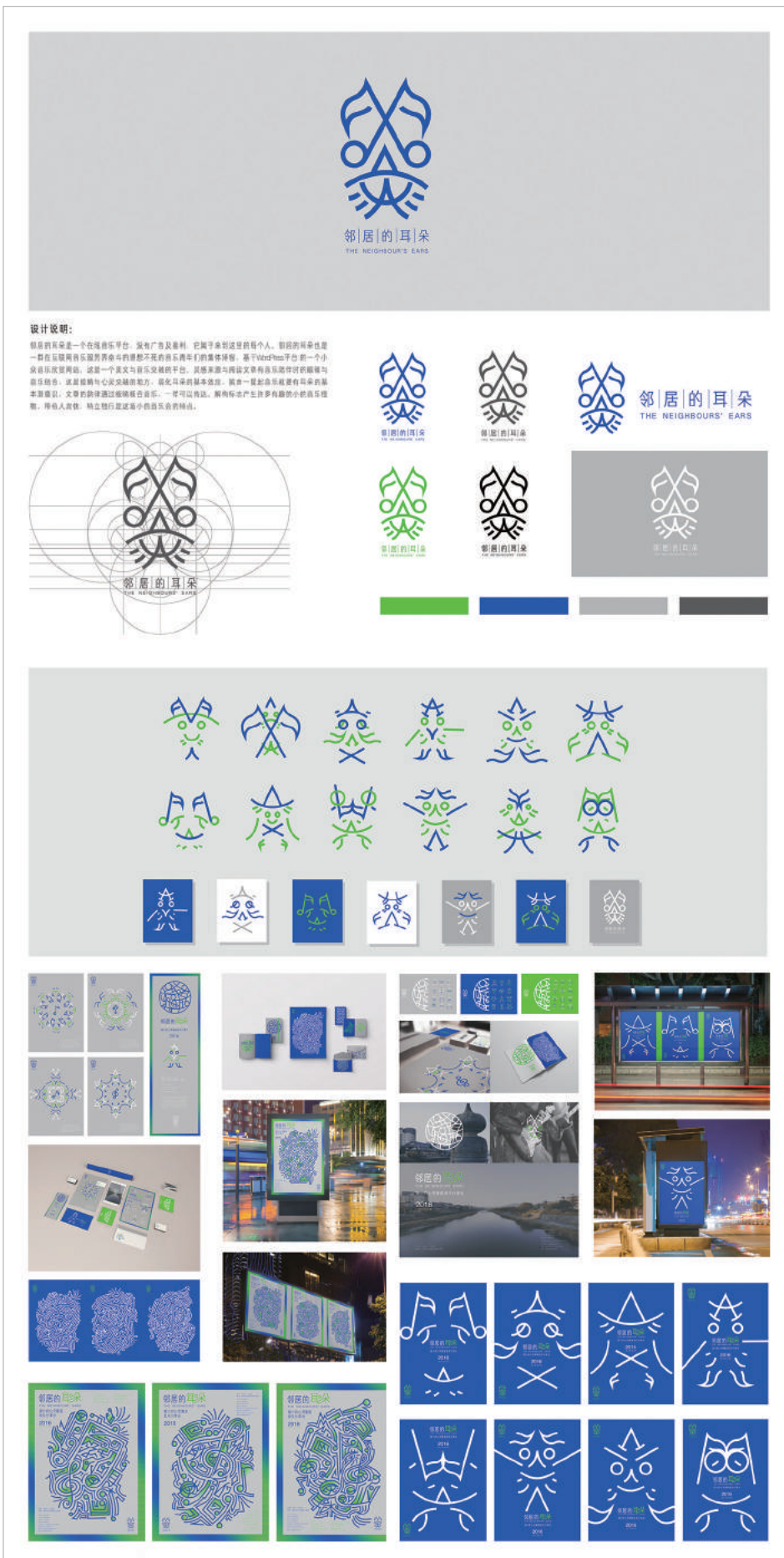



小日字  
Shiou Li Ji

作者姓名 Name of Designer(s)  
林俊均、楊采廷、楊雅筑  
Jie-Jun Lin, Tsai-Ting Yang, Ya-Chu Yang

指導老師 Instructor(s)  
蘇沛琪、童鼎鈞  
Pei-Chi Su, Ting-Chun Tung

學校所在地 Location of School  
臺灣  
Taiwan

學校名稱 Name of School  
南臺科技大學  
Southern Taiwan University of Science and Technology



作品說明 Project Description

還記得回憶裡，印刷油墨的味道與提筆執筆的感動嗎？從日常生活中取材，由生日密碼解析，為365個日子誕生專屬的「一字定義」，由此「每日字」去代表當日出生的你與存在意義。結合農曆「宜」、「忌」元素，提醒該天出生的人格須注意、宜精進。事項。並以傳統的缺角、油墨斑駁為元素，設計出擁有殘損、缺陷美之「小日字體」。透過日曆呈現，下方設計撕式便條，方便使用者書寫記錄。並於特殊節日運用不同的紙質；24節氣蓋上四季分色圓點作視覺區隔，以此傳遞逐漸被科技所淡忘的文字溫度、印刷觸感及油墨記憶。文字·日子·日誌·日子，就是我們的「小日字」。

As technology advances, we have gradually forgotten the origin of cultural continuity-temperature of the text and the taste of ink. Through the calendar, we defined for each day an exclusive The daily word to represent you born that day, and the meaning of existence to increasing links with the user and resonance. By using Chinese traditional print element about text corner and ink sense of nature damage as an element of design has beauty spot and dappled as our font design.

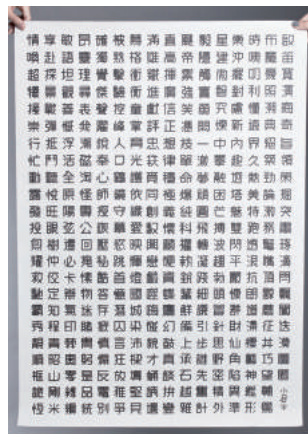





### 生機

#### Give Your Life a Chance

作者姓名 Name of Designer(s)

鄒云岱

Yun-Dai Zou

指導老師 Instructor(s)

游明龍

Ming-Lung Yu

學校所在地 Location of School

臺灣

Taiwan

學校名稱 Name of School

亞洲大學

Asia University



#### 作品說明 Project Description

防止自殺行為。希望幫助人們更加珍惜自己的生命。利用水上救生工具做結合，使每個自殺方式多了一層求生的機會。

Prevents the suicide behavior. Hope to help person treasure their life. Uses the aquatic life preserver to make the union, caused each suicide way many the opportunity which one sought livelihood.

## 言論自由

## Freedom of Speech

作者姓名 Name of Designer(s)

黃祖維

Chang-Wei Huang

指導老師 Instructor(s)

曾薰誼

Hsun-Yi Tseng

學校所在地 Location of School

臺灣

Taiwan

學校名稱 Name of School

崑山科技大學

Kun Shan University



## 作品說明 Project Description

「言」此字，不得再以張口伸舌的單純意象來運用至生活當中。在網路世代裡，不經意的文字與那有著自由標籤的言論，常常句句帶針，發送無經思考的訊息，對人的傷害層層影響至內心，當「言論自由」四字被惡意扭曲醜化，那社會、環境與人的連結，將會就此瓦解。

The word "speech" can no longer be applied in daily life as a simple image of opening one's mouth and putting out one's tongue. In the internet era, the unintended words and the speeches labeled freedom hurt people like needles. The messages sent without thinking are very harmful to people's hearts. When the words "freedom of speech" are distorted or defamed maliciously, the links among the society, environment and people may be dismantled.





### Typecon Identity

作者姓名 Name of Designer(s)

Jens Marklund

指導老師 Instructor(s)

Jon Newman

學校所在地 Location of School

美國

United States of America

學校名稱 Name of School

紐約視覺藝術學院

School of Visual Arts



### 作品說明 Project Description

透過最為標準化的字體 Helvetica Medium，接著再利用掃描器手動將字體進行拉伸，最後就能創造出比傳統字體更為活潑有機的成果。對於主辦一場會議的字體設計師而言，拉伸字體也是一件非常有娛樂感的事情，可以作為會議開場的破冰活動。

By taking the most standard typeface out there, Helvetica Medium, and stretching it by hand using a scanner-it can create a more organic result than traditional typography. Stretching type for a conference hosting typographers is also pretty hilarious. It makes for a good ice breaker.



保護女性軀體

Protect Female Body

作者姓名 Name of Designer(s)

陳彥霏

Yan-Fei Chen

指導老師 Instructor(s)

張文化、游明龍

Wen-Hua Zhang, Ming-Lung Yu

學校所在地 Location of School

中國大陸

China

學校名稱 Name of School

廈門大學

Xiamen University



作品說明 Project Description

女性是許多性侵害事件的受害者，雨傘是代表保護她們的軀體的物件，也象徵著社會對她們的愛護。

Women are the victims of many sexual assaults. Umbrellas represent objects that protect their bodies, as well as the love of society for them.

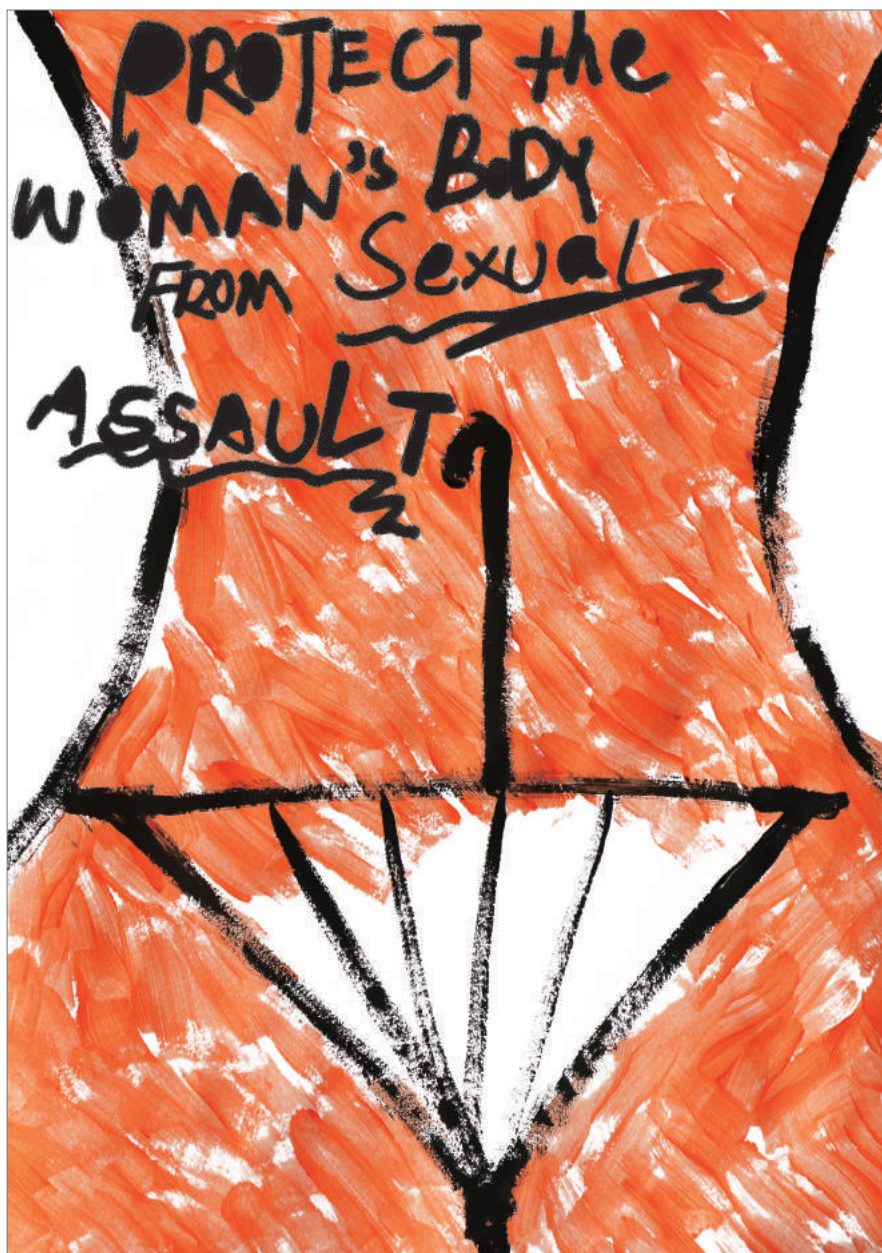





## Opportunity

作者姓名 Name of Designer(s)

李夢丹

Meng-Dan Lee

指導老師 Instructor(s)

李雙

Shuang Lee

學校所在地 Location of School

中國大陸

China

學校名稱 Name of School

福州大學廈門工藝美術學院

Xiamen Academy of Arts and Design,  
Fuzhou University



作品說明 Project Description

機會就在我們身邊的各個角落，時刻等待著我們去發現，只有不斷地努力嘗試，才能贏得更多機會，從而獲得勝利。機會總是留給敢於嘗試的人。

Opportunities are in every corner of us, waiting for us to find out that only by constantly trying can we win more opportunities and win. Opportunities are always for those who dare to try.

礫塵體

Gravel Dust

作者姓名 Name of Designer(s)

崔雄智  
Xiong-Zhi Cui

指導老師 Instructor(s)

吳軼博  
Yi-Bo Wu

學校所在地 Location of School

中國大陸  
China

學校名稱 Name of School

吉林藝術學院  
Jilin University of the Arts



作品說明 Project Description

礫塵體是以點為主要元素，通過點的大小與聚散來表現出字體筆劃的虛實，像微風吹過塵土一般若隱若現。

Gravel dust is based on the point as the main element, through the size of the point and gather together to show the actual situation of the font strokes, like breeze blowing dust looming.

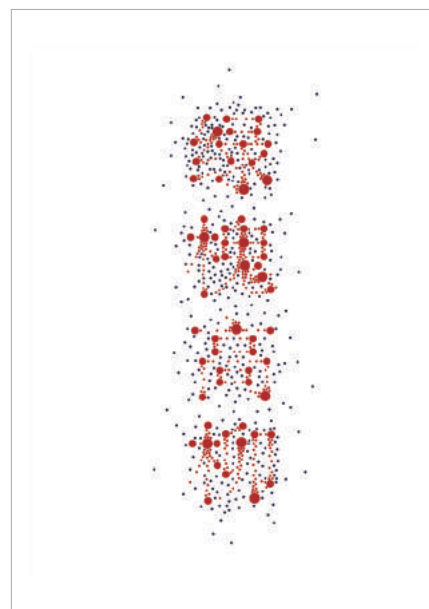
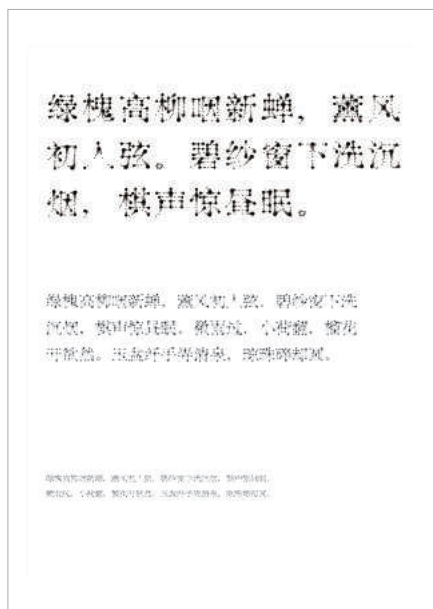
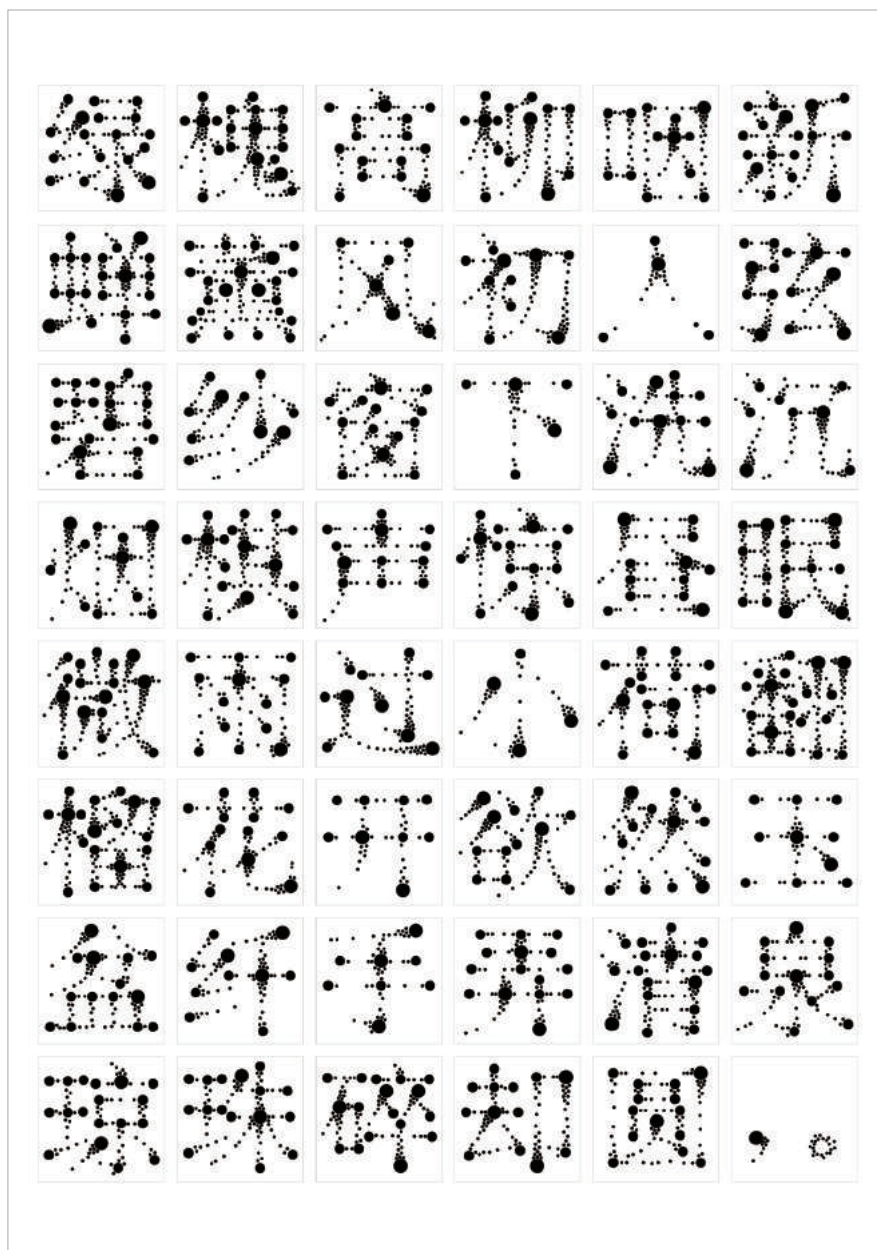





山水  
Landscape

作者姓名 Name of Designer(s)

林俊銘

Chun-Ming Lin

指導老師 Instructor(s)

陳冠勳

Kuan-Hsun Chen

學校所在地 Location of School

臺灣

Taiwan

學校名稱 Name of School

弘光科技大學

Hungkuang University



作品說明 Project Description

過度開發對人類和當地的植物群落與動物都會產生重大的負面影響，而世界雨林可能會以目前的砍伐速度在一百年內完全消失。

Clearcutting can have major negative impacts, both for humans and local flora and fauna. The world's rain forests could completely vanish in a hundred years at the current rate of deforestation.



## 石獅錄 - 金門風獅爺圖鑑 Kinmen Wind Lion God- Guide Book

作者姓名 Name of Designer(s)  
顏敬安、高在芹、楊芷綾、趙于婷  
Jing-An Yan, Zai-Cin Gao,  
Chin-Ling Yang, Yu-Ting Chao

指導老師 Instructor(s)  
張盛權  
Sheng-Chuan Chang

學校所在地 Location of School  
臺灣  
Taiwan

學校名稱 Name of School  
中國科技大學  
China University of Technology



### 作品說明 Project Description

一提到金門，多半人馬上會連想到風獅爺，風獅爺不僅是金門的代表，更是當地的守護者。金門每一個小村落都有專屬的風獅爺，他們的花紋和樣式都非常不同，各具特色。我們在蒐集其資料時，發現目前有不少專門介紹的部落格網站及學術研究類的書籍，但大多並不完整且缺乏系統性的視覺化。因此，我們決定製作圖鑑指南手冊，藉由視覺上的再包裝讓金門風獅爺呈現新的面貌與活力。這套圖鑑指南的內容物有：金門風獅爺圖鑑一本，絹印方巾及屋脊型風獅爺小冊。以絹印版畫的技法創作風獅爺的插圖，並藉由樸質的風格和動作呈獻出風獅爺更為活潑親近居民的一面。

When it comes to Kinmen, most people think about wind-lion, which is not only a symbol, but also a gurdian of Kinmen. Each village in Kinmen has it's own wind-lion, their patterns and carving styles are all distinctive. When we collected data, we found many specialized books and blogs introducing wind-lions, but they are not thorough enough and lack visualization. Therefore, we decided to make an illustrated book, showing people the vitality and new creative looks of Kinmen's wind-lions.



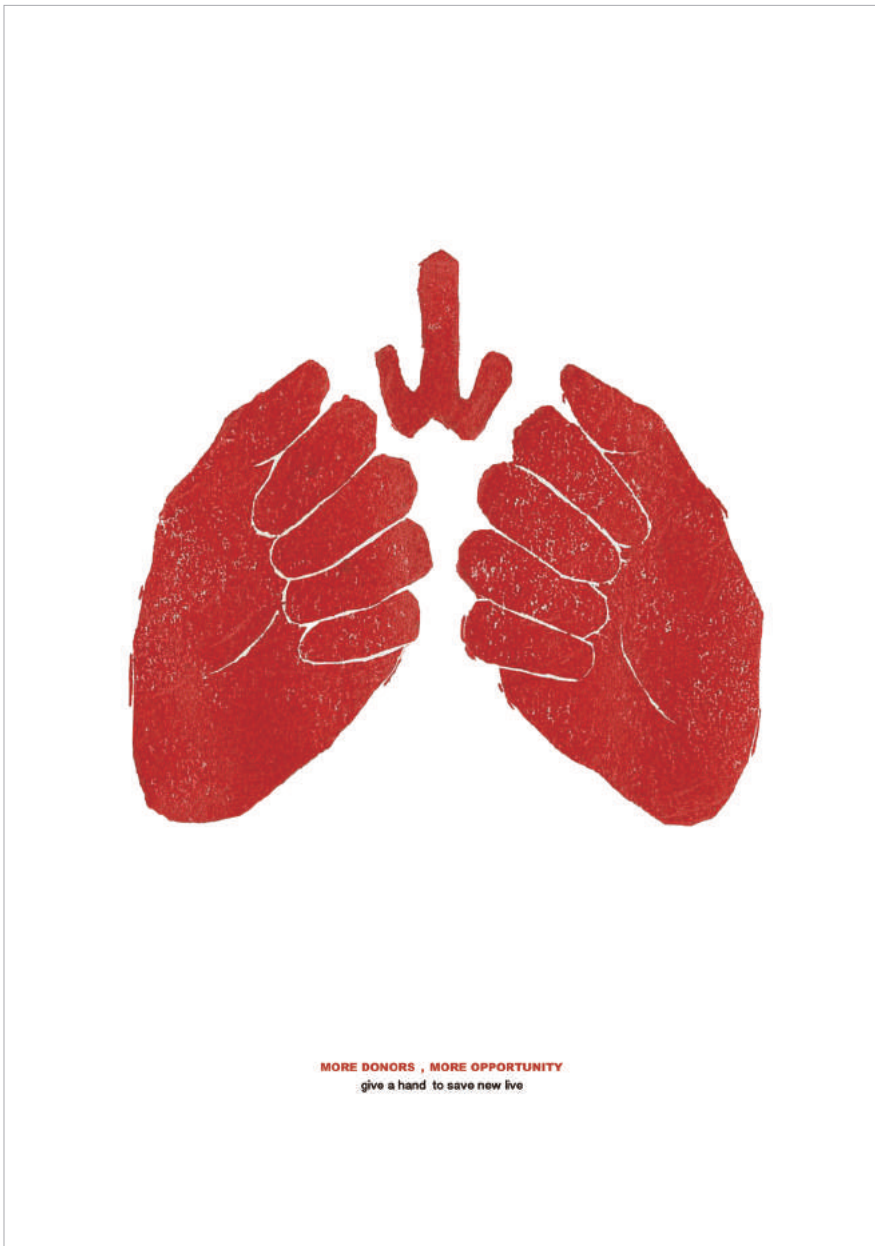

無  
**None**

作者姓名 Name of Designer(s)

吳雙

Shuang Wu

指導老師 Instructor(s)

李新富

Shin-Fu Lee

學校所在地 Location of School

臺灣

Taiwan

學校名稱 Name of School

亞洲大學

Asia University



作品說明 Project Description

利用手與手組成不同器官形狀如心臟，腎臟，肺。以此表達捐贈器官的生命傳遞。

The shape of the lungs, heart, and kidneys is formed by hands. To express the life transfer.





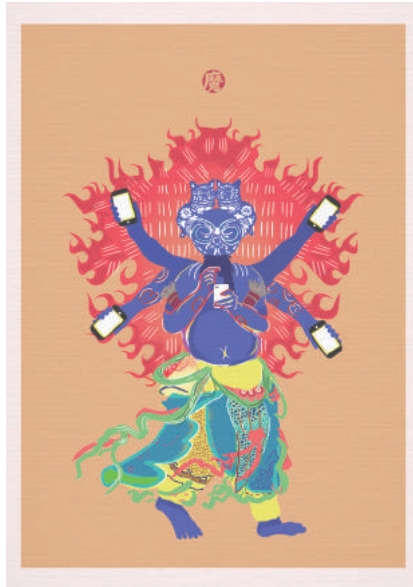

**妖魔新說**  
**New Story about Goblin and Demon**

作者姓名 Name of Designer(s)

楊博

Bo Yang

指導老師 Instructor(s)

劉春艷

Chun-Yun Liu

學校所在地 Location of School

中國大陸

China

學校名稱 Name of School

天津商業大學

Tianjin University of Commerce



**"糖村"牛紮糖品牌系列包裝**  
**Sugar & Spice Nougat Brand Series of Packaging**

作者姓名 Name of Designer(s)

楊博

Bo Yang

指導老師 Instructor(s)

李晗哲

Han-Zhe Li

學校所在地 Location of School

中國大陸

China

學校名稱 Name of School

天津商業大學

Tianjin University of Commerce

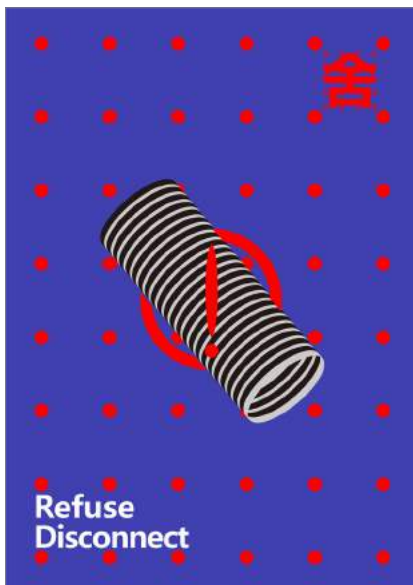

**斷捨離**  
**Abandon**

作者姓名 Name of Designer(s)

李伊晨

Yi-Chen Li

指導老師 Instructor(s)

郝鵬

Pen Hao

學校所在地 Location of School

中國大陸

China

學校名稱 Name of School

天津電子信息職業技術學院

Tianjin Electronic Information College

## 九個人的快遞

### Nine People Express Book Design

作者姓名 Name of Designer(s)

魏錦

Jin Wei

指導老師 Instructor(s)

顧媛媛

Yuan-Yuan Gu

學校所在地 Location of School

中國大陸

China

學校名稱 Name of School

南京師範大學

Nanjing Normal University



《九個人的快遞》書籍設計——原稿及書冊設計 / "Nine people express" book design - Draft explore section

## 機遇

### Opportunity

作者姓名 Name of Designer(s)

邢廷偉

Ting-Wei Xing

指導老師 Instructor(s)

劉瑤

Yao Liu

學校所在地 Location of School

中國大陸

China

學校名稱 Name of School

南京師範大學

Nanjing Normal University

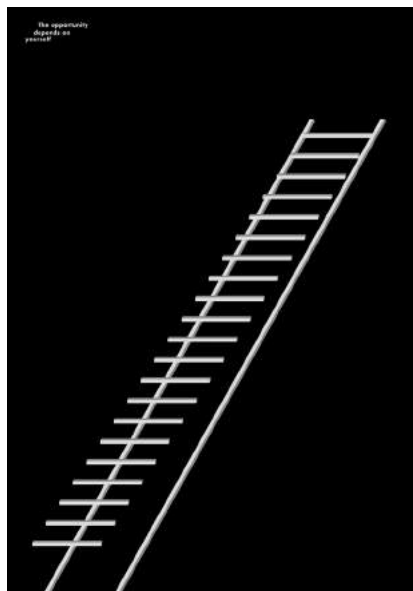

## 沒有霧霾

### No Haze

作者姓名 Name of Designer(s)

徐璇

Xuan Xu

指導老師 Instructor(s)

王勇

Yong Wang

學校所在地 Location of School

中國大陸

China

學校名稱 Name of School

南京師範大學

Nanjing Normal University





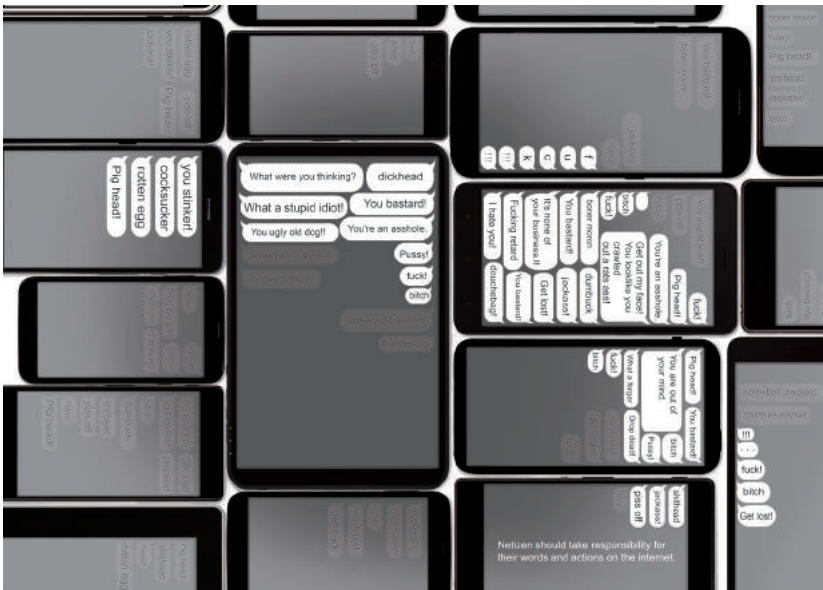

### 惡毒推文

#### Mean Twitter

作者姓名 Name of Designer(s)  
王昱超、黃士銘  
Yu-Chao Wang, Shi-Ming Huang

指導老師 Instructor(s)  
楊裕隆  
Yu-Lung Yang

學校所在地 Location of School  
臺灣  
Taiwan

學校名稱 Name of School  
樹德科技大學  
Shu-Te University



### 失去的童年

#### Lost Childhood

作者姓名 Name of Designer(s)  
王昱超、黃士銘  
Yu-Chao Wang, Shi-Ming Huang

指導老師 Instructor(s)  
楊裕隆  
Yu-Lung Yang

學校所在地 Location of School  
臺灣  
Taiwan

學校名稱 Name of School  
樹德科技大學  
Shu-Te University



### 甜蜜與苦澀

#### Sweet and Pained

作者姓名 Name of Designer(s)  
陳勵琪  
Li-Chi Chen

指導老師 Instructor(s)  
楊裕隆  
Yu-Lung Yang

學校所在地 Location of School  
臺灣  
Taiwan

學校名稱 Name of School  
樹德科技大學  
Shu-Te University

## Doors

作者姓名 Name of Designer(s)

Pearl Sevilla, Julian Panidar

指導老師 Instructor(s)

Dino Brucelas

學校所在地 Location of School

菲律賓

Republic of the Philippines

學校名稱 Name of School

聖貝寧德學院

School of Design and Arts - College of St.

Benidle

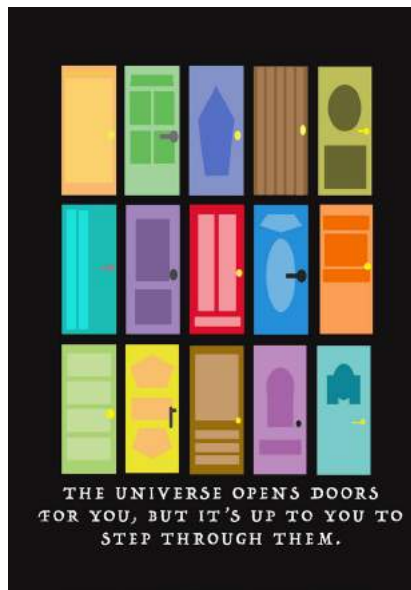

## 牠們很脆弱

### They Are so Fragile

作者姓名 Name of Designer(s)

張智皓

Chih-Hao Chang

指導老師 Instructor(s)

游明龍

Ming-Lung Yu

學校所在地 Location of School

臺灣

Taiwan

學校名稱 Name of School

國立雲林科技大學

National Yunlin University of Science and

Technology



## 面對機遇

### Facing Opportunities

作者姓名 Name of Designer(s)

王丹

Dan Wang

指導老師 Instructor(s)

吳瑩

Ying Wu

學校所在地 Location of School

中國大陸

China

學校名稱 Name of School

上海大學上海美術學院

Shanghai Academy of Fine Arts, Shanghai

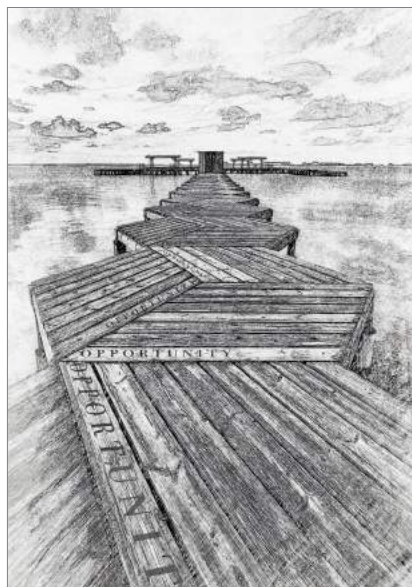



我為動物代言  
**I Speak for Animals**

作者姓名 Name of Designer(s)

肖文嬋

Wen-Chan Xiao

指導老師 Instructor(s)

焦長虹

Chang-Hong Jiao

學校所在地 Location of School

中國大陸

China

學校名稱 Name of School

陝西師範大學

Shaanxi Normal University

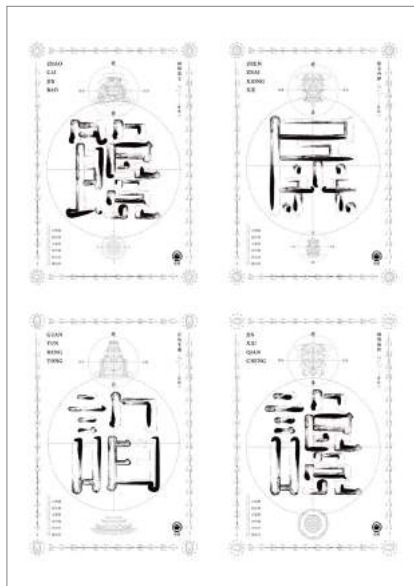
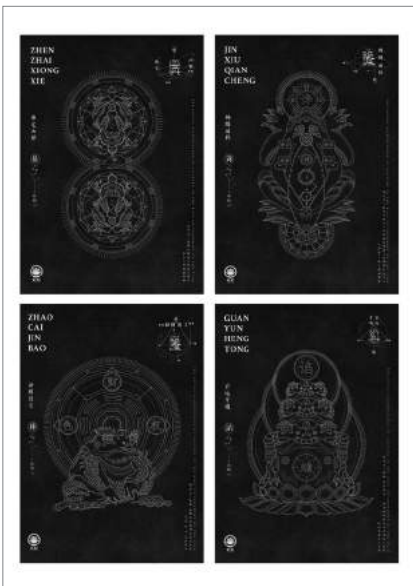

《蟾相》金蟾文化綜合  
視覺設計

**"Toad" Toad Culture**

**Comprehensive Visual Design**

作者姓名 Name of Designer(s)

李小康

Xiao-Kang Li

指導老師 Instructor(s)

員勃

Bo Yuan

學校所在地 Location of School

中國大陸

China

學校名稱 Name of School

武漢輕工大學

Wuhan Polytechnic University

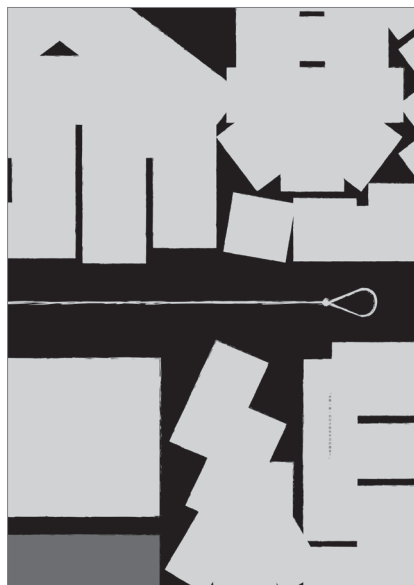

一線生機

**A Slim Chance of Survival**

作者姓名 Name of Designer(s)

吳淇宇

Chi-Yu Wu

指導老師 Instructor(s)

無

None

學校所在地 Location of School

臺灣

Taiwan

學校名稱 Name of School

華梵大學

Huafan University



圓形天空  
Cercle Sky

作者姓名 Name of Designer(s)  
阮宜婷  
li-Ting Juan  
指導老師 Instructor(s)  
陳盈秀  
Ying-Xiu Chen  
學校所在地 Location of School  
臺灣  
Taiwan  
學校名稱 Name of School  
明志科技大學  
Ming Chi University of Technology



肇興侗寨  
ZhaoXing

作者姓名 Name of Designer(s)  
楊榮燦  
Acan Yang  
指導老師 Instructor(s)  
萬蓉  
Rong Wan  
學校所在地 Location of School  
中國大陸  
China  
學校名稱 Name of School  
四川音樂學院  
Sichuan Conservatory of Music

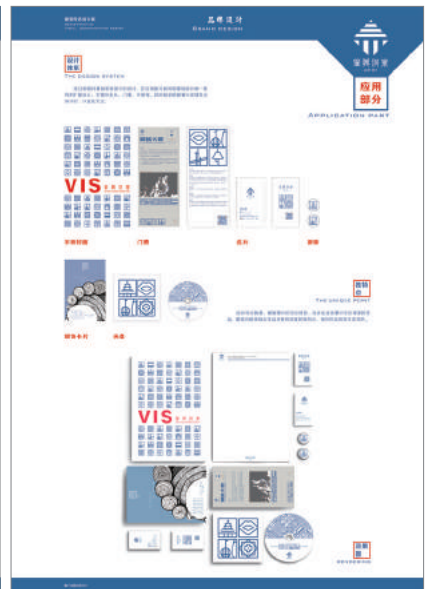

溯洄  
Go Upstream

作者姓名 Name of Designer(s)  
吳海燕  
Hai-Yan Wu  
指導老師 Instructor(s)  
萬蓉  
Rong Wan  
學校所在地 Location of School  
中國大陸  
China  
學校名稱 Name of School  
四川音樂學院成都美術學院  
Chengdu Academy of Fine Arts



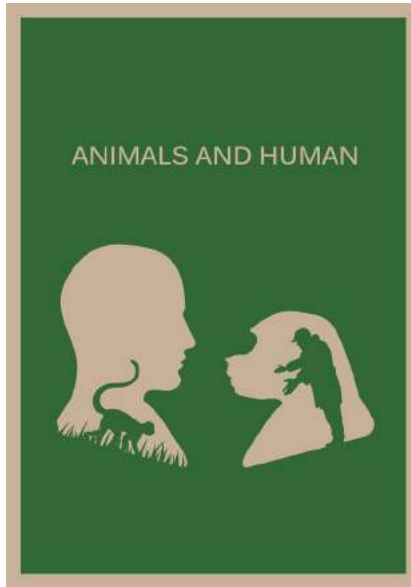

**動物與人類**  
**Animals and Human**

作者姓名 Name of Designer(s)  
葉芷萱、林勤婕、黃靖娟、潘彥伶  
Chih-Hsuan Yeh, Cin-Jie Lin,  
Ching-Chuan Huang, Yen-Ling Pan  
指導老師 Instructor(s)  
李文淵  
Wen-Yuan Lee  
學校所在地 Location of School  
臺灣  
Taiwan  
學校名稱 Name of School  
大同大學  
Tatung University



**意外死亡**  
**Accidental Death**

作者姓名 Name of Designer(s)  
楊歡  
Huan Yang  
指導老師 Instructor(s)  
念凡  
Fan Nian  
學校所在地 Location of School  
中國大陸  
China  
學校名稱 Name of School  
福州大學廈門工藝美術學院  
Xiamen Academy of Arts and Design,  
Fuzhou University

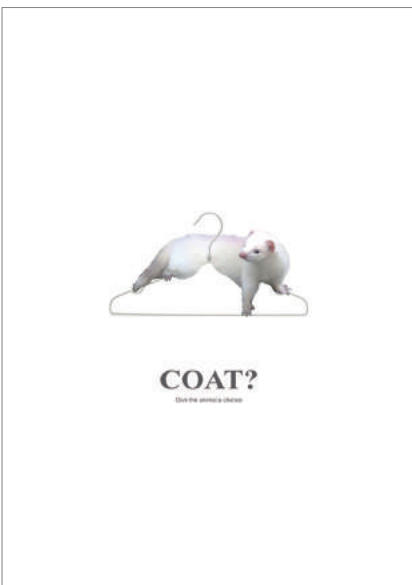

**給動物一個機會**  
**Give the Animal a Chance**

作者姓名 Name of Designer(s)  
鄒國明  
Kuo-Ming Tsou  
指導老師 Instructor(s)  
符逸群、楊鼎獻  
Yi-Qun Fu, Ding-Xian Yang  
學校所在地 Location of School  
臺灣  
Taiwan  
學校名稱 Name of School  
嶺東科技大學  
Ling Tung University

## 留守兒童

### Left-Behind

作者姓名 Name of Designer(s)

李沈挺

Shen-Ting Li

指導老師 Instructor(s)

Jana Dambekalne

學校所在地 Location of School

新加坡

Singapore

學校名稱 Name of School

萊佛士高等教育學院

Raffles College for Higher Education

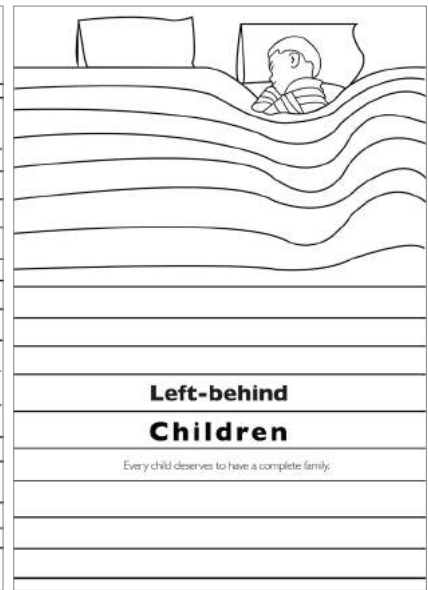
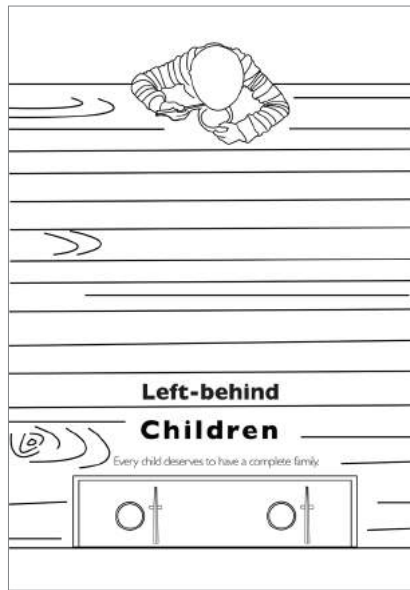

## 反對家庭暴力

### Against Domestic Violence

作者姓名 Name of Designer(s)

葉蘊儀

Yun-Yi Ye

指導老師 Instructor(s)

Jana Dambekalne

學校所在地 Location of School

新加坡

Singapore

學校名稱 Name of School

萊佛士高等教育學院

Raffles College for Higher Education



## Opportunity of Failure

作者姓名 Name of Designer(s)

Ardine Devina Rasak

指導老師 Instructor(s)

Jana Dambekalne

學校所在地 Location of School

新加坡

Singapore

學校名稱 Name of School

萊佛士設計學院

Raffles Design Institute







### Opportunity for Lgbt Poster

作者姓名 Name of Designer(s)

Yap Henn Yee Alyssa

指導老師 Instructor(s)

無

None

學校所在地 Location of School

新加坡

Singapore

學校名稱 Name of School

萊佛士設計學院

Raffles Design Institute



### 樹醫日誌

#### Tree Doctor's Journal

作者姓名 Name of Designer(s)

吳承容、賴又璋、陳聖元、謝亞築、  
傅欽雅

Cheng-Rong Wu, You-Wei Lai,

Sheng-Yuan Chen, Ya-Zhu Xie, Xin-Ya Fu

指導老師 Instructor(s)

無

None

學校所在地 Location of School

臺灣

Taiwan

學校名稱 Name of School

建國科技大學

Chienkuo Technology University



### 獨白

#### Monologue

作者姓名 Name of Designer(s)

王曙亮

Shu-Liang Wang

指導老師 Instructor(s)

無

None

學校所在地 Location of School

中國大陸

China

學校名稱 Name of School

廣西民族師範學院

Guangxi Normal University for

Nationalities

勇氣

**Courage**

作者姓名 Name of Designer(s)

李玟珊

Wen-Shan Lee

指導老師 Instructor(s)

林文彥

Wen-Yen Lin

學校所在地 Location of School

臺灣

Taiwan

學校名稱 Name of School

嘉南藥理大學

Chia Nan University of Pharmacy & Science

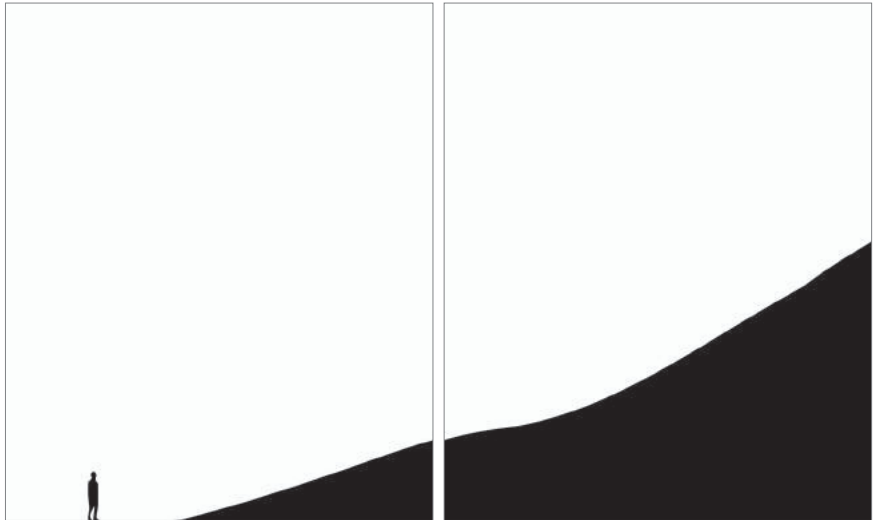

**Out of the Box**

作者姓名 Name of Designer(s)

Iwan-Kurnia, Guntur Dwi Wijaksono,  
Azis Teja Sukmana

指導老師 Instructor(s)

無

None

學校所在地 Location of School

印尼

Indonesia

學校名稱 Name of School

印度尼西亞教育大學

Indonesia University of Education

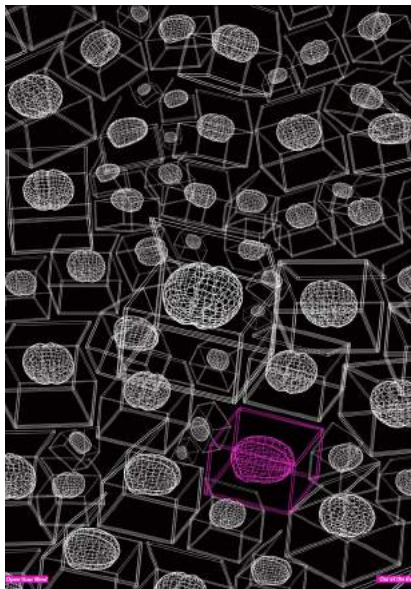

救衣，不舊衣

**Save Clothes and Don't  
Discard Old Clothes**

作者姓名 Name of Designer(s)

江宇軒、劉蘊滕、譚心宇、張閑鈞

Yu-Shiuan Jiang, Yun-Teng Liu,  
Hsing-Yu Tan, Sian-Fang Jhang

指導老師 Instructor(s)

林永雲

Yong-Yun Lin

學校所在地 Location of School

臺灣

Taiwan

學校名稱 Name of School

醒吾科技大學

Hsing Wu University of Science and  
Technology







**Poster**

作者姓名 Name of Designer(s)

Dariush Allahyari

指導老師 Instructor(s)

Iraj Mirza Alikhani

學校所在地 Location of School

伊朗

Iran

學校名稱 Name of School

納比阿克蘭大學

University College of Nabi Akram



**《神農本草經》品牌形象設計**

**Brand Image Design of Shen Nong's Materia Medica**

作者姓名 Name of Designer(s)

周斯琪、何青青、李春燕、楊玲、胡鈺琦、劉芳

Si-Qi Zhou, Qing-Qing He, Chun-Yan Li, Ling Yang, Yu-Qi Hu, Fang Liu

指導老師 Instructor(s)

許倩

Qian Xu

學校所在地 Location of School

中國大陸

China

學校名稱 Name of School

成都藝術職業學院

Chengdu Arts Vocational College



**地瓜概念**

**Thrive**

作者姓名 Name of Designer(s)

郭昕岳、鄒鈞達、簡廷禎、王郁昀、王築、曹芳瑀、劉庭瑄、劉維葵

Hsing-Yueh Guo, Yun-Da Tzou, Ting-Jhen Jian, Yu-Yun Wang, Chu Wang, Fang-Yu Cao, Ting-Hsuan Liu, Wei-Zhen Liu

指導老師 Instructor(s)

鄭明輝

Ming-Hui Cheng

學校所在地 Location of School

臺灣

Taiwan

學校名稱 Name of School

崑山科技大學

Kun Shan University



嘎嘎好農

GaGa Farming

作者姓名 Name of Designer(s)  
謝馥羽、廖心慈、巫孜勤、黃鼎驊  
Fu-Yu Sie, Hsin-Tzu Liao, Tz-Chin Wu,  
Ding-Hua Huang

指導老師 Instructor(s)  
詹玉艷  
Yu-Yen Chan

學校所在地 Location of School  
臺灣  
Taiwan

學校名稱 Name of School  
國立臺中科技大學  
National Taichung University of Science and  
Technology



The Opportunity to Be Free

作者姓名 Name of Designer(s)  
Abby Liew May Xing

指導老師 Instructor(s)  
Patrick Min

學校所在地 Location of School  
馬來西亞  
Malaysia

學校名稱 Name of School  
吉隆坡萊佛士高等學院  
Raffles College of Higher Education Kuala  
Lumpur



"故障入侵" 突發性故障圖像  
視覺語言研究

"The Invasion of Glitch"-The Study  
of Visual Language of Paroxysmal  
Image Glitch

作者姓名 Name of Designer(s)  
竇源傑  
Yuan-Jie Dou

指導老師 Instructor(s)  
鐘舒  
Shu Zhong

學校所在地 Location of School  
中國大陸  
China

學校名稱 Name of School  
四川大學錦江學院  
Sichuan University Jinjiang College

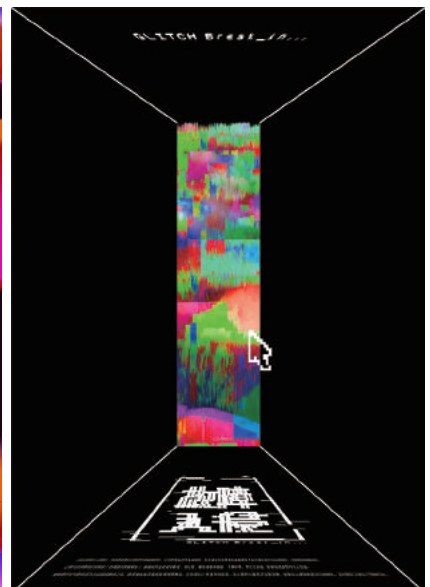



機遇，捕食篇

Predation

作者姓名 Name of Designer(s)

邱豔

Yan Qiu

指導老師 Instructor(s)

李冰潔

Bing-Jie Li

學校所在地 Location of School

中國大陸

China

學校名稱 Name of School

南京師範大學

Nanjing Normal University



生跡

Signs of Life

作者姓名 Name of Designer(s)

顏茂丞

Mao-Cheng Yan

指導老師 Instructor(s)

方曉偉

Hsiao-Wei Fang

學校所在地 Location of School

臺灣

Taiwan

學校名稱 Name of School

東方設計大學

Tung Fang Design University

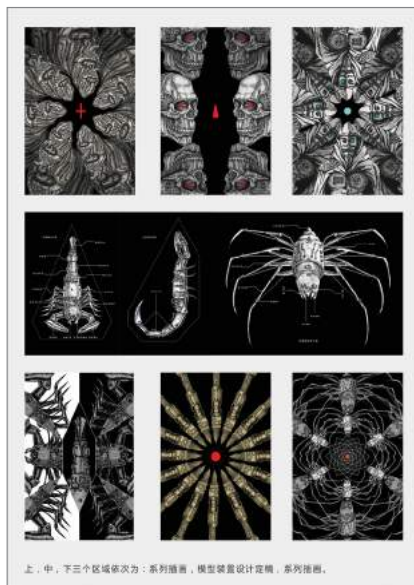

"毒金" 蒸汽朋克机械艺术视觉语言研究

"Poison Gold"- Research on the Visual Language of Steam Punk's Mechanical Art

作者姓名 Name of Designer(s)

任靖翊

Jing-Yi Ren

指導老師 Instructor(s)

王少文

Shao-Wen Wang

學校所在地 Location of School

中國大陸

China

學校名稱 Name of School

四川大學錦江學院

Sichuan University Jinjiang College

!  
!

作者姓名 Name of Designer(s)

李錦雯

Jin-Wun Lee

指導老師 Instructor(s)

翁漢騰、賀俊智

Han-Teng Weng, Jiun-Jhy Her

學校所在地 Location of School

臺灣

Taiwan

學校名稱 Name of School

國立臺東大學

National Taitung University



## Create

作者姓名 Name of Designer(s)

Quintn

指導老師 Instructor(s)

Anne Ahmad

學校所在地 Location of School

加拿大

Canada

學校名稱 Name of School

溫哥華藝術學院

The Art Institute of Vancouver

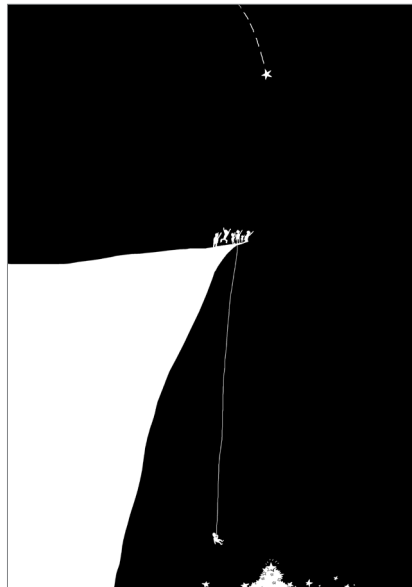

## 拾級

### Stair Up for Change

作者姓名 Name of Designer(s)

尤綵璘

Cai-Lin Yu

指導老師 Instructor(s)

李新富

Shin-Fu Lee

學校所在地 Location of School

臺灣

Taiwan

學校名稱 Name of School

亞洲大學

Asia University

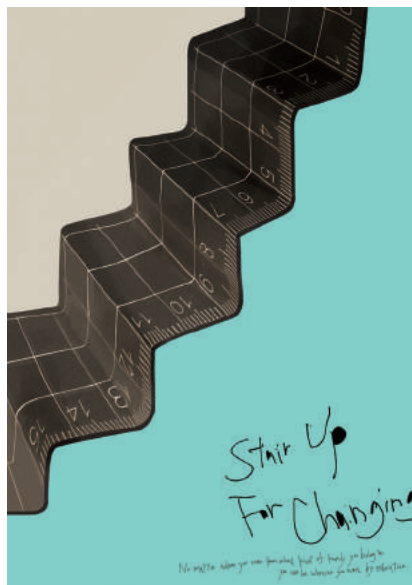



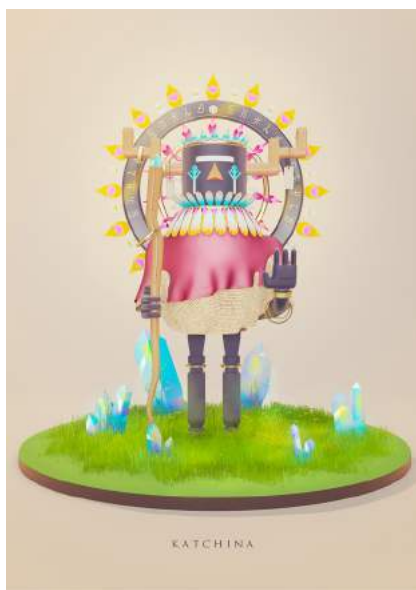

### Solar Eclipse Kachina

作者姓名 Name of Designer(s)  
Virgilio Abraham Cortez Recinos

指導老師 Instructor(s)  
無  
None

學校所在地 Location of School  
薩爾瓦多  
El Salvador

學校名稱 Name of School  
薩爾瓦多理工大學  
Universidad Tecnologica

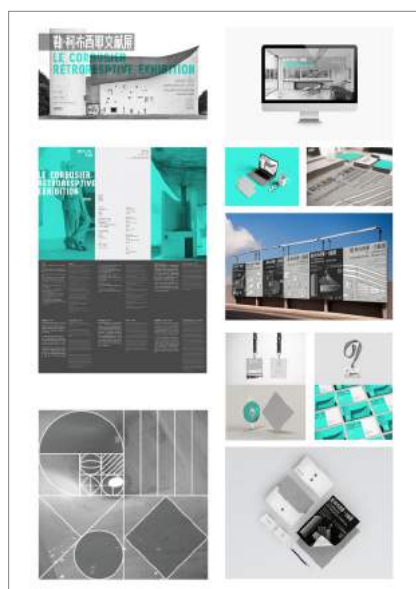
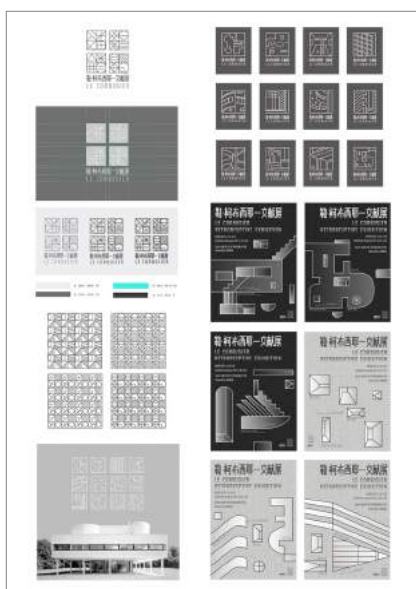

### 柯布西耶文獻展視覺設計 Visual Design of Corbusier Documents

作者姓名 Name of Designer(s)  
朱天航、周丹丹、梁子秋、張孟迪  
Tian-Hang Zhu, Dan-Dan Zhou,  
Zi-Qiu Liang, Meng-Di Zhang

指導老師 Instructor(s)  
厲勉、陳皓  
Mian Li, Hao Chen

學校所在地 Location of School  
中國大陸  
China

學校名稱 Name of School  
南京藝術學院  
Nanjing University of the Arts



### Art for Cause

作者姓名 Name of Designer(s)  
Rajdeep Chatterjee

指導老師 Instructor(s)  
無  
None

學校所在地 Location of School  
印度  
India

學校名稱 Name of School  
國家創意傳播研究所  
National Institute of Creative  
Communication



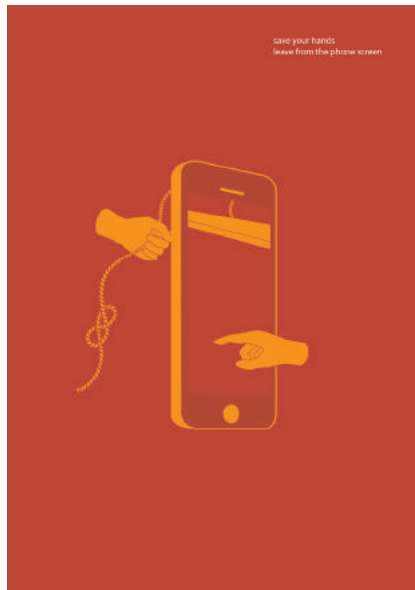

## 手“機”

### Phone Torture

作者姓名 Name of Designer(s)

吳雙

Shuang Wu

指導老師 Instructor(s)

李新富

Shin-Fu Lee

學校所在地 Location of School

臺灣

Taiwan

學校名稱 Name of School

亞洲大學

Asia University

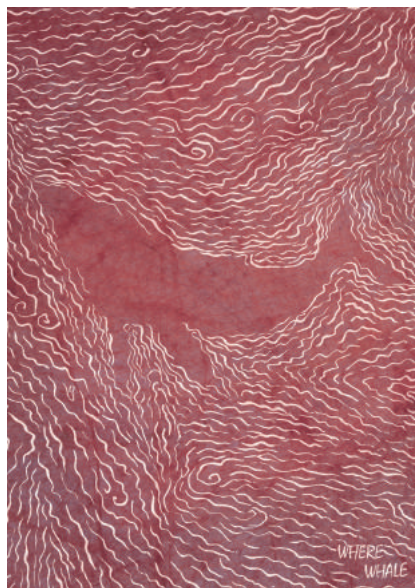

## Where Whale

作者姓名 Name of Designer(s)

葉江風

Jiang-Feng Ye

指導老師 Instructor(s)

林俊良、劉建成、戚躍春、游明龍

Chun-Liang Lin, Chien-Cheng Liu,

Yue-Chun Qi, Ming-Lung Yu

學校所在地 Location of School

臺灣

Taiwan

學校名稱 Name of School

國立臺灣師範大學

National Taiwan Normal University



## 人人都想拯救世界，卻沒有人幫媽媽洗碗

### Everyone Wants to Save the World, but No One Helps His Mother Wash the Dishes

作者姓名 Name of Designer(s)

蔡信弘

Xin-Hung Cai

指導老師 Instructor(s)

張文化

Wen-Hua Zhang

學校所在地 Location of School

中國大陸

China

學校名稱 Name of School

廈門大學

Xiamen University



請讓我活下去

**Please Let Me Live**

作者姓名 Name of Designer(s)

林芷萱

Zhi-Xuan Lin

指導老師 Instructor(s)

黃郁升

Yu-Sheng Huang

學校所在地 Location of School

臺灣

Taiwan

學校名稱 Name of School

正修科技大學

Cheng Shiu University



天賦

**Natural Gift**

作者姓名 Name of Designer(s)

黃意君

Yi-Chun Huang

指導老師 Instructor(s)

趙飛帆

Fei-Fan Chao

學校所在地 Location of School

臺灣

Taiwan

學校名稱 Name of School

國立雲林科技大學

National Yunlin University of Science and

Technology

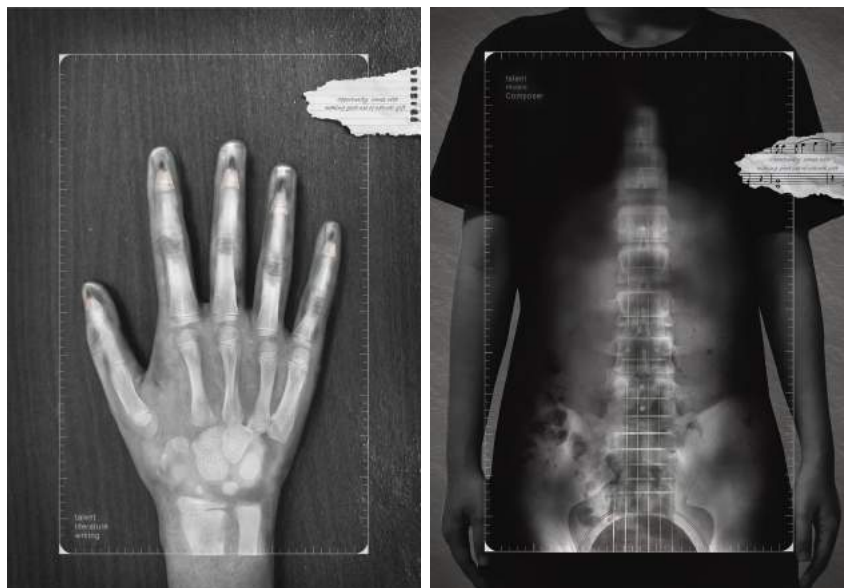

**Seize the Opportunity**

作者姓名 Name of Designer(s)

Ha-Eun Oh

指導老師 Instructor(s)

Geun-Yeol Son

學校所在地 Location of School

韓國

Korea

學校名稱 Name of School

仁德大學

Induk University

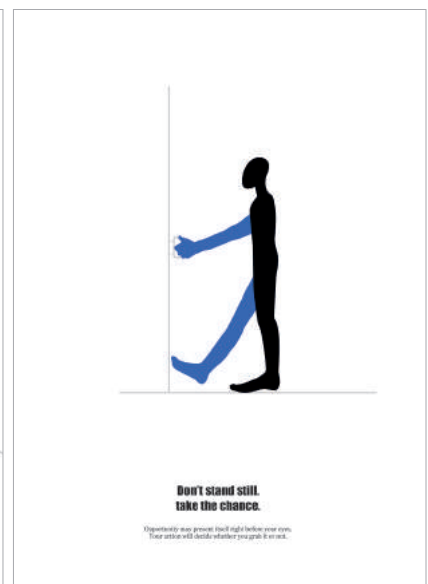





《字繪中國》系列  
《Font Design for China》  
Series

作者姓名 Name of Designer(s)

劉琺穎  
Jun-Ying Liu

指導老師 Instructor(s)

徐鄭冰、沈娟  
Zheng-Bing Xu, Juan Shen

學校所在地 Location of School

中國大陸  
China

學校名稱 Name of School

武漢工商學院  
Wuhan Business University

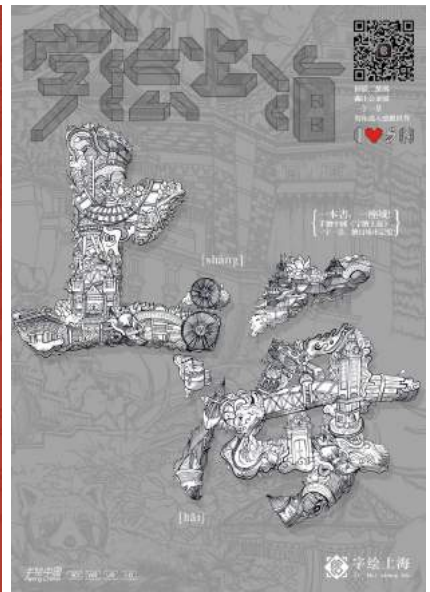
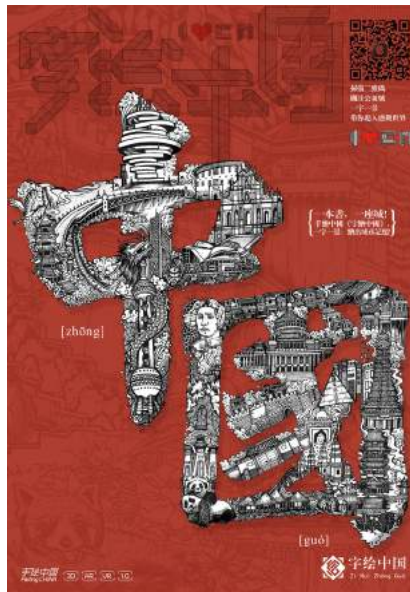

Values

作者姓名 Name of Designer(s)

Sheng Pang Kueh

指導老師 Instructor(s)

無  
None

學校所在地 Location of School

馬來西亞  
Malaysia

學校名稱 Name of School

達爾尚藝術學院  
Dasein Academy of Art



Animal Right

作者姓名 Name of Designer(s)

李佩娟  
Pei-Chuan Li

指導老師 Instructor(s)

林俊良  
Chun-Laing Lin

學校所在地 Location of School

臺灣  
Taiwan

學校名稱 Name of School

國立臺灣師範大學  
National Taiwan Normal University

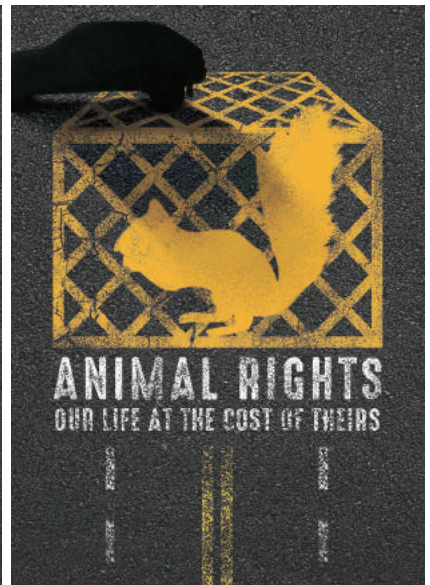
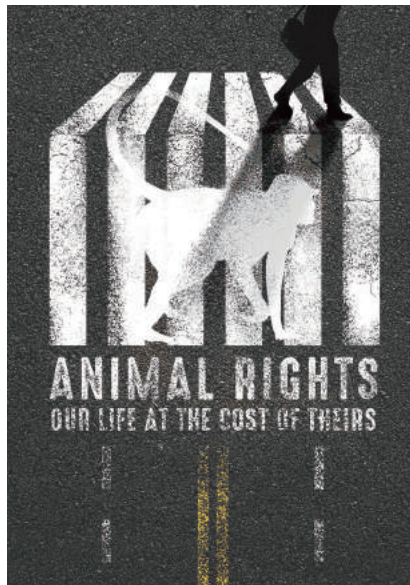



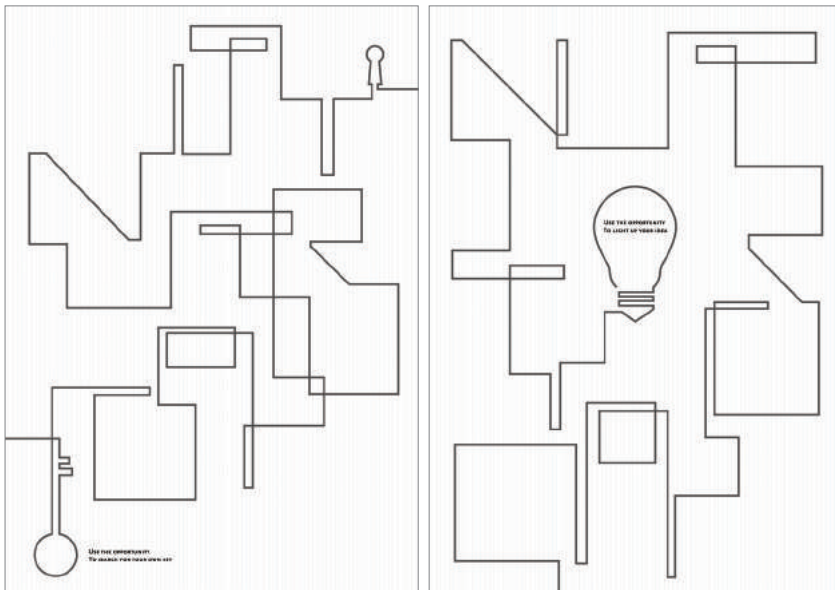

### Find Yourself

作者姓名 Name of Designer(s)

曾品耘

Pin-Yun Tseng

指導老師 Instructor(s)

Hirokazu Sato

學校所在地 Location of School

日本

Japan

學校名稱 Name of School

京都造形藝術大學

Kyoto University of Art and Design

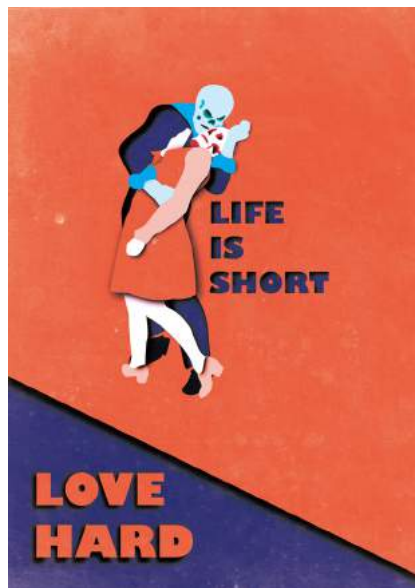

### 愛要及時

#### Love Hard

作者姓名 Name of Designer(s)

張嘉鈞

Chia-Chung Chang

指導老師 Instructor(s)

劉建成

Chien-Cheng Liu

學校所在地 Location of School

臺灣

Taiwan

學校名稱 Name of School

國立臺灣師範大學

National Taiwan Normal University



### Ladder

作者姓名 Name of Designer(s)

Jayashree Venkat

指導老師 Instructor(s)

S Balaram

學校所在地 Location of School

印度

India

學校名稱 Name of School

DJ 設計學院

DJ Academy of Design

機遇與鸵鳥

Opportunity and Ostrich

作者姓名 Name of Designer(s)

王璐瑶  
Lu-Yao Wang

指導老師 Instructor(s)

端木丹青  
Dan-Qing Duanmu

學校所在地 Location of School

中國大陸  
China

學校名稱 Name of School

南京大學金陵學院  
Nanjing University Jinling College

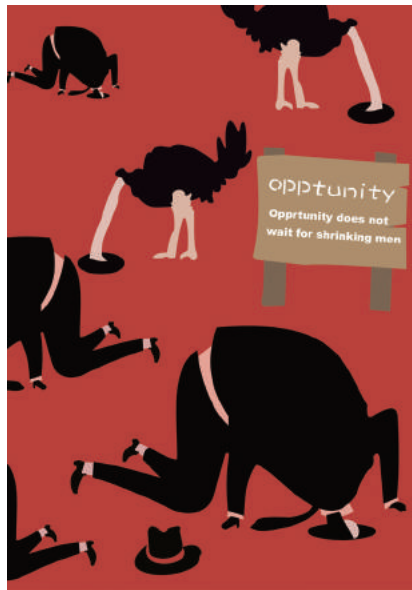

櫻桃未熟

Unripe Cherry

作者姓名 Name of Designer(s)

鮑雅雯  
Ya-Wen Bao

指導老師 Instructor(s)

肖勇、陳慰平、何浩、蔣華  
Yong Xiao, Marco Chan, Hao He, Hua Jiang

學校所在地 Location of School

挪威  
Norway

學校名稱 Name of School

卑爾根大學  
University of Bergen



漢字體驗館

A Journey of Chinese Characters

作者姓名 Name of Designer(s)

李嗣洋  
Si-Yang Li

指導老師 Instructor(s)

無  
None

學校所在地 Location of School

美國  
United States of America

學校名稱 Name of School

芝加哥藝術學院  
School of the Art Institute of Chicago





### 生命的審判

#### Trial of Life

作者姓名 Name of Designer(s)

李曉琳

Xiao-Lin Li

指導老師 Instructor(s)

宋毅仁

I-Zen Sung

學校所在地 Location of School

無

None

學校名稱 Name of School

江西農業大學

Jiangxi Agricultural University

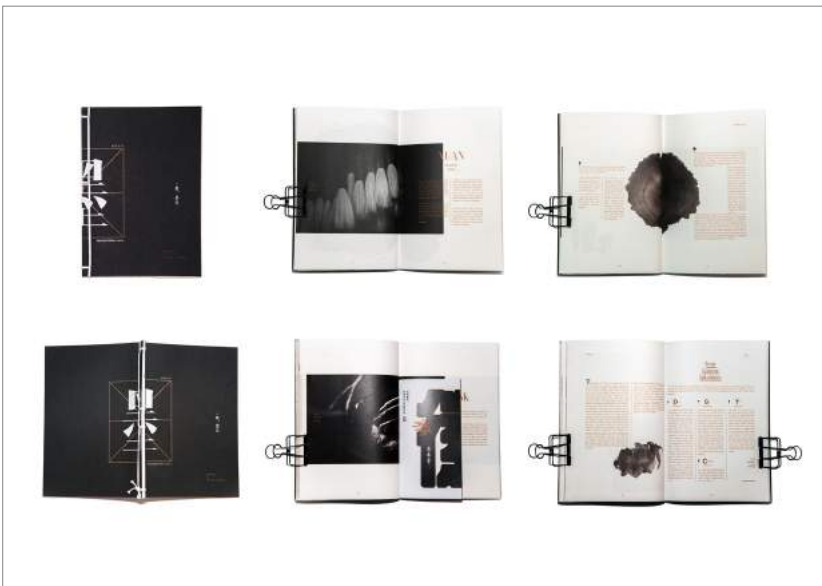

### 墨

#### Mo

作者姓名 Name of Designer(s)

沙鋒

Feng Sha

指導老師 Instructor(s)

Paolo Parisi

學校所在地 Location of School

義大利

Italy

學校名稱 Name of School

佛羅倫斯美術學院

Florence Academy of Art



### 意境

#### Ingenuity Follows Nature

作者姓名 Name of Designer(s)

沙鋒

Feng Sha

指導老師 Instructor(s)

Paolo Parisi

學校所在地 Location of School

義大利

Italy

學校名稱 Name of School

佛羅倫斯美術學院

Florence Academy of Art



詩文字造

Poem Text Made

作者姓名 Name of Designer(s)

趙娜

Na Zhao

指導老師 Instructor(s)

孫亞軍

Ya-Jun Sun

學校所在地 Location of School

中國大陸

China

學校名稱 Name of School

江蘇師範大學

Jiangsu Normal University

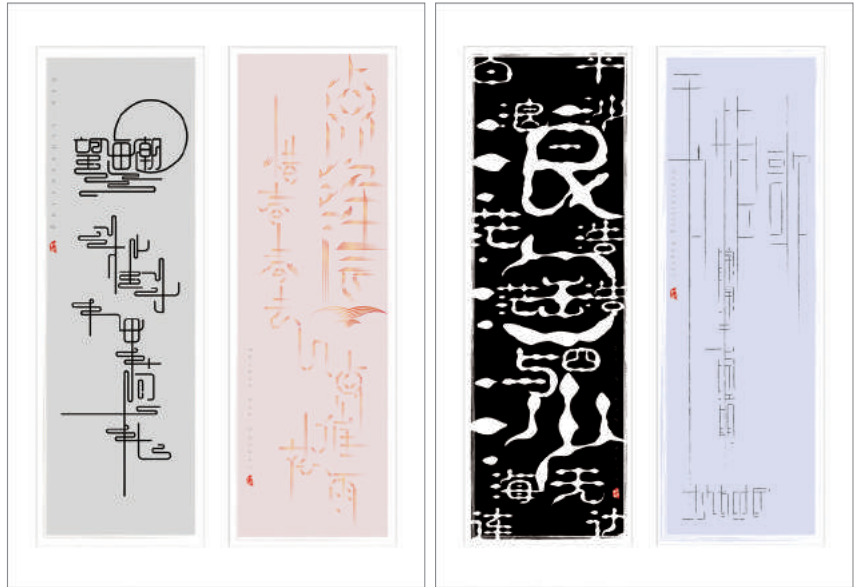

來去匆匆

They Never Wait

作者姓名 Name of Designer(s)

李盛湧

Seng-Yong Lee

指導老師 Instructor(s)

傑林

Jay Lim

學校所在地 Location of School

馬來西亞

Malaysia

學校名稱 Name of School

Point 學院

Point College Malaysia



生態郵繫

Post Care

作者姓名 Name of Designer(s)

曾敏嘉、林盈秀、黃品瑄、賴奕奴、

楊宜昕

Min-Chia Tseng, Ying-Xiu Lin,

Pin-Xuan Huang, Yi-Wen Lai, Yi-Xin Yang

指導老師 Instructor(s)

陳政昌

Cheng-Chang Chen

學校所在地 Location of School

臺灣

Taiwan

學校名稱 Name of School

樹德科技大學

Shu-Te University





機會

Opportunity

作者姓名 Name of Designer(s)

董志業

Zhi-Ye Dong

指導老師 Instructor(s)

王藝湘、郝林彤

Yi-Xiang Wang, Lin-Tong Jia

學校所在地 Location of School

中國大陸

China

學校名稱 Name of School

天津科技大學

Tianjin University of Science & Technology



樂觀主義者

Optimist

作者姓名 Name of Designer(s)

艾燕婷

Yan-Ting Ai

指導老師 Instructor(s)

無

None

學校所在地 Location of School

中國大陸

China

學校名稱 Name of School

湖北經濟學院

Hubei University of Economics

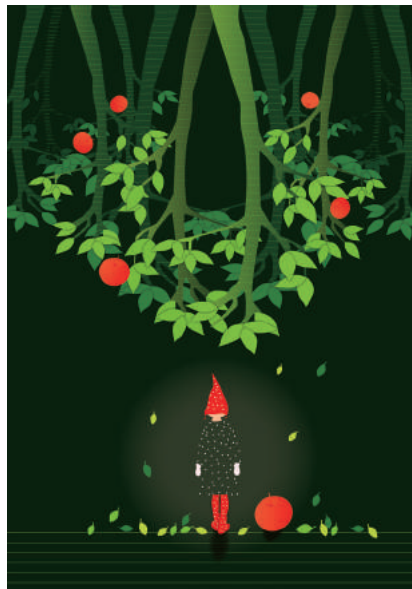

"少吃糖"

Don't Eat too Much Candies

作者姓名 Name of Designer(s)

丁榮輝

Ron-Ghui Ding

指導老師 Instructor(s)

李新富

Shin-Fu Lee

學校所在地 Location of School

中國大陸

China

學校名稱 Name of School

福州大學廈門工藝美術學院

Xiamen Academy of Arts and Design, Fuzhou University







**自定義公園**  
**Custom Park**

作者姓名 Name of Designer(s)

陳潔  
Yuuyo Chen

指導老師 Instructor(s)

王帆  
Fan Wang

學校所在地 Location of School

中國大陸  
China

學校名稱 Name of School

南京藝術學院  
Nanjing University of the Arts



**康定斯基藝術展**  
**Kandinsky Art Exhibition**

作者姓名 Name of Designer(s)

陳潔、林志強、劉黎勇、馬彥君  
Yuuyo Chen, Zhi-Qiang Lin, Li-Yong Liu,  
Yan-Jun Ma

指導老師 Instructor(s)

陳皓  
Hao Chen

學校所在地 Location of School

中國大陸  
China

學校名稱 Name of School

南京藝術學院  
Nanjing University of the Arts

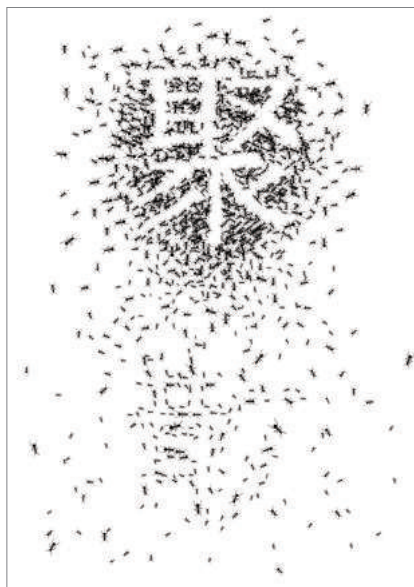

**聚散**  
**Meeting and Parting**

作者姓名 Name of Designer(s)

劉波禕  
Bo-Yi Liu

指導老師 Instructor(s)

李孟宣  
Meng-Xuan Li

學校所在地 Location of School

中國大陸  
China

學校名稱 Name of School

吉林藝術學院  
Jilin University of the Arts

## Multiply

作者姓名 Name of Designer(s)

Andrea Kováčová

指導老師 Instructor(s)

Andrej Haščák

學校所在地 Location of School

斯洛伐克

Slovakia

學校名稱 Name of School

科希策技術大學

Technical University of Košice

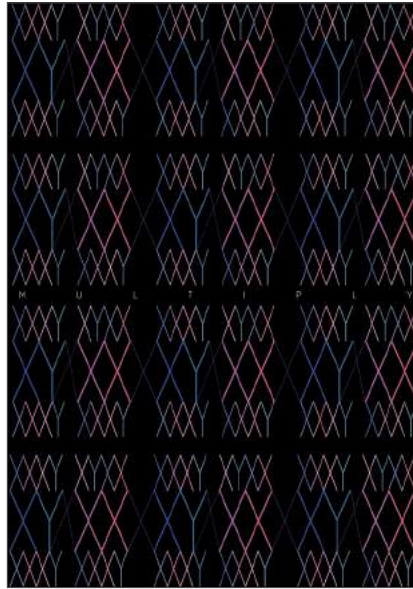

## Museum of Time Identity

作者姓名 Name of Designer(s)

Jens Marklund

指導老師 Instructor(s)

Eric Baker

學校所在地 Location of School

美國

United States of America

學校名稱 Name of School

紐約視覺藝術學院

School of Visual Arts



## 超越生命

### Beyond Life

作者姓名 Name of Designer(s)

陳君如

Jyun-Ru Chen

指導老師 Instructor(s)

洪世杰

Shih-Chieh Hung

學校所在地 Location of School

臺灣

Taiwan

學校名稱 Name of School

東方設計大學

Tung Fang Design University

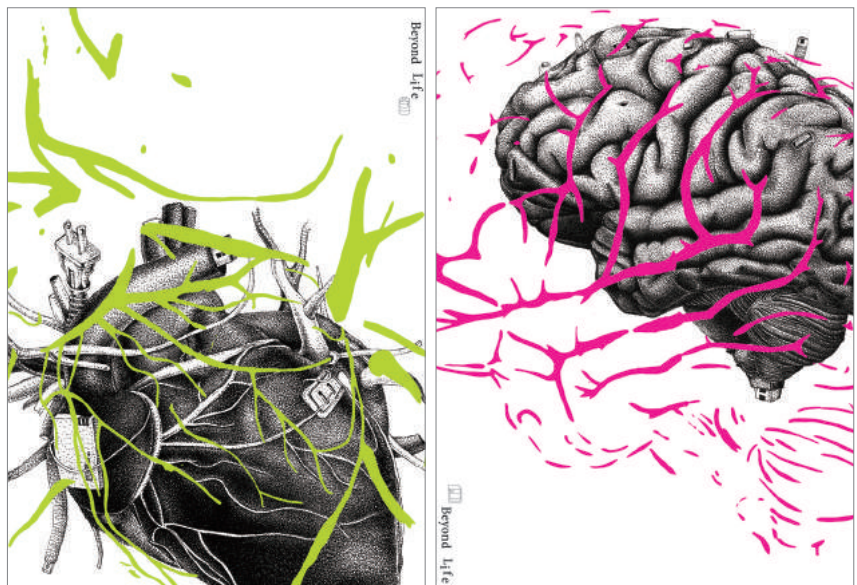

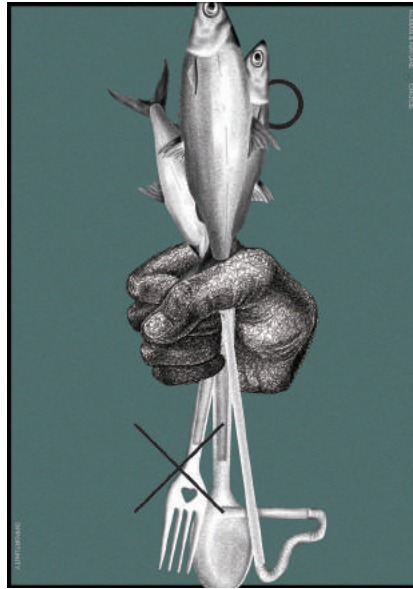
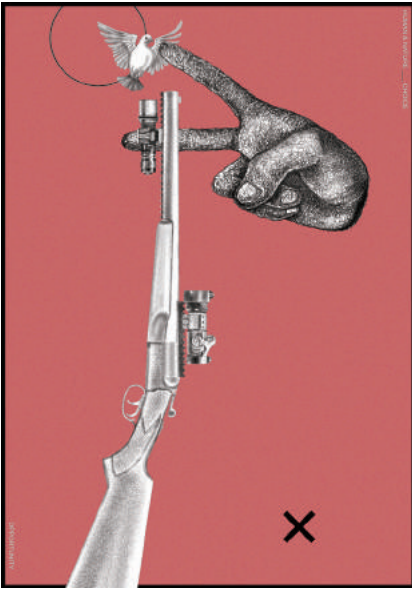

機會

**Nature & Human\_Choice**

作者姓名 Name of Designer(s)

陳君如

Jyun-Ru Chen

指導老師 Instructor(s)

洪世杰

Shih-Chieh Hung

學校所在地 Location of School

臺灣

Taiwan

學校名稱 Name of School

東方設計大學

Tung Fang Design University

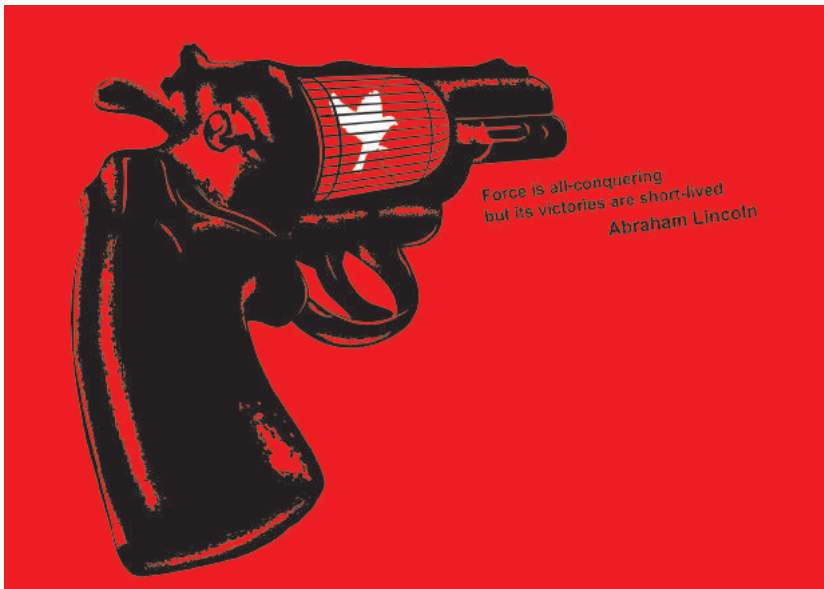

反戰

**Pacification**

作者姓名 Name of Designer(s)

黃士銘、王昱超

Shi-Ming Huang, Yu-Chao Wang

指導老師 Instructor(s)

楊裕隆

Yu-Lung Yang

學校所在地 Location of School

臺灣

Taiwan

學校名稱 Name of School

樹德科技大學

Shu-Te University

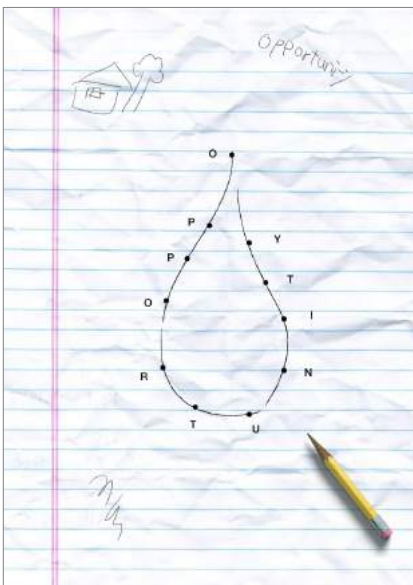

**Moment of Opportunity**

作者姓名 Name of Designer(s)

Yi-Seul Choi

指導老師 Instructor(s)

Bang-Won Lee

學校所在地 Location of School

韓國

Korea

學校名稱 Name of School

仁德大學

Induk University



## Illumination

作者姓名 Name of Designer(s)

Tasnim Tinawi

指導老師 Instructor(s)

無

None

學校所在地 Location of School

阿拉伯聯合大公國

United Arab Emirates

學校名稱 Name of School

美國沙迦大學

American University of Sharjah

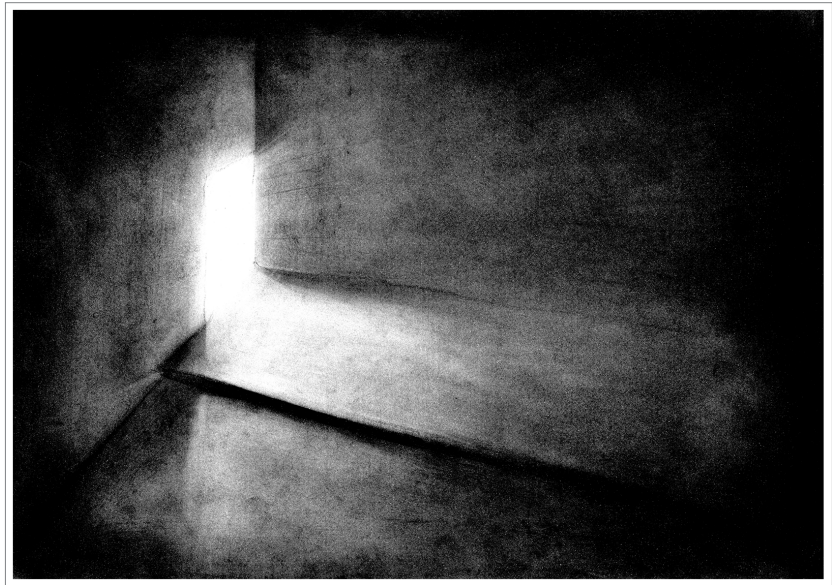

## 機遇

### Opportunities

作者姓名 Name of Designer(s)

岳雲霄、王慧芳

Yun-Xiao Yue, Hui-Fang Wang

指導老師 Instructor(s)

戚躍春、張文化

Yue-Chun Qi, Wen-Hua Zhang

學校所在地 Location of School

中國大陸

China

學校名稱 Name of School

廈門大學

Xiamen University

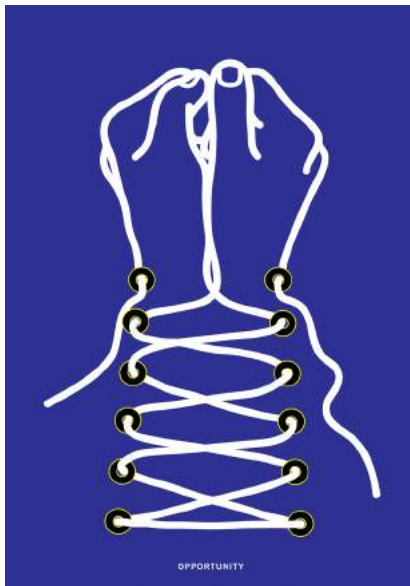

## 我不知道

### I Don't Know

作者姓名 Name of Designer(s)

馬浩軒

Hao-Xuan Ma

指導老師 Instructor(s)

湯娜

Na Tang

學校所在地 Location of School

中國大陸

China

學校名稱 Name of School

天津商業大學

Tianjin University of Commerce





印跡

Print

作者姓名 Name of Designer(s)

馬浩軒  
Hao-Xuan Ma

指導老師 Instructor(s)

湯娜  
Na Tang

學校所在地 Location of School

中國大陸  
China

學校名稱 Name of School

天津商業大學  
Tianjin University of Commerce

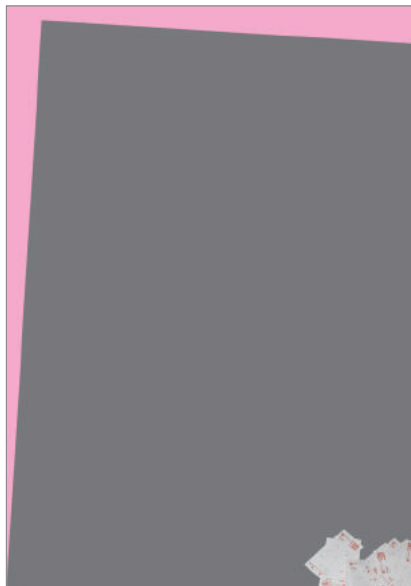

雜糅出版：備忘錄之詩

Temporary Poetry

作者姓名 Name of Designer(s)

孫宇飛  
Yu-Fei Sun

指導老師 Instructor(s)

無  
None

學校所在地 Location of School

中國大陸  
China

學校名稱 Name of School

中國美術學院  
China Academy of Art



Let's Make the Office

Great Again!

作者姓名 Name of Designer(s)

Johannes Winkler, Felix Vorbeck

指導老師 Instructor(s)

Bernhard Franken, Laurent Lacour

學校所在地 Location of School

德國  
Germany

學校名稱 Name of School

杜塞爾多夫應用技術大學  
University of Applied Sciences Düsseldorf

## 抓住機遇

### Seize the Opportunity

作者姓名 Name of Designer(s)

高蓉

Rong Gao

指導老師 Instructor(s)

李雙

Shang Li

學校所在地 Location of School

中國大陸

China

學校名稱 Name of School

福州大學

Fuzhou University



## Miss

作者姓名 Name of Designer(s)

Tran Thuy Trang

指導老師 Instructor(s)

Nguyen Hong Truong

學校所在地 Location of School

越南

Vietnam

學校名稱 Name of School

FPT 大學

FPT University



## Kukart Festival

作者姓名 Name of Designer(s)

Anatoly

指導老師 Instructor(s)

Nikolai Shtok

學校所在地 Location of School

俄羅斯

Russia

學校名稱 Name of School

莫斯科國家設計研究院

National Institute of Design in Moscow

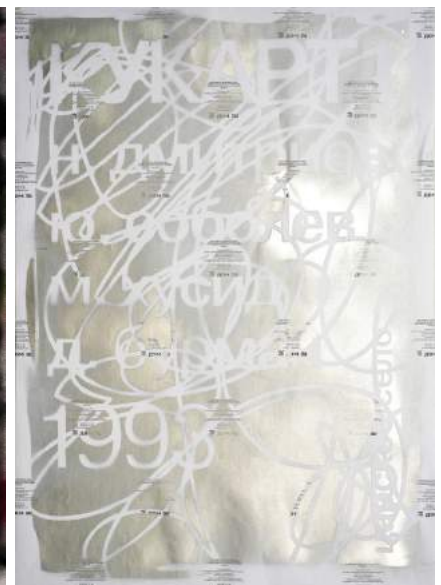





### Long Arms Festival

作者姓名 Name of Designer(s)  
Anatoly

指導老師 Instructor(s)  
Nikolai Shtok

學校所在地 Location of School  
俄羅斯  
Russia

學校名稱 Name of School  
莫斯科國家設計研究院  
National Institute of Design in Moscow

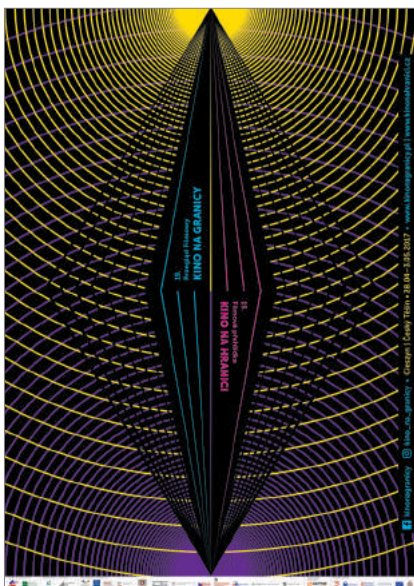

### 19th Cinema on the Border Film Festival | Event Identity

作者姓名 Name of Designer(s)  
Iwona Cichy

指導老師 Instructor(s)  
無  
None

學校所在地 Location of School  
波蘭  
Poland

學校名稱 Name of School  
卡托維茲西里西亞大學  
University of Silesia in Katowice



### 實驗咖啡 Experimental Coffee

作者姓名 Name of Designer(s)  
孫萌  
Meng Sun

指導老師 Instructor(s)  
曹方  
Fang Cao

學校所在地 Location of School  
中國大陸  
China

學校名稱 Name of School  
南京藝術學院  
Nanjing University of the Arts



匠心·傳承·築夢

**Ingenuity.Inherit.Building  
Dream**

作者姓名 Name of Designer(s)

嵇倩雲

Qian-Yun Ji

指導老師 Instructor(s)

曹方

Fang Cao

學校所在地 Location of School

中國大陸

China

學校名稱 Name of School

南京工業大學浦江學院

Nanjing Tech University Pujiang Institute

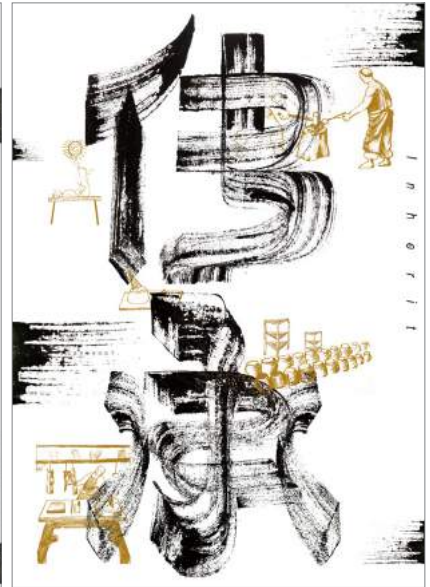
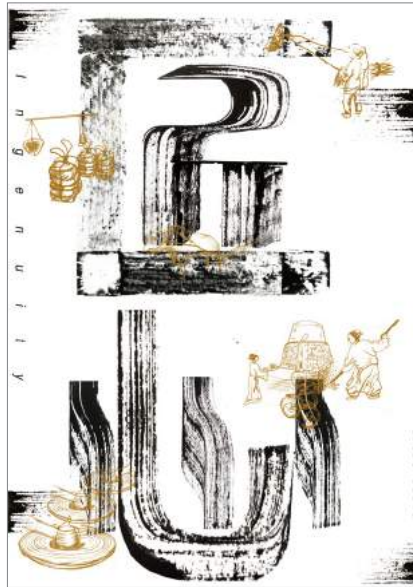

心聲

**Heart Sound**

作者姓名 Name of Designer(s)

李冠瑩

Guan-Ying Li

指導老師 Instructor(s)

郭正雄、黃國樑

Jheng-Syong Guo, Guo-Liang Huang

學校所在地 Location of School

臺灣

Taiwan

學校名稱 Name of School

南華大學

Nanhua University



一 "善" 門

**The Gate of Opportunity**

作者姓名 Name of Designer(s)

張雁

Yan Zhang

指導老師 Instructor(s)

馬青

Qing Ma

學校所在地 Location of School

中國大陸

China

學校名稱 Name of School

常州大學

Changzhou University



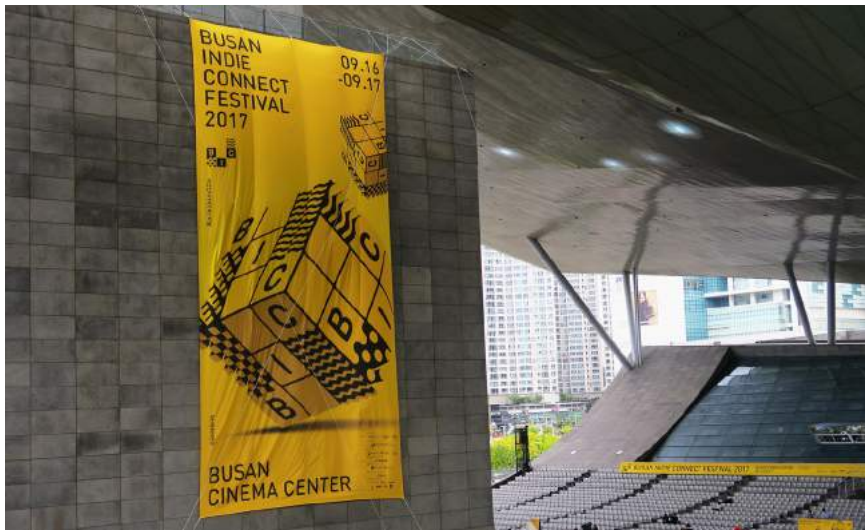

### Busan Indie Connect Festival 2017

作者姓名 Name of Designer(s)

Jaeho Shin

指導老師 Instructor(s)

無

None

學校所在地 Location of School

韓國

Korea

學校名稱 Name of School

韓世大學

Hansei University



### 盛宴

### Feast

作者姓名 Name of Designer(s)

王晨旭

Chen-Xu Wang

指導老師 Instructor(s)

黃光輝、吳臻

Guang-Hui Huang, Zhen Wu

學校所在地 Location of School

澳門

Macau

學校名稱 Name of School

澳門科技大學

Macau University of Science and Technology



### See

作者姓名 Name of Designer(s)

Darusalam

指導老師 Instructor(s)

無

None

學校所在地 Location of School

印尼

Indonesia

學校名稱 Name of School

Mercu Buana 大學

Mercu Buana University



機會呀

Opportunity

作者姓名 Name of Designer(s)

鄒晨

Chen Zou

指導老師 Instructor(s)

無

None

學校所在地 Location of School

中國大陸

China

學校名稱 Name of School

福州大學廈門工藝美術學院

Xiamen Academy of Arts and Design, Fuzhou University

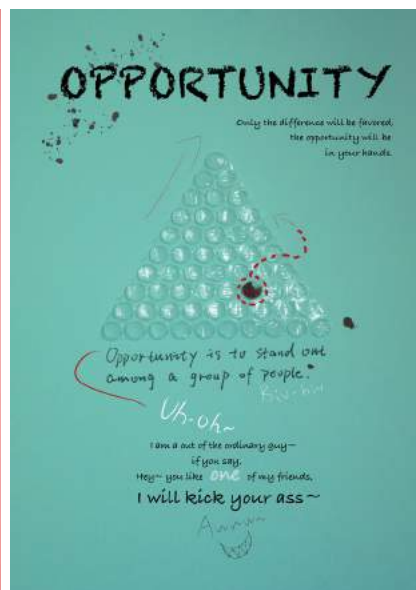
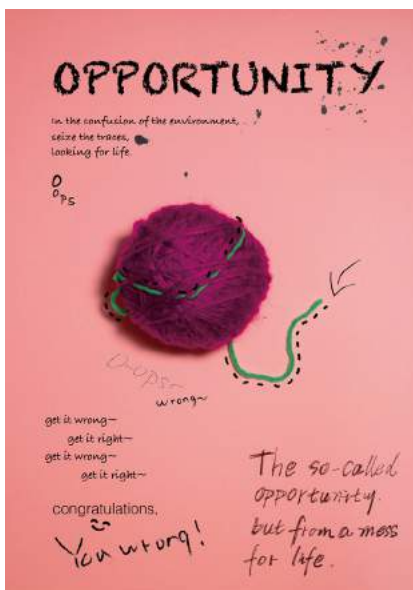

律動

Rhythm

作者姓名 Name of Designer(s)

羅金泉

Jin-Quan Luo

指導老師 Instructor(s)

李威

Wei Li

學校所在地 Location of School

中國大陸

China

學校名稱 Name of School

廣西藝術學院

Guangxi Arts Institute



週末孩子

Children at the Weekend

作者姓名 Name of Designer(s)

陳國利、梁文勝、吳寶渲

Guo-Li Chen, Wen-Sheng Liang,

Bao-Xuan Wu

指導老師 Instructor(s)

牛堯

Yao Niu

學校所在地 Location of School

中國大陸

China

學校名稱 Name of School

廣東轻工職業技術學院

Guangdong Industry Technical College

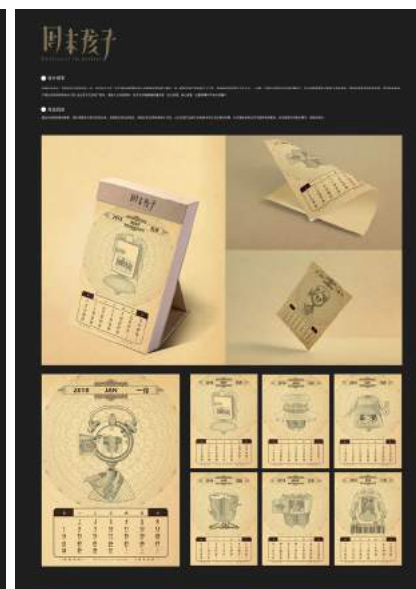
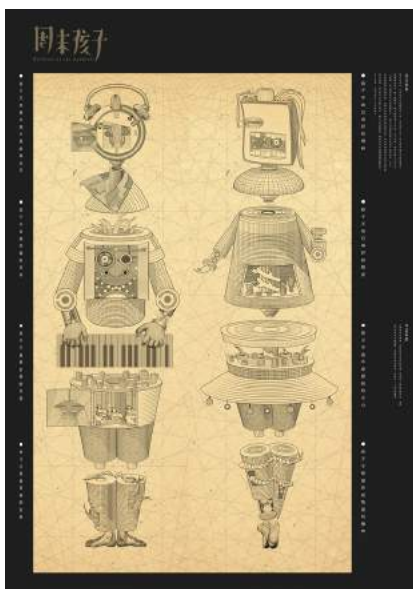



### 一紙簡歷

#### A Paper Resume

作者姓名 Name of Designer(s)

蒲倩

Qian Pu

指導老師 Instructor(s)

甘錦秀、李新富

Jin-Xiu Gan, Shin-Fu Lee

學校所在地 Location of School

中國大陸

China

學校名稱 Name of School

福州大學廈門工藝美術學院

Xiamen Academy of Arts and Design,  
Fuzhou University

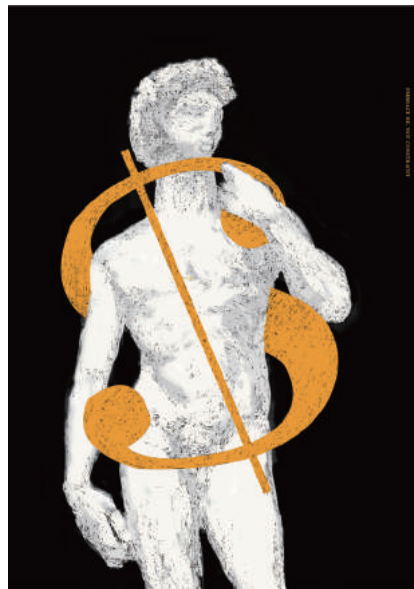

### Constraint

作者姓名 Name of Designer(s)

葉江風

Jiang-Feng Ye

指導老師 Instructor(s)

林俊良、劉建成、威躍春

Chun-Liang Lin, Jian-Cheng Liu,  
Yue-Chun Qi

學校所在地 Location of School

臺灣

Taiwan

學校名稱 Name of School

國立臺灣師範大學

National Taiwan Normal University



### Gone

作者姓名 Name of Designer(s)

葉江風

Jiang-Feng Ye

指導老師 Instructor(s)

威躍春、劉建成、林俊良

Yue-Chun Qi, Chien-Cheng Liu,  
Chun-Liang Lin

學校所在地 Location of School

臺灣

Taiwan

學校名稱 Name of School

國立臺灣師範大學

National Taiwan Normal University

## 害人終害己

### Ham Others Will Certainly Ham Himself

作者姓名 Name of Designer(s)

葉江風

Jiang-Feng Ye

指導老師 Instructor(s)

戚躍春、劉建成、林俊良

Yue-Chun Qi, Chien-Cheng Liu,  
Chun-Liang Lin

學校所在地 Location of School

臺灣

Taiwan

學校名稱 Name of School

國立臺灣師範大學

National Taiwan Normal University



## 慢性毒藥

### Chronic Poison

作者姓名 Name of Designer(s)

蘇國偉

Guo-Wei Su

指導老師 Instructor(s)

念凡、張明、李新富

Fan Nian, Ming Zhang, Shin-Fu Lee

學校所在地 Location of School

中國大陸

China

學校名稱 Name of School

福州大學廈門工藝美術學院

Xiamen Academy of Arts and Design, Fuzhou  
University

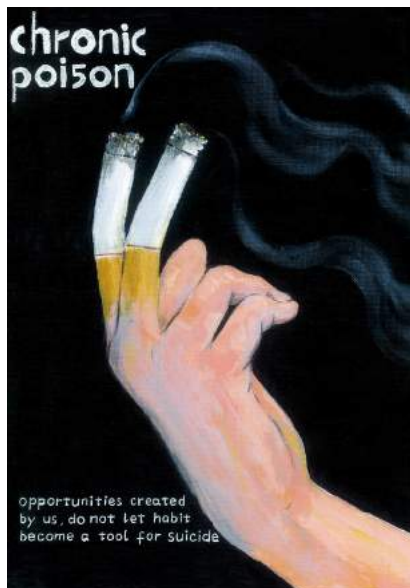



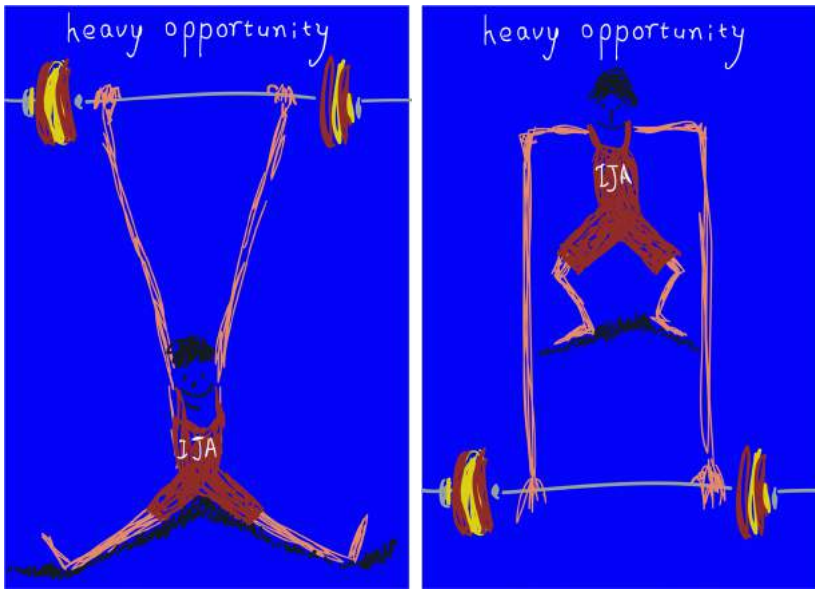

沉重的機會  
**Heavy Opportunity**

作者姓名 Name of Designer(s)

羅佳

Esabelle

指導老師 Instructor(s)

張大魯

Da-Lu Zhang

學校所在地 Location of School

中國大陸

China

學校名稱 Name of School

蘇州大學

Soochow University



缺  
**Gap**

作者姓名 Name of Designer(s)

魏昱江

Yu-Jiang Wei

指導老師 Instructor(s)

黃緝怡

Chen-I Huang

學校所在地 Location of School

臺灣

Taiwan

學校名稱 Name of School

南臺科技大學

Southern Taiwan University of Science and Technology



**MUSE**

作者姓名 Name of Designer(s)

紀雯萱、Zoe Lee Ning Xin

Boon-Syuen Kee, Zoe Lee Ning Xin

指導老師 Instructor(s)

Patrick Min

學校所在地 Location of School

馬來西亞

Malaysia

學校名稱 Name of School

吉隆坡萊佛士高等學院

Raffles College of Higher Education Kuala Lumpur

打破舒適區

**Break Through the Comfort Zone**

作者姓名 Name of Designer(s)  
 葉曉妮、王瑜斐、姚靜夜  
 Xiao-Ni Ye, Yu-Fei Wang, Jing-Ye Yao  
 指導老師 Instructor(s)  
 無  
 None  
 學校所在地 Location of School  
 中國大陸  
 China  
 學校名稱 Name of School  
 華東理工大學  
 East China University of Science and Technology



**Shinobatics**

作者姓名 Name of Designer(s)  
 Shin Yi Fong  
 指導老師 Instructor(s)  
 無  
 None  
 學校所在地 Location of School  
 馬來西亞  
 Malaysia  
 學校名稱 Name of School  
 吉隆坡萊佛士高等學院  
 Raffles College of Higher Education Kuala Lumpur

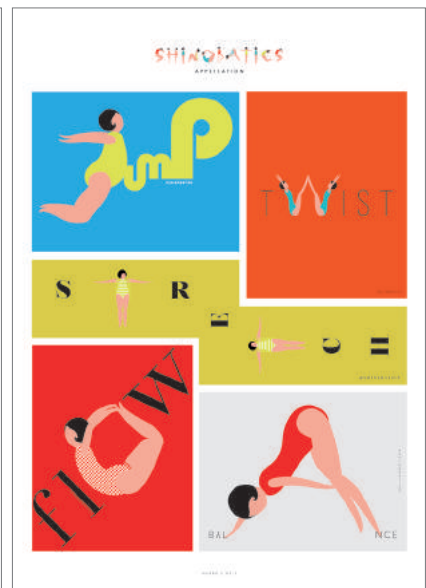
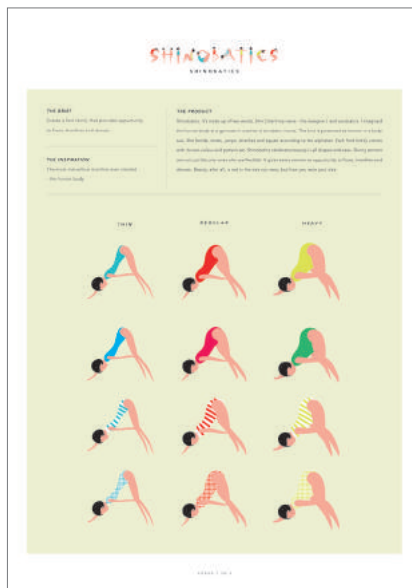

攀登

**None**

作者姓名 Name of Designer(s)  
 邱楚怡  
 Chu-Yi Qiu  
 指導老師 Instructor(s)  
 黃濤、念凡  
 Tao Huang, Fan Nian  
 學校所在地 Location of School  
 中國大陸  
 China  
 學校名稱 Name of School  
 福州大學廈門工藝美術學院  
 Xiamen Academy of Arts and Design, Fuzhou University

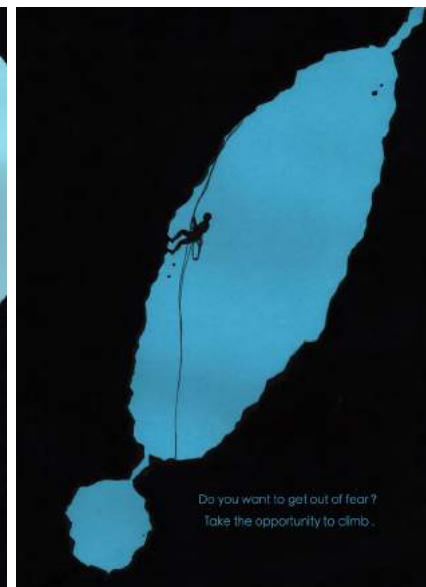



山有木兮  
The Mountain with Wood

作者姓名 Name of Designer(s)  
顏瑞  
Rui Yan  
指導老師 Instructor(s)  
何方  
Fang He  
學校所在地 Location of School  
中國大陸  
China  
學校名稱 Name of School  
南京藝術學院  
Nanjing University of the Arts



山有木兮  
The Mountain with Wood

作者姓名 Name of Designer(s)  
顏瑞  
Rui Yan  
指導老師 Instructor(s)  
何方  
Fang He  
學校所在地 Location of School  
中國大陸  
China  
學校名稱 Name of School  
南京藝術學院  
Nanjing University of the Arts



山海心境  
Sea and Mountain Mind

作者姓名 Name of Designer(s)  
邢佳惠  
Jia-Hui Xing  
指導老師 Instructor(s)  
李雙  
Shuang Li  
學校所在地 Location of School  
中國大陸  
China  
學校名稱 Name of School  
福州大學廈門工藝美術學院  
Xiamen Academy of Arts and Design,  
Fuzhou University



湮滅

Annihilation

作者姓名 Name of Designer(s)

易濤

Tao Yi

指導老師 Instructor(s)

陳小林、許亮

Xiao-Lin Chen, Liang Xu

學校所在地 Location of School

中國大陸

China

學校名稱 Name of School

四川大學

Sichuan University

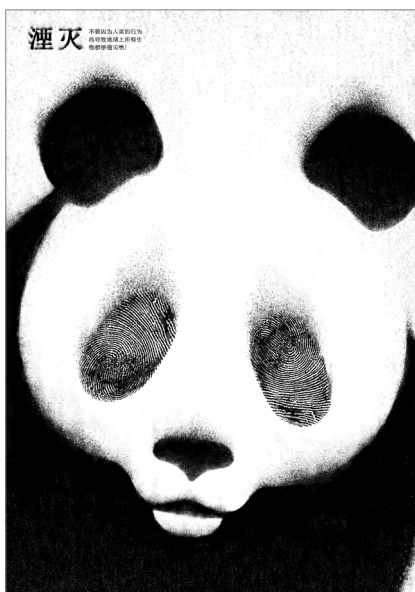

"壹字百生" 文化創意館

"One Word, Hundred Lives"  
Culture and Creative Pavilion  
(Brand Design)

作者姓名 Name of Designer(s)

王琬惠

Wan-Hui Wang

指導老師 Instructor(s)

張曉東

Xiao-Dong Zhang

學校所在地 Location of School

中國大陸

China

學校名稱 Name of School

北京印刷學院

Beijing Institute of Graphic Communication



造海說

Theory of Creation of the Sea

作者姓名 Name of Designer(s)

鐘雲蝶

Yun-Die Zhong

指導老師 Instructor(s)

夏輝璘

Hui-Lin Xia

學校所在地 Location of School

中國大陸

China

學校名稱 Name of School

廣西藝術學院

Guangxi Arts Institute



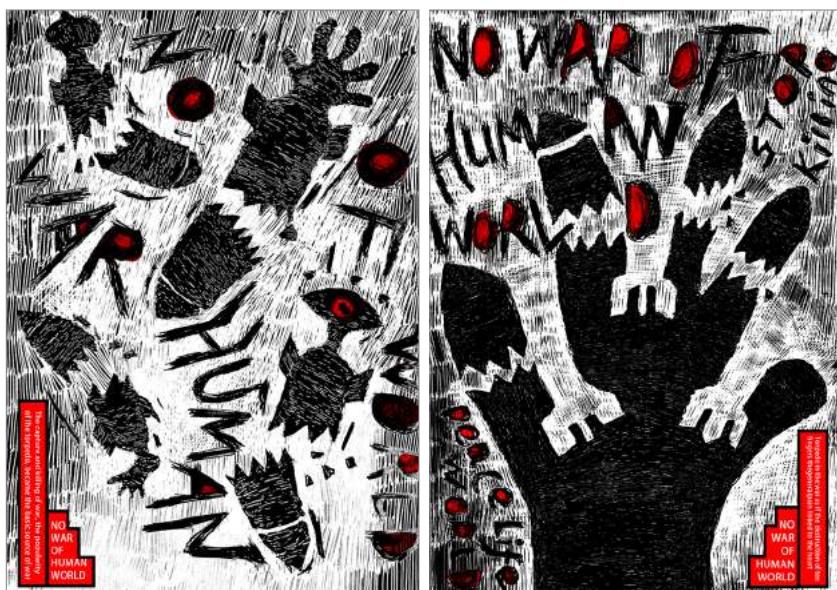

### 無戰的人類世界 No War of Human World

作者姓名 Name of Designer(s)

鐘雲蝶

Yun-Die Zhong

指導老師 Instructor(s)

李威

Wei Li

學校所在地 Location of School

中國大陸

China

學校名稱 Name of School

廣西藝術學院

Guangxi Arts Institute



### 炭象

#### Carbonization Series Works

作者姓名 Name of Designer(s)

陳爽爽

Shuang-Shuang Chen

指導老師 Instructor(s)

無

None

學校所在地 Location of School

中國大陸

China

學校名稱 Name of School

山東藝術學院

Shandong University of Arts



### 吉祥畫字

#### Auspicious Characters

作者姓名 Name of Designer(s)

梁良

Liang Liang

指導老師 Instructor(s)

黃宗湖

Zong-Hu Huang

學校所在地 Location of School

中國大陸

China

學校名稱 Name of School

廣西藝術學院

Guangxi Arts Institute



## 生存即是機會

### Survive Is a Chance

作者姓名 Name of Designer(s)

莊琬筑

Wan-Zhu Zhuang

指導老師 Instructor(s)

趙飛帆

Fei-Fan Chao

學校所在地 Location of School

臺灣

Taiwan

學校名稱 Name of School

國立雲林科技大學

National Yunlin University of Science and Technology



## 女權

### Women's Rights

作者姓名 Name of Designer(s)

李東東

Dan-Ton Lee

指導老師 Instructor(s)

張文化、戚躍春

Wen-Hua Zhang, Yue-Chun Qi

學校所在地 Location of School

中國大陸

China

學校名稱 Name of School

廈門大學

Xiamen University



## 未末

### Not the End

作者姓名 Name of Designer(s)

賈哈朔

Han-Shuo Jia

指導老師 Instructor(s)

吳軼博

Yi-Bo Wu

學校所在地 Location of School

中國大陸

China

學校名稱 Name of School

吉林藝術學院

Jilin University of the Arts





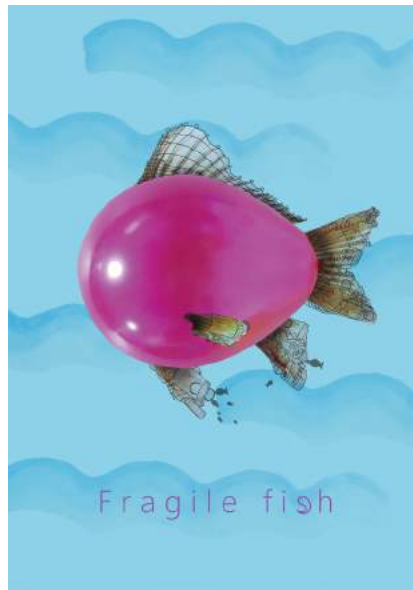

給他們一個機會  
**Give Them a Chance**

作者姓名 Name of Designer(s)

葉年惠

Nian-Hui Ye

指導老師 Instructor(s)

江耀順、李佳鴻

Yaw-Shuen Jiang, Chia-Hung Lee

學校所在地 Location of School

臺灣

Taiwan

學校名稱 Name of School

私立復興高級商工職業學校

Fu-Hsin Trade & Arts School



跑  
**Run**

作者姓名 Name of Designer(s)

蘇芳玉

Fang-Yu Su

指導老師 Instructor(s)

李子庭、徐慧君

Zi-Ting Li, Hui-Jun Xu

學校所在地 Location of School

臺灣

Taiwan

學校名稱 Name of School

私立復興高級商工職業學校

Fu-Hsin Trade & Arts School

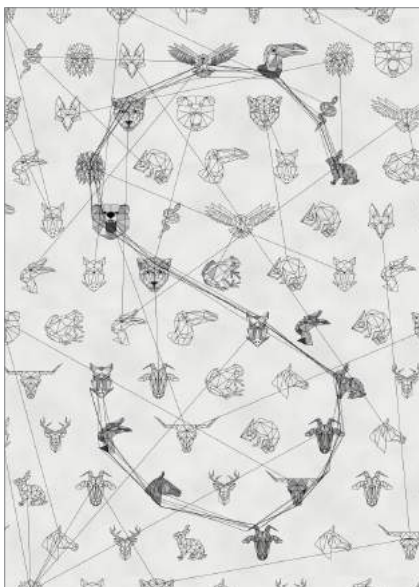

創造機會是生存的意志  
**Creating Opportunity Is the Will to Survive**

作者姓名 Name of Designer(s)

陳偉駿

Vui-Jun Chin

指導老師 Instructor(s)

Aini Nazihah Abu Bakar

學校所在地 Location of School

馬來西亞

Malaysia

學校名稱 Name of School

馬來西亞藝術學院

Malaysian Institute of Art

機遇時代

The Age of Opportunity

作者姓名 Name of Designer(s)

劉璿

Xuan Liu

指導老師 Instructor(s)

黃穎宜

Ying-Yi Huang

學校所在地 Location of School

中國大陸

China

學校名稱 Name of School

中國計量大學

China Jiliang Univeristy

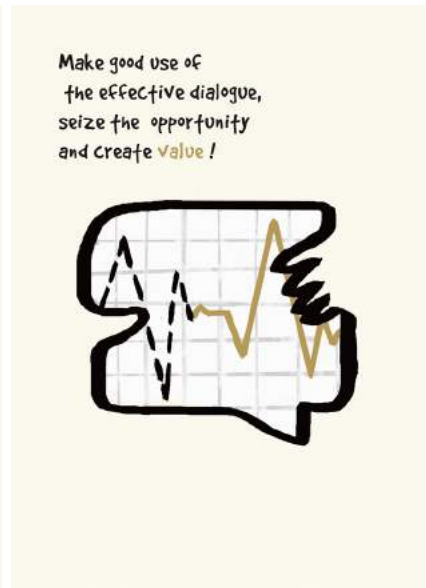

A Click That Matters

作者姓名 Name of Designer(s)

Kartini

指導老師 Instructor(s)

無

None

學校所在地 Location of School

新加坡

Singapore

學校名稱 Name of School

萊佛士高等教育學院

Raffles College for Higher Education



交流創造機遇

Exchange to Create Opportunities

作者姓名 Name of Designer(s)

岳雲霄

Yun-Xiao Yue

指導老師 Instructor(s)

戚躍春、林磐聳

Yue-Chun Qi, Pang-Soong Lin

學校所在地 Location of School

中國大陸

China

學校名稱 Name of School

廈門大學

Xiamen University

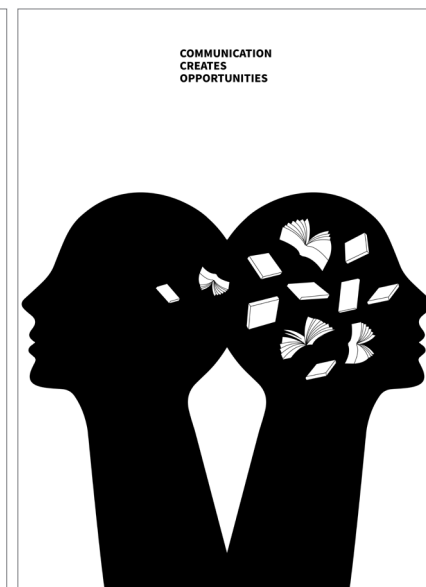
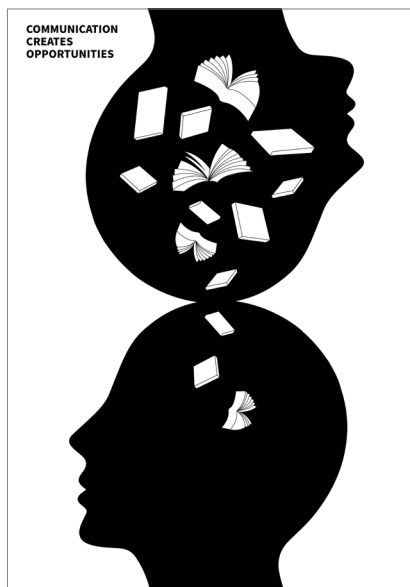



健康生活

Healthy Lifestyle

作者姓名 Name of Designer(s)

岳雲霄、王慧芳  
Yun-Xiao Yue, Hui-Fang Wang

指導老師 Instructor(s)

戚躍春、張文化  
Yue-Chun Qi, Wen-Hua Zhang

學校所在地 Location of School

中國大陸  
China

學校名稱 Name of School

廈門大學  
Xiamen University

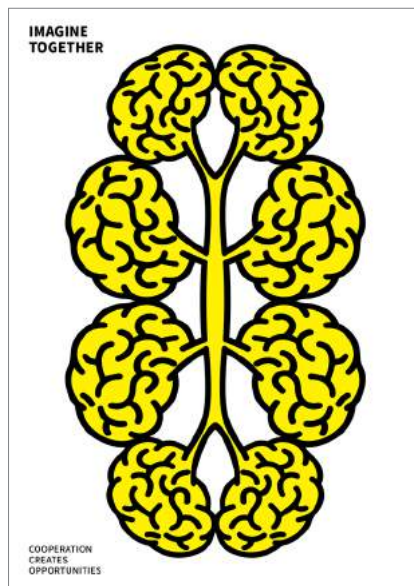
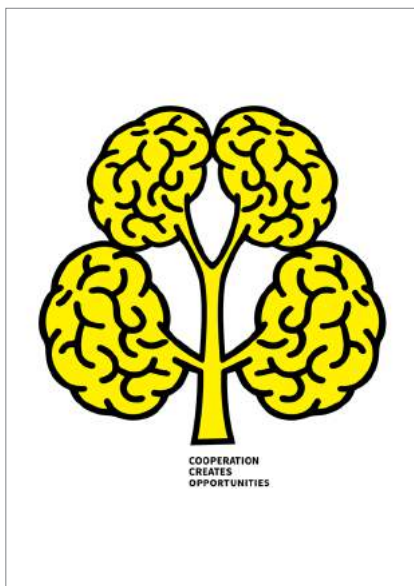

思想的生命力

The Vitality of Thought

作者姓名 Name of Designer(s)

岳雲霄  
Yun-Xiao Yue

指導老師 Instructor(s)

戚躍春、林磐聳  
Yue-Chun Qi, Pang-Soong Lin

學校所在地 Location of School

中國大陸  
China

學校名稱 Name of School

廈門大學  
Xiamen University



嗶！

Beep!

作者姓名 Name of Designer(s)

吳佳錡  
Jia-Chi Wu

指導老師 Instructor(s)

無  
None

學校所在地 Location of School

臺灣  
Taiwan

學校名稱 Name of School

致理科技大學  
Chihlee University of Technology



海中瓶子 瓶中悲劇

**On Plastico Battle in the Sea, One Life in the Pain.**

作者姓名 Name of Designer(s)

黃妍晴

Yan-Qing Huang

指導老師 Instructor(s)

費國鏡、李佳珍

Guo-Jing Fei, Jia-Zhen Li

學校所在地 Location of School

臺灣

Taiwan

學校名稱 Name of School

臺北市立士林高級商業職業學校

Taipei Municipal Shilin High School of Commerce

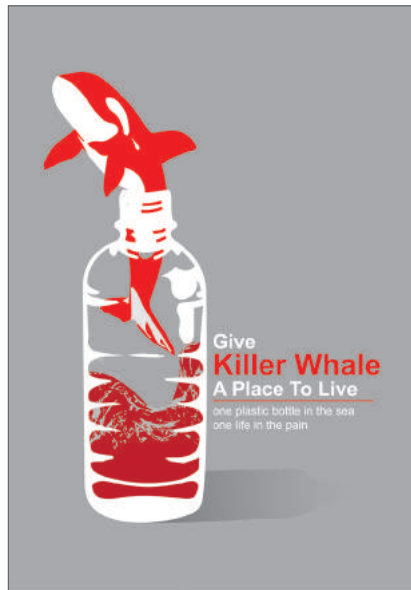

地球的主人

**Masters of the Earth**

作者姓名 Name of Designer(s)

王飛飛、潘芋汐

Fei-Fei Wang, Yu-Xi Pan

指導老師 Instructor(s)

許亮

Liang-Xu

學校所在地 Location of School

中國大陸

China

學校名稱 Name of School

四川大學

Sichuan University



**Theatrical Posters**

作者姓名 Name of Designer(s)

Tatiana Laponkina

指導老師 Instructor(s)

Boris Trofimov, Alexey Veselovskiy

學校所在地 Location of School

俄羅斯

Russia

學校名稱 Name of School

商業與設計學院

Institute of Business and Design

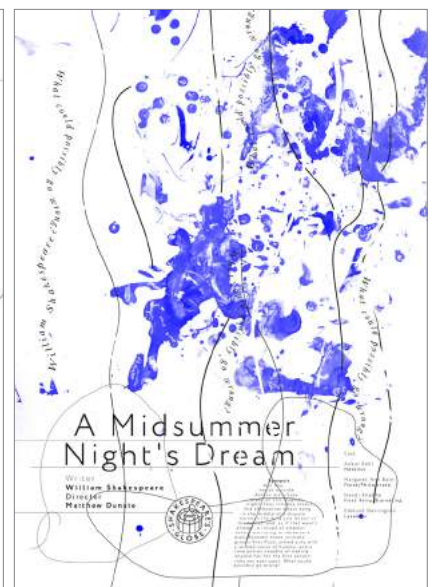
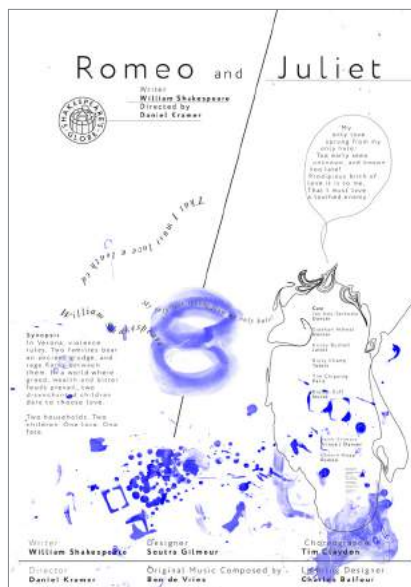



### 智慧海洋系列

#### Ocean Wise

作者姓名 Name of Designer(s)

楊庚明、徐愷辰

Geng-Ming Yang, Kai-Chen Xu

指導老師 Instructor(s)

楊開敏、董婉婷、易曉蜜

Kai-Ming Yang, Wan-Ting Dong,  
Xiao-Mi Yi

學校所在地 Location of School

中國大陸

China

學校名稱 Name of School

四川音樂學院成都美術學院

Chengdu Academy of Fine Arts



### 只要情緒

#### Only Emotion

作者姓名 Name of Designer(s)

肖瑤

Yao Xiao

指導老師 Instructor(s)

吳煒晨

Wei-Chen Wu

學校所在地 Location of School

中國大陸

China

學校名稱 Name of School

中國美術學院

China Academy of Art



### Never Escape an "Opportunity"

作者姓名 Name of Designer(s)

Mukund Choudhary

指導老師 Instructor(s)

無

None

學校所在地 Location of School

印度

India

學校名稱 Name of School

國家時裝技術學院 (布巴內什瓦爾)

National Institute of Fashion Technology,  
Bhubaneswar

下一秒？

**The Next Second?**

作者姓名 Name of Designer(s)

高小詩

Xiao-Shi Gao

指導老師 Instructor(s)

無

None

學校所在地 Location of School

臺灣

Taiwan

學校名稱 Name of School

國立交通大學

National Chiao Tung University



**Opportunity Is the of Life**

作者姓名 Name of Designer(s)

Souksun Daungxay

指導老師 Instructor(s)

Souliya Phoumivong

學校所在地 Location of School

寮國

Lao

學校名稱 Name of School

國立美術學院

National Institute of Fine Art



守護

**Guard**

作者姓名 Name of Designer(s)

劉英君

Ying-Jun Liu

指導老師 Instructor(s)

張文化

Wen-Hua Zhang

學校所在地 Location of School

中國大陸

China

學校名稱 Name of School

廈門大學

Xiamen University

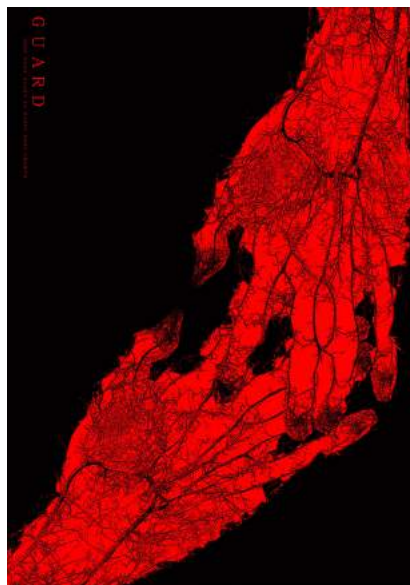



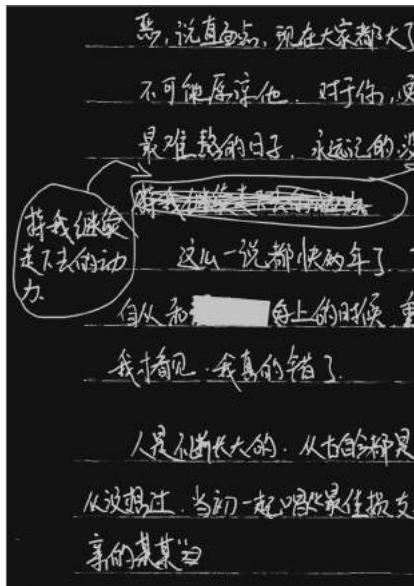

### Opportunity

作者姓名 Name of Designer(s)

徐雪

Xue Xu

指導老師 Instructor(s)

念凡

Fan Nian

學校所在地 Location of School

中國大陸

China

學校名稱 Name of School

福州大學廈門工藝美術學院

Xiamen Academy of Arts and Design, Fuzhou University

### 和他們的七十七封信

#### The Seventy-Seven Letters with Them

作者姓名 Name of Designer(s)

霍馨然

Xin-Ran Huo

指導老師 Instructor(s)

熊文飛、張禹

Wen-Fei Xiong, Yu Zhang

學校所在地 Location of School

中國大陸

China

學校名稱 Name of School

武漢理工大學

Wuhan University of Technology



### Poster Design

#### "Likes Don't Save Life"

作者姓名 Name of Designer(s)

Le Nguyen Hoai Trung

指導老師 Instructor(s)

David Foo

學校所在地 Location of School

新加坡

Singapore

學校名稱 Name of School

第一媒體設計學院

First Media Design School

### Daily Junk Mail

作者姓名 Name of Designer(s)

Sixin Chen

指導老師 Instructor(s)

Pablo Delcan

學校所在地 Location of School

美國

United States of America

學校名稱 Name of School

紐約視覺藝術學院

School of Visual Arts

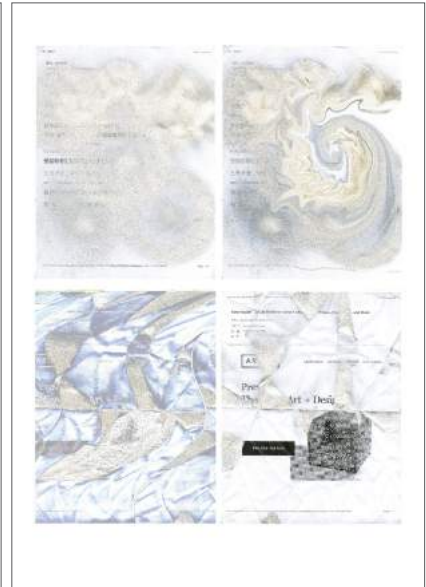

### Tu9 Institutes of Technology

作者姓名 Name of Designer(s)

Grina Choi

指導老師 Instructor(s)

Paula Scher, Courtney Gooch

學校所在地 Location of School

美國

United States of America

學校名稱 Name of School

紐約視覺藝術學院

School of Visual Arts



### Museum of Contemporary Art Cleveland

作者姓名 Name of Designer(s)

Grina Choi

指導老師 Instructor(s)

Paula Scher, Courtney Gooch

學校所在地 Location of School

美國

United States of America

學校名稱 Name of School

紐約視覺藝術學院

School of Visual Arts

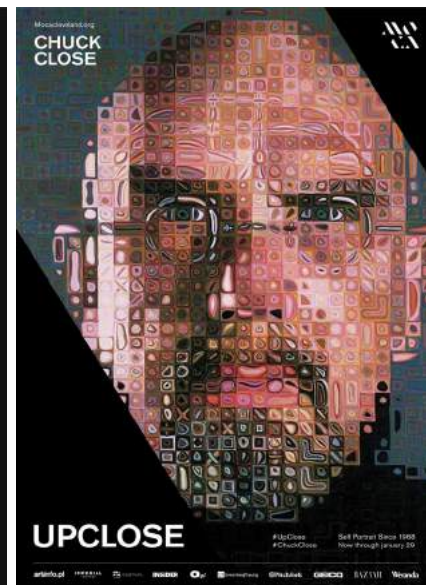

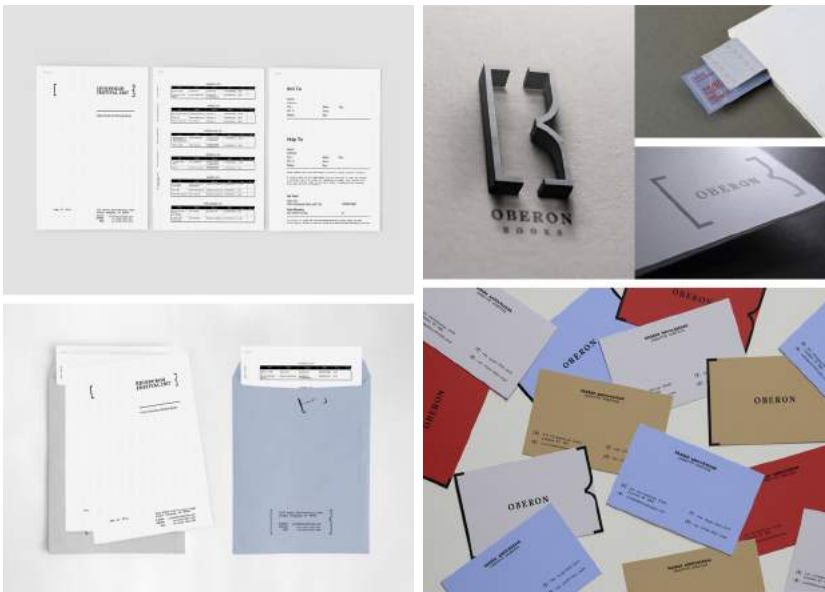

### Oberon Books

作者姓名 Name of Designer(s)

Grina Choi

指導老師 Instructor(s)

Paula Scher, Courtney Gooch

學校所在地 Location of School

美國

United States of America

學校名稱 Name of School

紐約視覺藝術學院

School of Visual Arts



### Wild Dedication

作者姓名 Name of Designer(s)

Grina Choi

指導老師 Instructor(s)

Scott Buschkuhl

學校所在地 Location of School

美國

United States of America

學校名稱 Name of School

紐約視覺藝術學院

School of Visual Arts



### 啼嘯

### To Roar

作者姓名 Name of Designer(s)

張朔豪

Shuo-Hao Chang

指導老師 Instructor(s)

李子庭

Zi-Ting Li

學校所在地 Location of School

臺灣

Taiwan

學校名稱 Name of School

私立復興高級商工職業學校

Fu-Hsin Trade & Arts School



### Knowledge Is Power

作者姓名 Name of Designer(s)

劉燦、申昕

Shuo Liu, Xin Shen

指導老師 Instructor(s)

王剛

Gang Wang

學校所在地 Location of School

中國大陸

China

學校名稱 Name of School

山東工藝美術學院

Shandong University of Art & Design



### It All Starts with a Smile

作者姓名 Name of Designer(s)

Paola Chen Li

指導老師 Instructor(s)

無

None

學校所在地 Location of School

美國

United States of America

學校名稱 Name of School

薩凡納藝術與設計學院

Savannah College of Art and Design



### 握

#### Shake Hands

作者姓名 Name of Designer(s)

張栗蓁

Li-Zhen Zhang

指導老師 Instructor(s)

宋思明

Si-Zhi Song

學校所在地 Location of School

臺灣

Taiwan

學校名稱 Name of School

嶺東科技大學

Ling Tung University





機會

**Opportunity**

作者姓名 Name of Designer(s)

符音

Yin Fu

指導老師 Instructor(s)

無

None

學校所在地 Location of School

澳洲

Australia

學校名稱 Name of School

蒙納士大學

Monash University

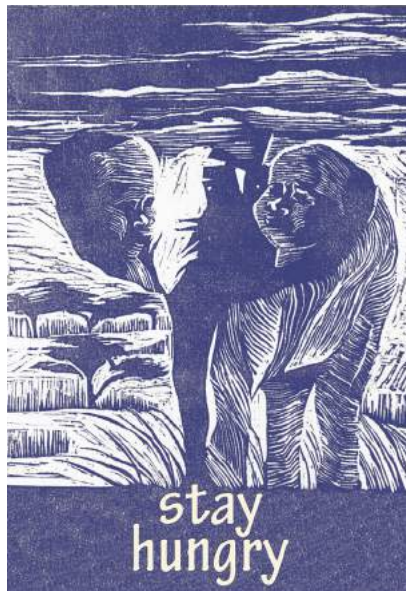
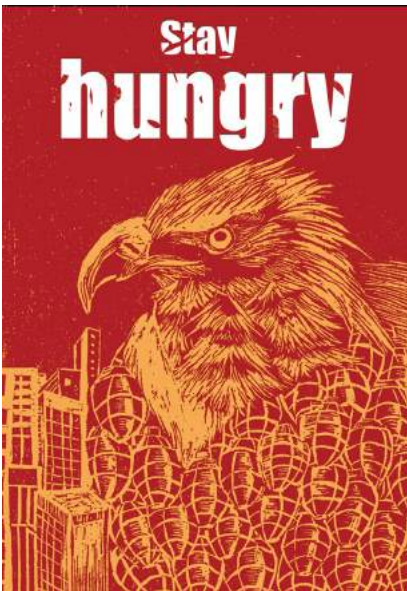

飢餓 / 飢渴

**Stay Hungry**

作者姓名 Name of Designer(s)

陳葶瑀

Ting-Yu Chen

指導老師 Instructor(s)

劉建成

Chien-Cheng Liu

學校所在地 Location of School

臺灣

Taiwan

學校名稱 Name of School

國立臺灣師範大學

National Taiwan Normal University



我

**Me**

作者姓名 Name of Designer(s)

黃向敏

Xiang-Min Huang

指導老師 Instructor(s)

張文化

Wen-Hua Zhang

學校所在地 Location of School

中國大陸

China

學校名稱 Name of School

廈門大學

Xiamen University

## 鯨魚

### Whale

作者姓名 Name of Designer(s)

楊碧君

Bi-Jun Yang

指導老師 Instructor(s)

張明、李新富

Ming Zhang, Shin-Fu Lee

學校所在地 Location of School

中國大陸

China

學校名稱 Name of School

福州大學廈門工藝美術學院

Xiamen Academy of Arts and Design, Fuzhou

University



## 《言論暴力》

### 《Language Violence》

作者姓名 Name of Designer(s)

于越

Yue Yu

指導老師 Instructor(s)

黃志雄、李雙

Zhi-Xiong Huang, Shuang Lee

學校所在地 Location of School

中國大陸

China

學校名稱 Name of School

福州大學廈門工藝美術學院

Xiamen Academy of Arts and Design, Fuzhou

University

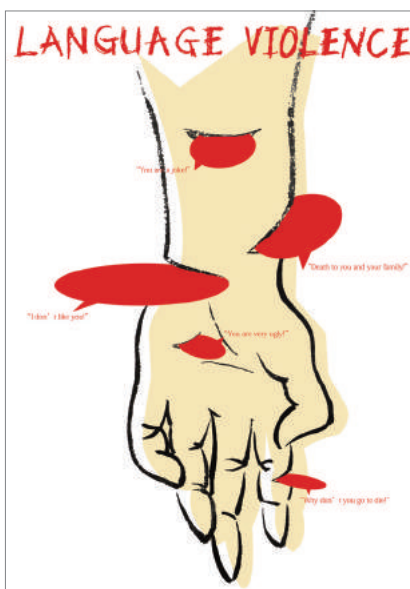

## 奉獻的力量

### Power of Devotion

作者姓名 Name of Designer(s)

蘇國偉

Guo-Wei Su

指導老師 Instructor(s)

念凡、張明、李新富

Fan Nian, Ming Zhang, Shin-Fu Lee

學校所在地 Location of School

中國大陸

China

學校名稱 Name of School

福州大學廈門工藝美術學院

Xiamen Academy of Arts and Design, Fuzhou

University





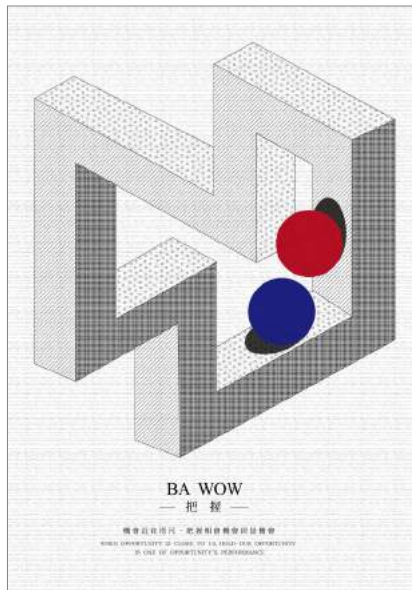
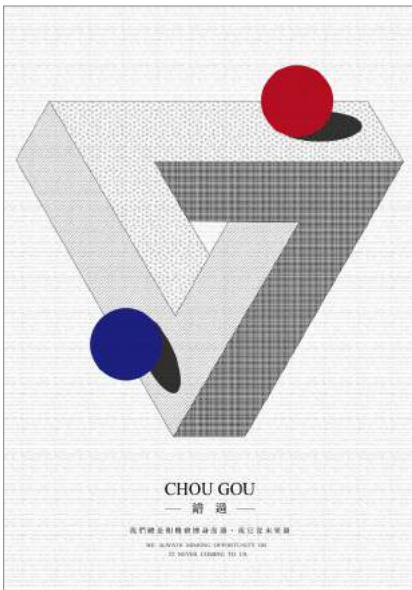

機會，亦是生命中的情人

**Opportunity is also the Lover of Life**

作者姓名 Name of Designer(s)

馬德承

Dee-Chang Ma

指導老師 Instructor(s)

鄭中義

Jhong-Yi Jheng

學校所在地 Location of School

臺灣

Taiwan

學校名稱 Name of School

崑山科技大學

Kun Shan University



抓

**Catch**

作者姓名 Name of Designer(s)

劉豫鐸、李龔瀚藝

Yu-Duo Liu, Han Yi Li Gong

指導老師 Instructor(s)

無

None

學校所在地 Location of School

中國大陸

China

學校名稱 Name of School

福州大學廈門工藝美術學院

Xiamen Academy of Arts and Design,  
Fuzhou University



《閱讀之美》系列

**"Reading Beauty" Series**

作者姓名 Name of Designer(s)

周成寶

Cheng-Bao Zhou

指導老師 Instructor(s)

馬泉

Quan Ma

學校所在地 Location of School

中國大陸

China

學校名稱 Name of School

中國藝術研究院

China Art Research Institute

自然生命安全  
Nature, Life, Safety

作者姓名 Name of Designer(s)  
劉英君  
Ying-Jun Liu

指導老師 Instructor(s)  
張文化  
Wen-Hua Zhang

學校所在地 Location of School  
中國大陸  
China

學校名稱 Name of School  
廈門大學  
Xiamen University



點觸  
Touch

作者姓名 Name of Designer(s)  
劉英君  
Ying-Jun Liu

指導老師 Instructor(s)  
張文化  
Wen-Hua Zhang

學校所在地 Location of School  
中國大陸  
China

學校名稱 Name of School  
廈門大學  
Xiamen University

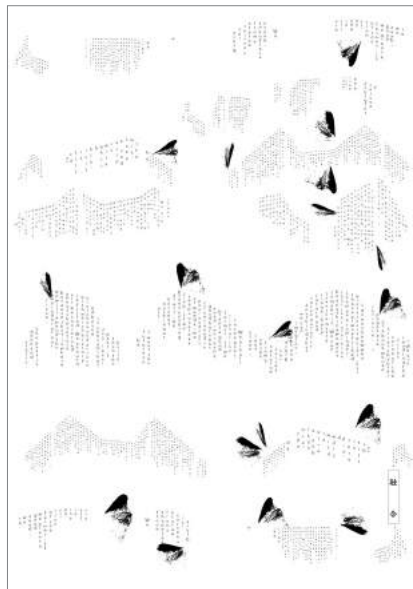

Wanderer Space Program-  
Paper Swatch

作者姓名 Name of Designer(s)  
Nina Suraya  
Fiyon Neau

指導老師 Instructor(s)  
張文化  
Wen-Hua Zhang

學校所在地 Location of School  
馬來西亞  
Malaysia

學校名稱 Name of School  
吉隆坡萊佛士高等學院  
Raffles College of Higher Education Kuala Lumpur

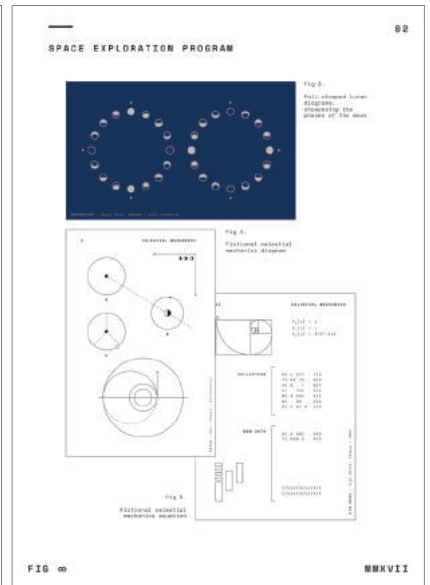
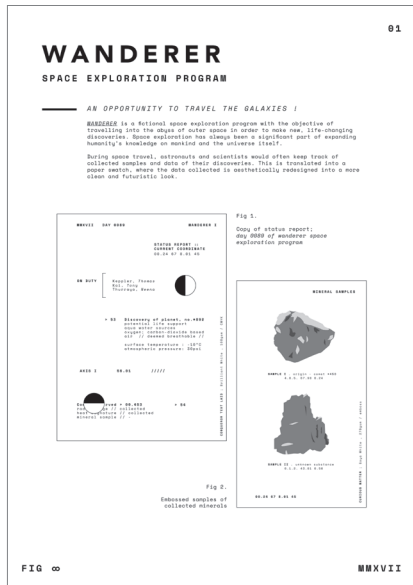



### 智慧海洋

## The Opportunity of the Sea of Wisdom

作者姓名 Name of Designer(s)

李文

Wen Li

指導老師 Instructor(s)

許亮

Liang Xu

學校所在地 Location of School

中國大陸

China

學校名稱 Name of School

四川大學

Sichuan University



### 鐵杵也能磨成繡花針

## Maker Hub Studio

作者姓名 Name of Designer(s)

陳仕宏

Shi-Hong Chen

指導老師 Instructor(s)

郭中元

Chung-Yuan Kuo

學校所在地 Location of School

臺灣

Taiwan

學校名稱 Name of School

嶺東科技大學

Ling Tung University

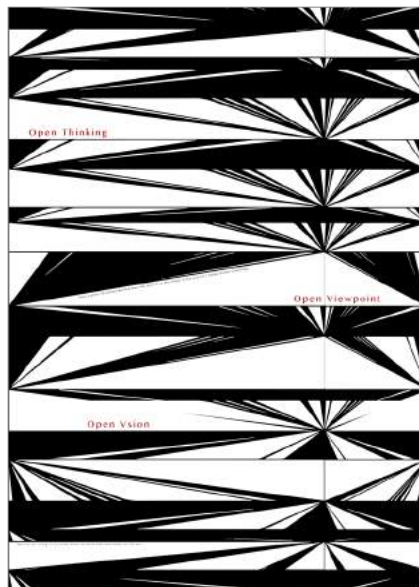

### 姓名密碼

## Name Password

作者姓名 Name of Designer(s)

劉英君

Ying-Jun Liu

指導老師 Instructor(s)

張文化

Wen-Hua Zhang

學校所在地 Location of School

中國大陸

China

學校名稱 Name of School

廈門大學

Xiamen University



## 上鎖

### Lock

作者姓名 Name of Designer(s)

劉英君

Ying-Jun Liu

指導老師 Instructor(s)

張文化

Wen-Hua Zhang

學校所在地 Location of School

中國大陸

China

學校名稱 Name of School

廈門大學

Xiamen University

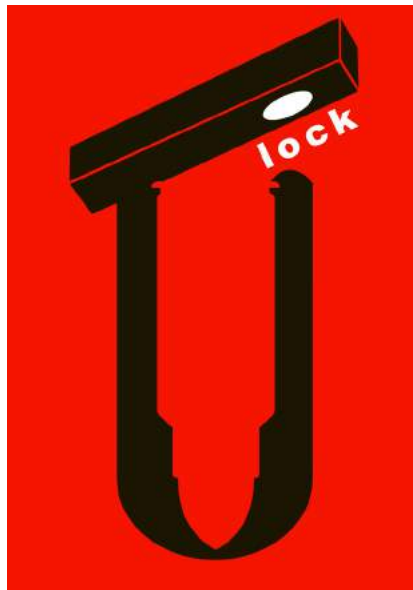

## 挽住最後的生機

### Take the Last Chance

作者姓名 Name of Designer(s)

柳毅鴻

Jordan Liu

指導老師 Instructor(s)

許亮

Liang Xu

學校所在地 Location of School

中國大陸

China

學校名稱 Name of School

四川大學

Sichuan University

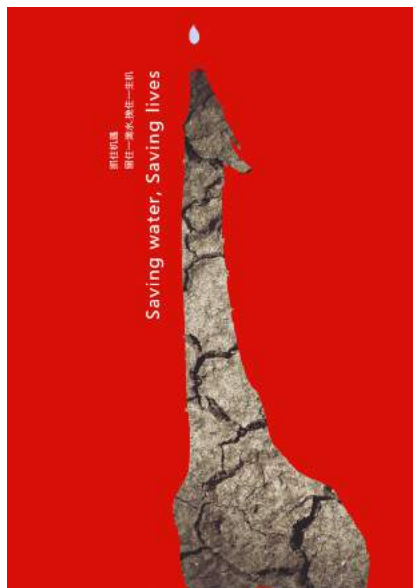

## World Lover

作者姓名 Name of Designer(s)

Anulath Souninmavong

指導老師 Instructor(s)

Thanousone Vongpraseuth

學校所在地 Location of School

寮國

Lao

學校名稱 Name of School

寮國國立大學

National University of Laos



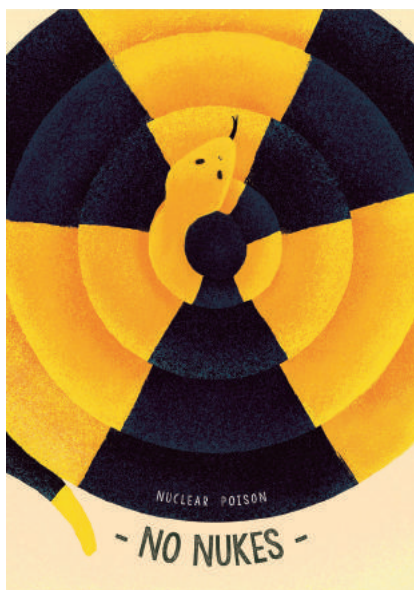

### No Nukes

作者姓名 Name of Designer(s)

李佩娟

Pei-Chuan Li

指導老師 Instructor(s)

林俊良

Chun-Laing Lin

學校所在地 Location of School

臺灣

Taiwan

學校名稱 Name of School

國立高雄師範大學

National Kaohsiung Normal University



### 吉祥的輪回 -

### 藏密十二生肖插圖設計

### The Reincarnation of Auspiciousness - An Opportunity for Han and Tibetan Cultures

作者姓名 Name of Designer(s)

陳堅、羅婉月、居蘇晉

Jian Chen, Wan-Yue Luo, Su-Jin Ju

指導老師 Instructor(s)

王莉莉、許亮

Li-Li Wang, Liang Xu

學校所在地 Location of School

中國大陸

China

學校名稱 Name of School

四川大學

Sichuan University



### 《福祿壽？》系列海報

### 《Good Fortune, Prosperity, Longevity》

作者姓名 Name of Designer(s)

謝自潔

Zi-Jie Xie

指導老師 Instructor(s)

李少波

Shao-Bo Li

學校所在地 Location of School

中國大陸

China

學校名稱 Name of School

湖南師範大學

Hunan Normal University

無

### Autism

作者姓名 Name of Designer(s)

金典

Dian Jin

指導老師 Instructor(s)

無

None

學校所在地 Location of School

中國大陸

China

學校名稱 Name of School

四川大學

Sichuan University



### Lets Not Lose Our Opportunity- " Getting Nowhere "

作者姓名 Name of Designer(s)

Ananthakrishnan Balasubramanian

指導老師 Instructor(s)

無

None

學校所在地 Location of School

印度

India

學校名稱 Name of School

國立設計學院

National Institute of Design



### 停止言語暴力

### Stop Verbal Violence

作者姓名 Name of Designer(s)

黃睦軒

Mu-Xuan Huang

指導老師 Instructor(s)

楊肇傳

Zhao-Pi Yang

學校所在地 Location of School

臺灣

Taiwan

學校名稱 Name of School

樹德科技大學

Shu-Te University

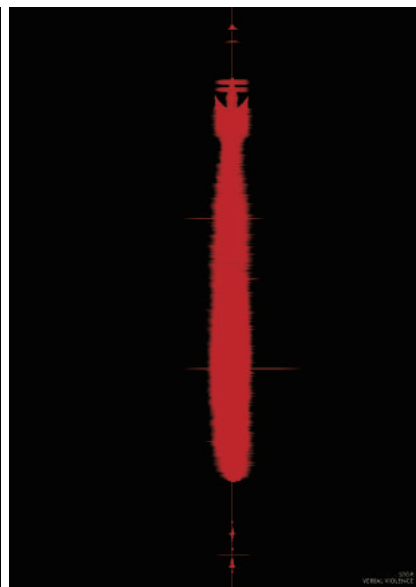
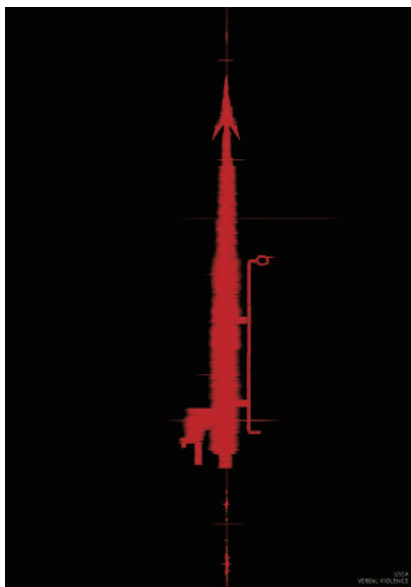





### I Am What I Am

作者姓名 Name of Designer(s)

Shin Yi Fong

指導老師 Instructor(s)

無

None

學校所在地 Location of School

馬來西亞

Malaysia

學校名稱 Name of School

吉隆坡萊佛士高等學院

Raffles College of Higher Education Kuala Lumpur

Lumpur



### 排斥

#### Exclusion

作者姓名 Name of Designer(s)

鄭怡君

Yi-Jyun Jheng

指導老師 Instructor(s)

游明龍

Ming-Lung Yu

學校所在地 Location of School

臺灣

Taiwan

學校名稱 Name of School

亞洲大學

Asia University

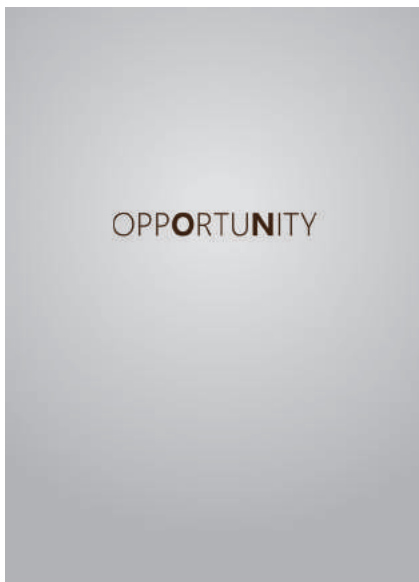

### 繼續

#### Go On

作者姓名 Name of Designer(s)

宋少華

Shao-Hua Song

指導老師 Instructor(s)

無

None

學校所在地 Location of School

中國大陸

China

學校名稱 Name of School

天津商業大學

Tianjin University of Commerce



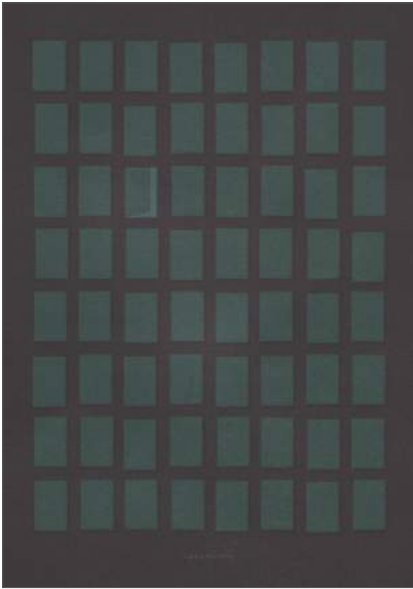

### 發現

#### Found

作者姓名 Name of Designer(s)

高筱婷

Hsiao-Ting Kao

指導老師 Instructor(s)

無

None

學校所在地 Location of School

臺灣

Taiwan

學校名稱 Name of School

國立臺北商業大學

National Taipei University of Business



### 框架世界

#### Framework World

作者姓名 Name of Designer(s)

吳振宇

Zhen-Yu Wu

指導老師 Instructor(s)

趙飛帆

Fei-Fan Chao

學校所在地 Location of School

臺灣

Taiwan

學校名稱 Name of School

國立雲林科技大學

National Yunlin University of Science and Technology



### 打花

#### Tujia Brocade

作者姓名 Name of Designer(s)

謝宇、伍志萍、張燕軍

Yu Xie, Zhi-Ping Wu, Yan-Jun Zhang

指導老師 Instructor(s)

吳綺虹

Qi-Hong Wu

學校所在地 Location of School

中國大陸

China

學校名稱 Name of School

仲愷農業工程學院

Zhongkai University of Agriculture and Engineering



## 深海遠洋

### Deep Sea and Vast Ocean

作者姓名 Name of Designer(s)

劉怡利

Yi-Li Liu

指導老師 Instructor(s)

李娟

Jenny Lee

學校所在地 Location of School

中國大陸

China

學校名稱 Name of School

廣西藝術學院

Guangxi Arts Institute



## Ocean Pollution

作者姓名 Name of Designer(s)

黃振興、趙子策、劉丹

Zhen-Xing Huang, Zi-Ce Zhao, Dan Liu

指導老師 Instructor(s)

李威

Wei Lee

學校所在地 Location of School

中國大陸

China

學校名稱 Name of School

廣西藝術學院

Guangxi Arts Institute



## 紙相

### The Implication of Paper

作者姓名 Name of Designer(s)

袁興龍

Hsing-Lung Yuan

指導老師 Instructor(s)

無

None

學校所在地 Location of School

中國大陸

China

學校名稱 Name of School

四川美術學院

Sichuan Fine Arts Institute

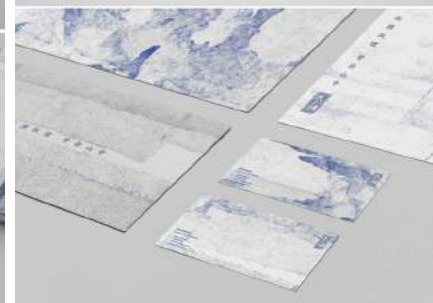
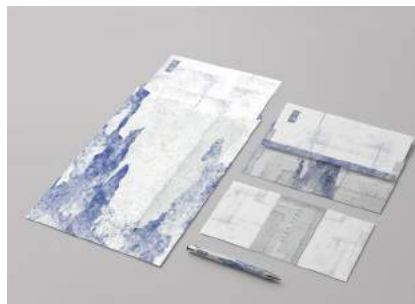

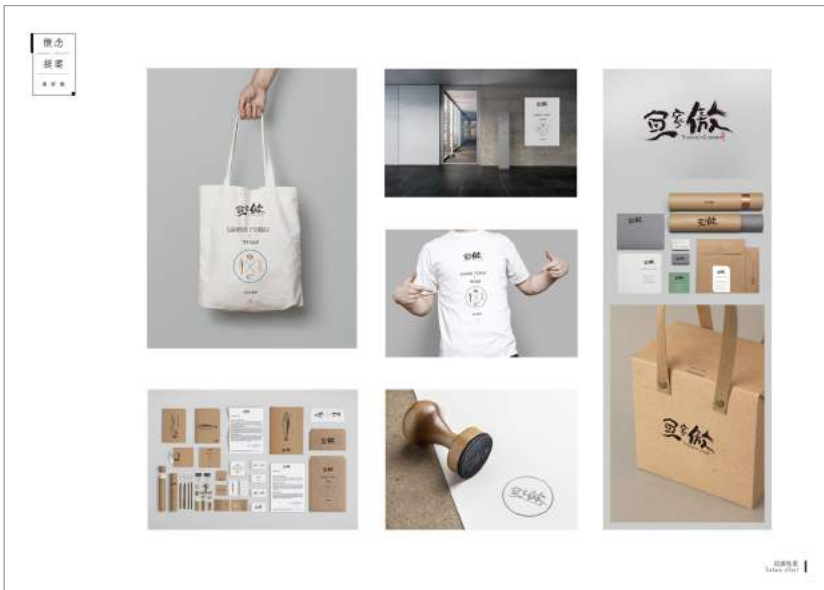

《魚家傲》海產品乾貨包裝  
Fishing Pride Marine Product  
- Packaging Design

作者姓名 Name of Designer(s)

黃益鑾

Yi-Luan Huang

指導老師 Instructor(s)

無

None

學校所在地 Location of School

中國大陸

China

學校名稱 Name of School

杭州電子科技大學

Hangzhou Dianzi University



無人之境

Mouyanzeng

作者姓名 Name of Designer(s)

陳仕宏

Shi-Hong Chen

指導老師 Instructor(s)

無

None

學校所在地 Location of School

臺灣

Taiwan

學校名稱 Name of School

嶺東科技大學

Ling Tung University

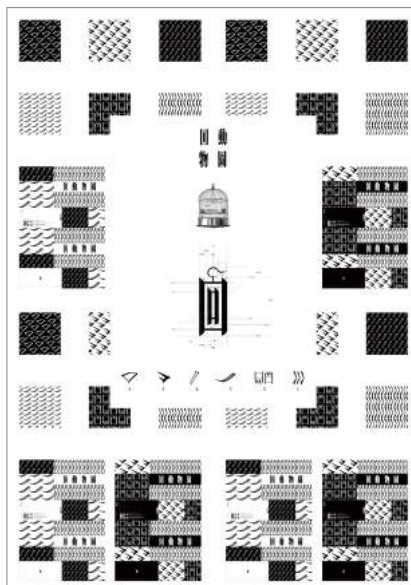
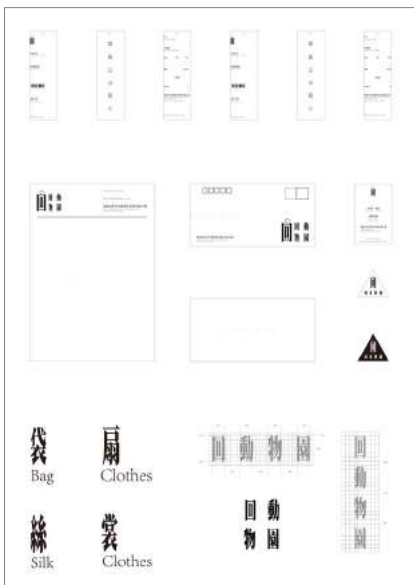

回動物園

Back to the Zoo

作者姓名 Name of Designer(s)

寧靈

Xi Ning

指導老師 Instructor(s)

趙炎龍

Yan-Long Zhao

學校所在地 Location of School

中國大陸

China

學校名稱 Name of School

華僑大學

Huaqiao University



## 人之五臟六腑 Human Organs

作者姓名 Name of Designer(s)

仲晨晨、張源

Chen-Chen Zhong, Yuan Zhang

指導老師 Instructor(s)

申洪瑞

Hong-Rui Shen

學校所在地 Location of School

中國大陸

China

學校名稱 Name of School

南京工業大學浦江學院

Nanjing Tech University Pujiang Institute



## 設計廈門

### Design Xiamen

作者姓名 Name of Designer(s)

李萌

Meng Li

指導老師 Instructor(s)

無

None

學校所在地 Location of School

中國大陸

China

學校名稱 Name of School

遼寧師範大學

Liaoning Normal University



## 魯迅圖書館 VI 設計

### Luxun Library

作者姓名 Name of Designer(s)

羅文聰

Wen-Cong Luo

指導老師 Instructor(s)

蔡仕偉

Shi-Wei Cai

學校所在地 Location of School

中國大陸

China

學校名稱 Name of School

汕頭大學長江藝術與設計學院

Cheung Kong School of Art & Design







## 花茶

### Scented Tea

作者姓名 Name of Designer(s)

王禕禕

Yi-Yi Wang

指導老師 Instructor(s)

無

None

學校所在地 Location of School

義大利

Italy

學校名稱 Name of School

卡拉拉美術學院

Accademia di Belle Arti di Carrara

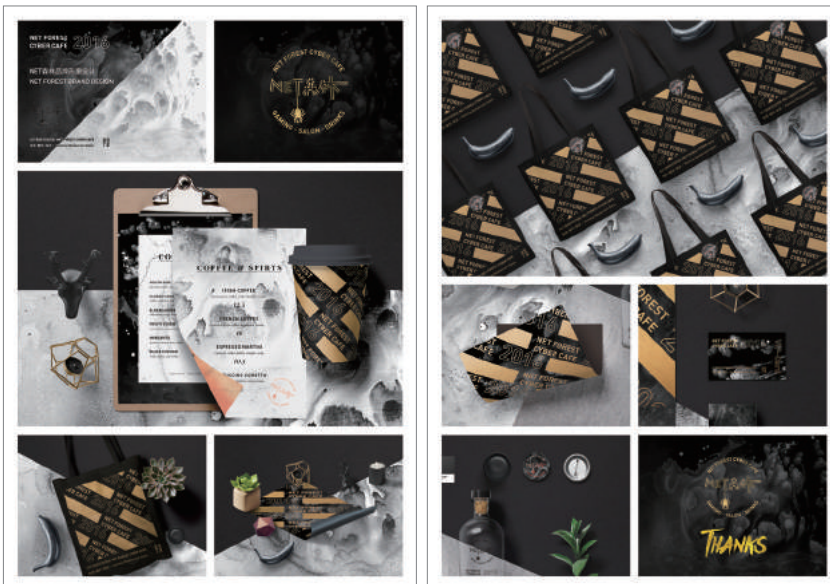

## NET 森林網咖品牌形象

### NET Forest Coffee Brand Design

作者姓名 Name of Designer(s)

趙猛

Meng Zhao

指導老師 Instructor(s)

李彥彬

Yan-Bin Lee

學校所在地 Location of School

中國大陸

China

學校名稱 Name of School

河北大學

Hebei University





2017

# Opportunity

數位動畫類得獎作品

Winners of Digital Animation Category



## 金獎作品評審講評 Jury Comments on Gold Prize

### 劉華智 Mann Lao

澳門 Macau

我身為一個動畫類的評審，個人認為動畫最重要的就是風格，也許每位評審喜歡的風格所見不同，但一般而言在評選時，我們都會先從風格去探究，因為任何一個設計或創作必須具備有一個好的風格，而相對來說作品的故事或是手法大致上都是可以模仿的，但是風格和藝術概念卻是無法如出一轍的效仿。這部動畫的風格十分具有“Opportunity”的味道，而且音樂和畫面顏色都搭配得宜且相當具有創作者獨特的藝術概念，因此是我選這部作品為金獎的主要原因。

As a juror of the Digital Animation category, I believe that the most important thing for an animation is its style. Perhaps every juror has his or her own preferred style, but during the selection process, we usually start by discussing the style. The reason is because any good design or creation requires a good style. Relatively speaking, the story or the techniques can be imitated more or less, but the style and the artistic concepts cannot be exactly imitated. The style of this animation has a very strong taste of "Opportunity," and the music and colors are both appropriate and quite reflective of the unique artistic concepts of the designers. These are the main reasons why I selected this work to be the gold prize winner.

### Zachary Haris Ong

馬來西亞 Malaysia

我個人對於金獎《霓虹》的看法是，整體製作品質而言是個很棒的作品，從顏色到圖像到敘述、音效與配樂，整體製作都非常得流暢，執行得很精細，被挑選為金獎可以說是實至名歸。

My opinion about the gold prize winning work, Neon, is that, in terms of the overall production quality, it is a wonderful piece of work. From the colors and imagery to the narration, sound effects and music, the overall production is very smooth, and the implementation is quite delicate. It undoubtedly deserves to be selected for the gold prize.

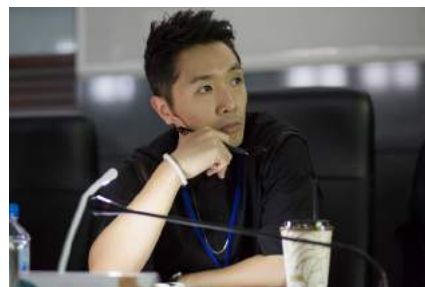



## 霓虹

### Neon

作者姓名 Name of Designer(s)

盤思妤、陳昭名、陳聖勛  
Sz-Yu Pan, Zhou-Ming Chen,  
Sheng-Hsun Chen

指導老師 Instructor(s)

石昌杰、陳建宏、王尉修  
C.Jay Shih, Chieh- Hung Chen,  
Wei-Xiu Wang

學校所在地 Location of School

臺灣

Taiwan

學校名稱 Name of School

國立臺灣藝術大學  
National Taiwan University of Arts



作品說明 Project Description

氛，這種氣體，無色、無味、無嗅，但放入玻璃管通電後卻會發出橘紅色的霓虹光。科學家發現時覺得非常新奇和炫目，於是取名為「Neon」也就是「新」的意思。我們以霓虹的概念來揭示愛情。在臺北都市夜晚，都市艷麗的霓虹光照耀著男孩與女孩，他們各自前往約定的地方，並在路途中回憶著過去他們因為相愛所散發出的橘紅色霓虹光。

Neon is a type of gas that is colorless, tasteless, and odorless. When it is put into a glass tube and electrically stimulated, it generates orange neon light. The scientist find it very intriguing and dazzling, and it is thus named neon which represents newness. We interpret love with the concept of neon. The neon lights are explained as the concept of love in this animation. At the night of Taipei city, neon lights shone gorgeously on the boy and the girl, while they were heading to the destination.



## The Fire Celebration at Kurama

作者姓名 Name of Designer(s)

Yosuke Tani

指導老師 Instructor(s)

Mitsuko Okamoto

學校所在地 Location of School

日本

Japan

學校名稱 Name of School

東京藝術大學

Tokyo University of the Arts



### 作品說明 Project Description

由岐神社位於京都的鞍馬，而每年神社都會舉辦一場獨一無二的火祭。這部影片結合了紀錄片元素與想像的情節，描繪出共同打造火祭的眾人、神祇與鬼魂。

Yuki-jinja Shrine is located in Kurama, Kyoto. Every year, a unique fire festival is held at the shrine. This film mixes documentary and fantasy to depict the people, deities, and spirits who create the festival together.







## Flipped Out

作者姓名 Name of Designer(s)  
Jihyeon Bae

指導老師 Instructor(s)  
Hsiang-Chin Moe

學校所在地 Location of School  
美國  
United States of America

學校名稱 Name of School  
紐約視覺藝術學院  
School of Visual Arts



### 作品說明 Project Description

「Flipped Out」是一部關於舊式翻蓋手機的 2D 動畫影片，這種翻蓋手機正被最新的智慧型手機款式取而代之。這部動畫的手繪風格突顯了影片欲傳達的訊息，那就是當面對無可避免的淘汰時，必須帶著優雅、智慧與自知之明。換句話說：必須要接受自己的限制，並且向前邁進！

"Flipped out" is a 2D animated film about an old flip phone who gets replaced by the latest smartphone model. The animation's hand-drawn style complements the film's message which is to face inevitable obsolescence with grace and wisdom as you gain self-knowledge. In other words: accept your limitations and move on!

## 蛋蛋的煩惱

## Go Nuts

作者姓名 Name of Designer(s)

楊凱雲、王培萍、花婉齊  
Kai-Yun Yang, Yu-Ping Wang,  
Wan-Ci Hua

指導老師 Instructor(s)

石昌杰、陳建宏、王尉修  
C.Jay Shih, Chieh-Huang Chen,  
We-Xiu Wang

學校所在地 Location of School

臺灣  
Taiwan

學校名稱 Name of School

國立臺灣藝術大學  
National Taiwan University of Arts



作品說明 Project Description

在歐美風行「世界 No Bra 日」與「解放乳頭」等運動時，亞洲女性還身處在社會框架下而無法感同身受，我們女人普遍從小就開始穿戴的胸罩，跟所有加諸在我們身上的審美標準一樣，是一種父權的束縛，束縛本身不可怕，沒有查覺到被束縛才是可怕的，GO NUTS（蛋蛋的煩惱）是一部用「男性穿著蛋蛋套」來諷刺父權主義下女性受到社會框架限制的一部短片。片中藉由把胸罩穿戴在男性身上，讓女性去反思胸罩的功能與其社會涵意，並喚醒女性的自由意識，也讓男性能更切身體會穿戴胸罩造成的壓迫感。

Go Nuts is a film about women freedom and liberty form society.

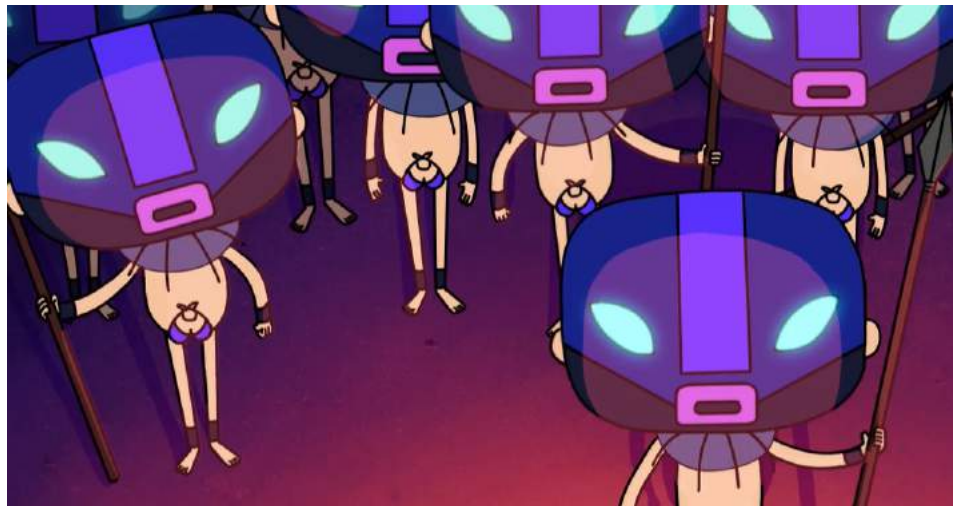
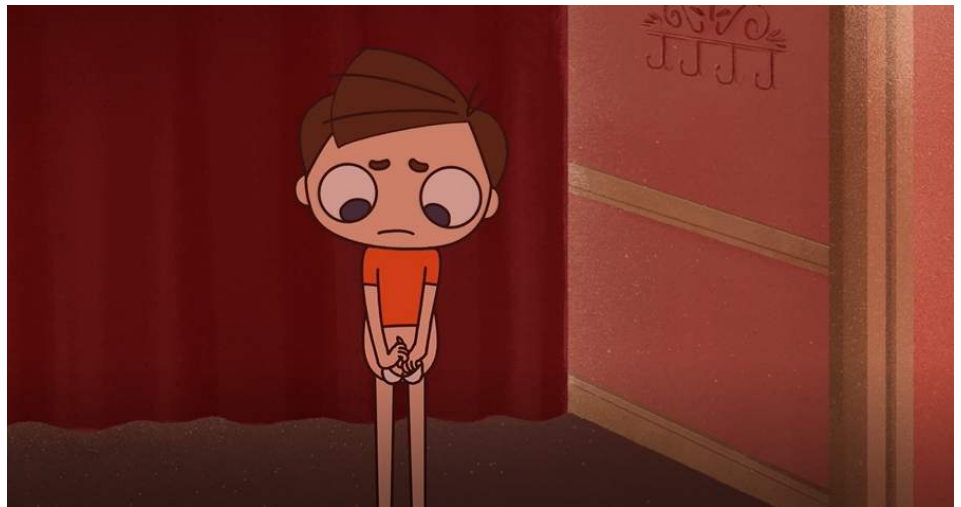



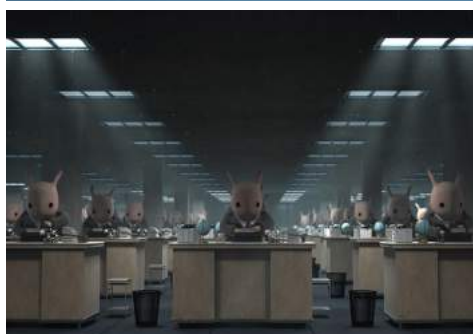
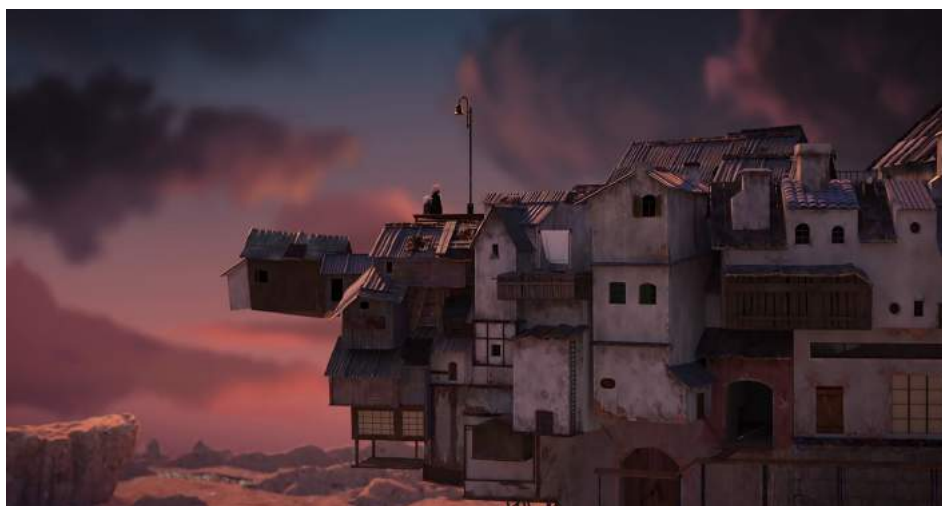

## Harry

作者姓名 Name of Designer(s)

周浩然

Harry Zhou

指導老師 Instructor(s)

柳喆俊

Ellon Leo

學校所在地 Location of School

中國大陸

China

學校名稱 Name of School

同濟大學

Tongji University



### 作品說明 Project Description

《Harry》是一部緬懷童年的動畫短片。一天一群飛魚飛過小鎮的天空，自此小男孩開始了漫長的等待，卻再也不見飛魚的回歸。小鎮的周圍開始建起了高樓，他也在循環的工作中漸漸的消耗了自己，而等待卻依舊延續。大雪淹城，風雪中他以一種特別的方式與他們再次相逢。

《Harry》 is the graduation project of mine . One day, a group of blue fish flying over the town, since then the boy began a lifetime waiting. Tall buildings grew around the town and he also gradually used up in the Circular work, However , those flying fish never come back. Finally , In the snow, he met them again in a special way.



## E-Delivery

作者姓名 Name of Designer(s)

Young Gul Cho

指導老師 Instructor(s)

Adam Meyers

學校所在地 Location of School

美國

United States of America

學校名稱 Name of School

紐約視覺藝術學院

School of Visual Arts



### 作品說明 Project Description

「E-delivery」是Young Gul Cho的3D動畫短片，內容是關於一座嬰兒工廠。這部作品批判著當今人類完全仰賴機器的文化氛圍。在未來，機器有沒有可能影響我們繁衍後代的自然生物本能呢？這部影片帶領著我們進入一座生產人類的工廠裡，讓我們得以一探究竟。觀眾可能會覺得新奇，可能會覺得恐怖，或者兩者皆是。

E-delivery is Young Gul Cho's 3D short animation about a baby factory. The project critiques today's cultural climate of human's total dependency on machines. Is it possible that machines will disrupt our natural biological imperative to reproduce? The film takes us into a factory that produces humans so we can see what that's like. Audiences may be amused, horrified, or both.

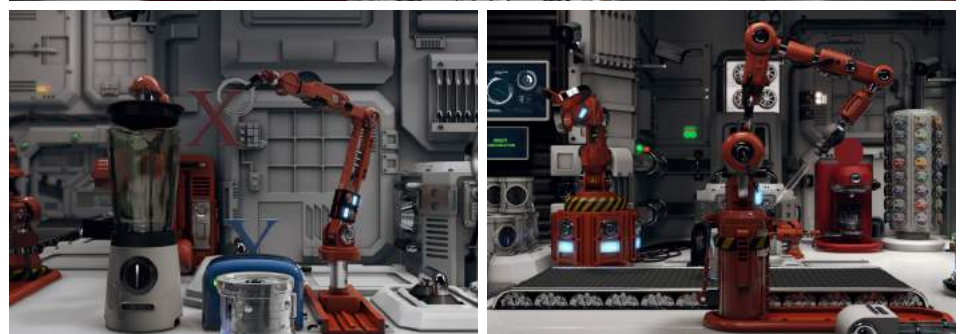
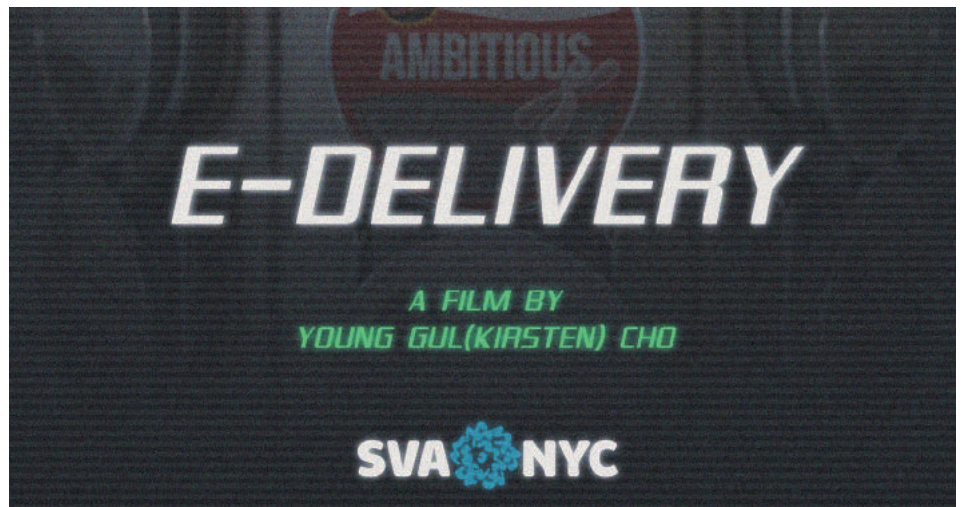

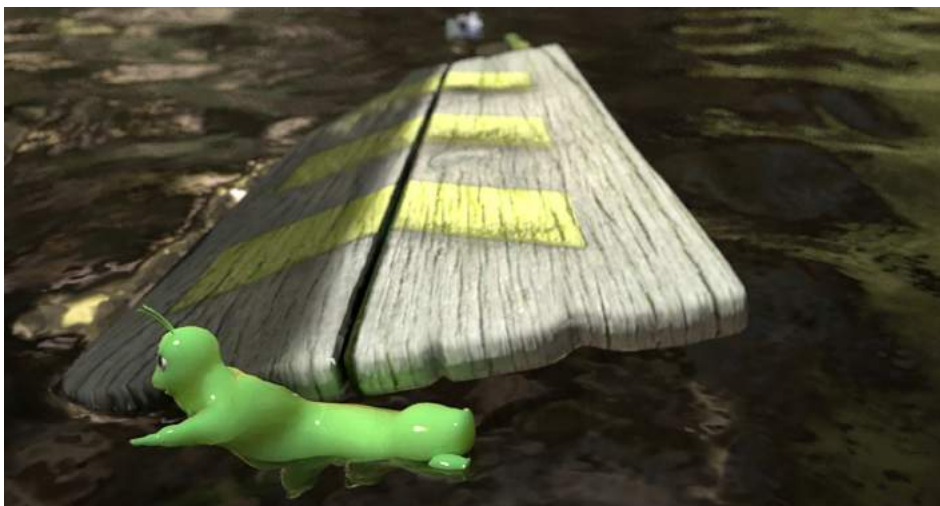

**盲蟲**  
**Blindly**

作者姓名 Name of Designer(s)

林書彥

Shu-Yen Lin

指導老師 Instructor(s)

鄧偉忻

Wei-Hsin Teng

學校所在地 Location of School

臺灣

Taiwan

學校名稱 Name of School

崑山科技大學

Kun Shan University



作品說明 Project Description

一隻肥肥的毛毛蟲，找尋著森林中最好吃的葉子。突然，一群毛毛蟲賽跑選手從一旁竄出，撞倒了主角！跑者們的終點，正是一片看起來最鮮嫩可口的葉子！在激烈的競爭中，主角到底能不能吃到那片最美味的嫩葉呢？

A fatness caterpillar is looking for a tasty leaf in jungle. A group of caterpillar runners show up immediately and make it fall down. The fatness caterpillar try to get itself up and eye on the front of runners. It found a tasty and refreshing leaf at the terminal point. It feel so excite and try to get on it. But it have to face the others runner and some trouble issues first before to get the leaf. Will the fatness caterpillar success to get its target? Let's us wait and see what gonna happen.



## 補月者

### Fill the moon

作者姓名 Name of Designer(s)

王靖婷、張秋月、陸韓英  
Jing-Ting Wang, Qiu-Yue Zhang,  
Han-Ying Lu

指導老師 Instructor(s)

郭磊  
Lei Guo

學校所在地 Location of School

中國大陸  
China

學校名稱 Name of School

中國美術學院  
China Academy of Art



#### 作品說明 Project Description

夜晚，缺了一角的月亮，懸掛在夜空中。穿紅色披風的男人，在寂靜的小鎮裡穿梭，來回於熟睡的人們床前，收取他們的美夢，去填補不完善的月亮。二維手繪的逐幀動畫，描繪一個浪漫的童話故事。希望它可以守護你美好的夢境。

A corner of the moon, suspended in the night sky. Men in red cloaks move through the silent towns, in front of the sleeping people, to fill their dreams and fill the imperfect moon. Frame by frame animation. Describe a romantic fairy tale. I hope it will protect your wonderful dreams.





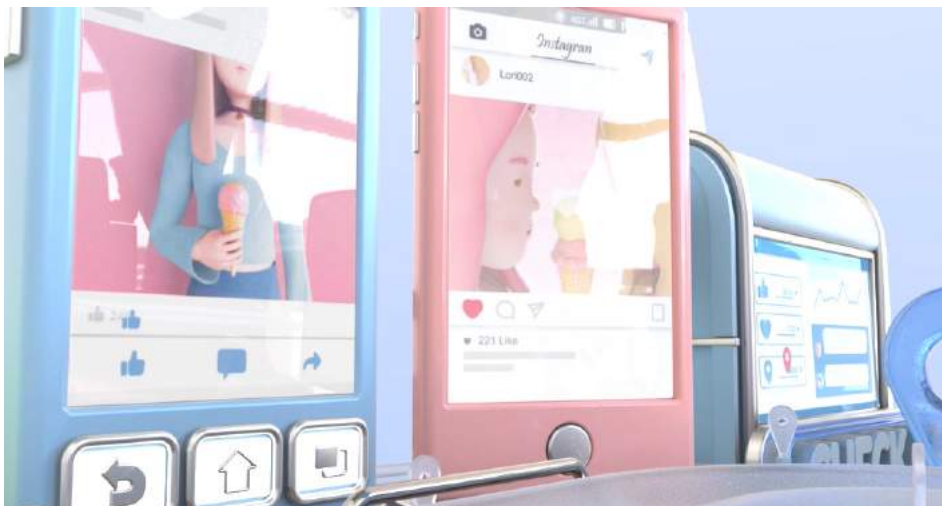
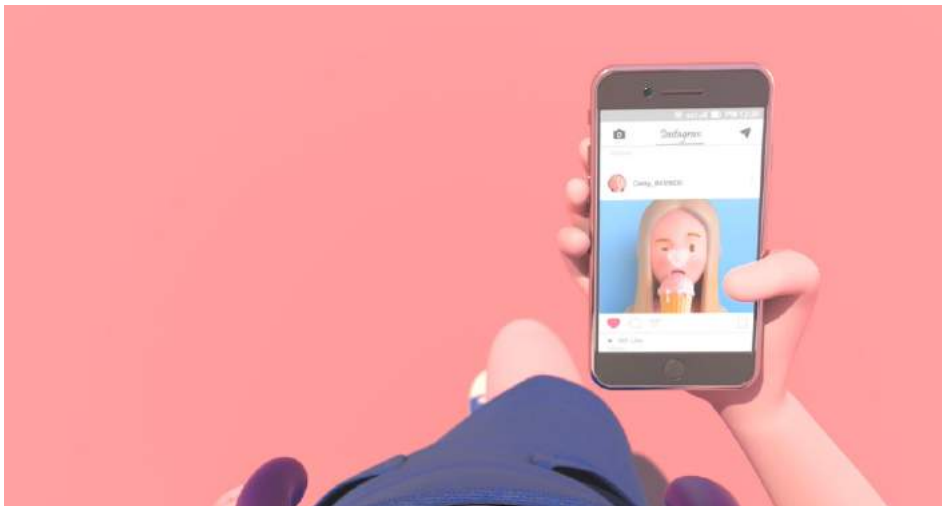
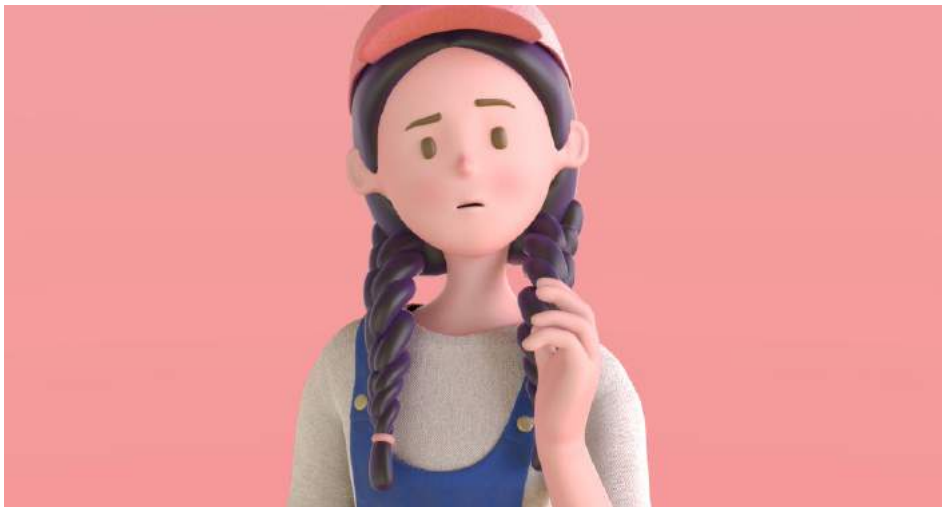

來個冰淇淋  
Want Some Ice Cream

作者姓名 Name of Designer(s)  
張晉璋、齊慕夷、羅健銘  
Jin-Wei Chang, Mu-Yi Chi,  
Chien-Ming Lo

指導老師 Instructor(s)  
翁鉅奇、林家華  
Chu-Chi Weng、Chia-Hua Lin

學校所在地 Location of School  
臺灣  
Taiwan

學校名稱 Name of School  
大同大學  
Tatung University



作品說明 Project Description

生活中的全部，幾乎是由選擇相繼拼湊連接而成。小至學生時期，在選擇題前陷入無盡的思索；大至人生的抉擇，徹夜難眠。我們都清楚，種種選擇的背後經歷的可都是一場大腦中理性與感性的拉扯風暴。很多的事情，沒有表面上看起來的輕鬆簡單。這就是 Want some ice cream 最初的發想，讓我們用趣味動畫的方式，帶出人類大腦思考時最抽象也最神秘的當下瞬間。

Our daily life is consist of decisions. From when we were student, facing multiple choice questions, to life's choices that keep us awake at night. And we all know that with every decision, our mind went through a journey between sense and sensibility, things aren't as easy as it seems. This is the original idea of Want some ice cream. Let us bring out the most abstract and mysterious moment of the human brain with fascinating animation.

## 家家酒

### PlayHouse

作者姓名 Name of Designer(s)

余聿

Yu Yu

指導老師 Instructor(s)

Michael Patterson, Candace Reckinger

學校所在地 Location of School

美國

United States of America

學校名稱 Name of School

南加州大學

University of Southern California



#### 作品說明 Project Description

全家人等待著父親回家吃晚餐。但當父親好不容易到家了，他只專注於手中的螢幕，看也不看他的家人一眼，直到他看到了另一個家庭的全家福……如果孩子有選擇的機會，他會選擇遵從父親的指示，繼續待在這個家家酒般的家庭中嗎？

The whole family is waiting for the father to come home for dinner. Yet when the father finally gets home, he focuses on nothing else but the screen he holds, until he sees another family's picture.....If we give the kids an opportunity to choose by themselves, will they keep staying in this playhouse like family?





沉默的牆

Wall

作者姓名 Name of Designer(s)

張素華、鄭欣佩

Su-Hwa Chang, Sin-Pei Jheng

指導老師 Instructor(s)

陳世昌

Shi-Chang Chan

學校所在地 Location of School

臺灣

Taiwan

學校名稱 Name of School

國立雲林科技大學

National Yunlin University of Science and Technology



作品說明 Project Description

從一面牆感受時間的推進，陳述事件的發生與時代環境的改變，以現實的牆暗喻人民，即使經歷壓迫，牆一度被摧殘，但人民最後總能團結度過難關，脆弱卻又堅強，正是人類的特質。意識到這一點正是我們轉變的機會，鼓起勇氣，攜手走向更美好的未來吧！

From a wall to feel time which is non stop, to tell a story how it is happen and the change of time and environment. Using a solid wall to imply people, even face domination, wall once had been destroyed. However, people always can stand up again by uniting together to pass through all the difficulties finally. People look fragile but strong inside, just is a unique character of human race. Unity is the opportunity to change.





以上

### Above the Cloud

作者姓名 Name of Designer(s)

黃靜、賈麗琦

Eva Huang, Jane Jia

指導老師 Instructor(s)

楊博

Bo Yang

學校所在地 Location of School

中國大陸

China

學校名稱 Name of School

西安美術學院

Xi'an Academy of Fine Arts



#### 作品說明 Project Description

運用全新的數字繪畫作為技術支撐，探索最新的視覺表現形式，重新組織鏡頭語言與影片剪輯結構，來詮釋“女權主義”這一社會公共主題，通過作品為女性主義發出聲音，來呼籲更多的關注與思考。

Using the new digital painting as a technical support, to explore the latest forms of visual expression, re-organization of the lens language and video clip structure, to interpret the feminist social public theme, through the work for feminist voice, to call more concern and thinking.

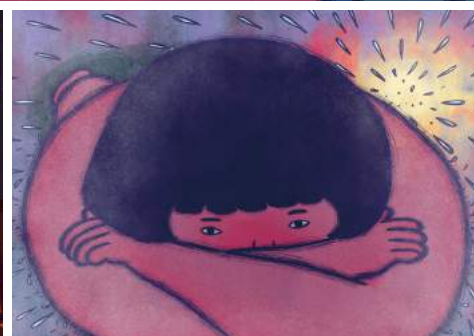
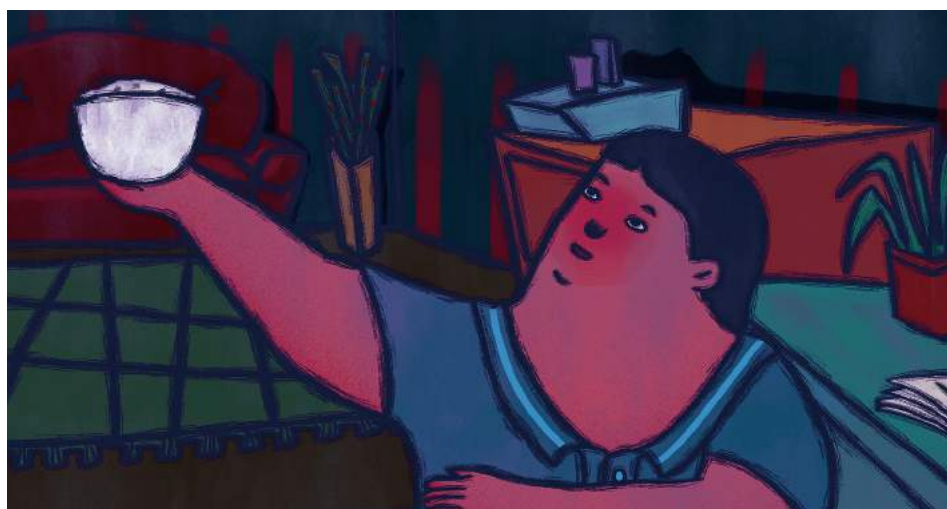
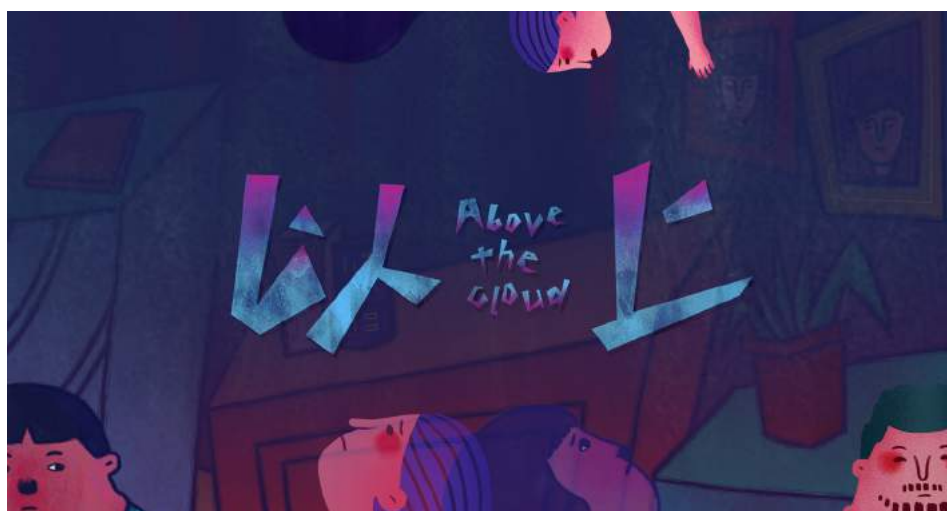



布谷布谷  
**Cuckoo Cuckoo**

---

作者姓名 Name of Designer(s)

張浩、江曉飛

Hao Zhang, Xiao-Fei Jiang

指導老師 Instructor(s)

李冉

Ran Li

學校所在地 Location of School

中國大陸

China

學校名稱 Name of School

天津科技大學

Tianjin University of Science & Technology



**Empyrean Lost**

---

作者姓名 Name of Designer(s)

Ruiling Deng

指導老師 Instructor(s)

無

None

學校所在地 Location of School

美國

United States of America

學校名稱 Name of School

紐約視覺藝術學院

School of Visual Arts

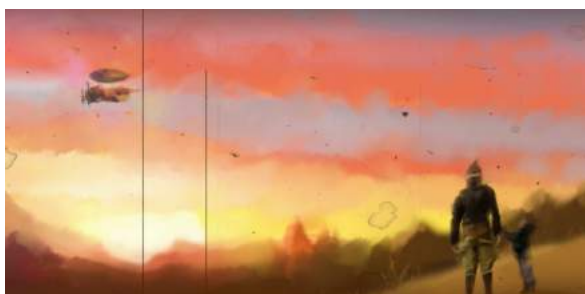

《零》

《Ling》

---

作者姓名 Name of Designer(s)

許洋

Yang Xu

指導老師 Instructor(s)

戴凌瑞

Ling-Rui Dai

學校所在地 Location of School

中國大陸

China

學校名稱 Name of School

天津工業大學

Tianjin Polytechnic University



## 不想長大

### Don't Wanna Grow Up

作者姓名 Name of Designer(s)

蘇昱汶、郭雅云、陳穎潔、呂昕  
Yu-Wen Su, Ya-Yun Kuo,  
Ying-Chieh Chen, Hsin Lu

指導老師 Instructor(s)

石昌杰、陳建宏、張維忠  
C. Jay Shin, Chieh-Hung Chen,  
Wei-Chung Chang

學校所在地 Location of School

臺灣  
Taiwan

學校名稱 Name of School

國立臺灣藝術大學  
National Taiwan University of Arts



## Entia-Portadores de vida

作者姓名 Name of Designer(s)

Virgilio Abraham Cortez Recinos

指導老師 Instructor(s)

無  
None

學校所在地 Location of School

薩爾瓦多  
El Salvador

學校名稱 Name of School

薩爾瓦多理工大學  
Universidad Tecnologica



## #WHO

作者姓名 Name of Designer(s)

連靖函、雷千雪  
Jing-Han Lian, Chin-Suet Louie

指導老師 Instructor(s)

石昌杰、陳建宏、張維忠  
C. Jay Shih, Chieh-Hung Chen,  
Wei-Chung Chang

學校所在地 Location of School

臺灣  
Taiwan

學校名稱 Name of School

國立臺灣藝術大學  
National Taiwan University of Arts

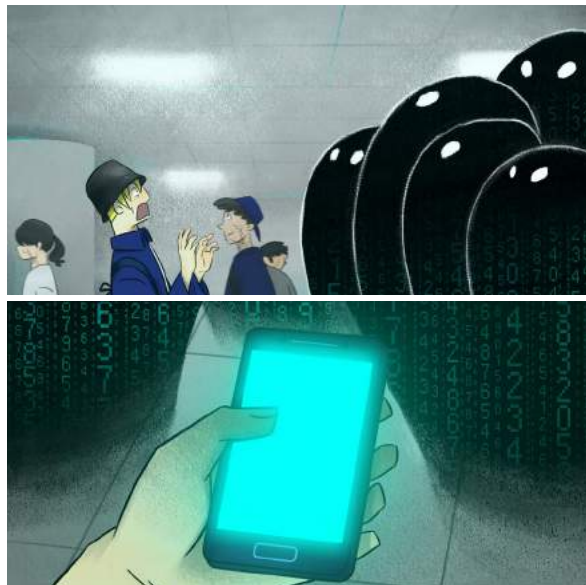





## 孤肢

### GuZhi

作者姓名 Name of Designer(s)

魏大荃、吳牧人、賴宛琳、林孝親、林思妤

Tai-Chuan Wei, Mu-Jen Wu, Wan-Lin Lai, Hsiao-Chin Lin, Szu-Yu Lin

指導老師 Instructor(s)

陳世昌

Shih-Chang Chen

學校所在地 Location of School

臺灣

Taiwan

學校名稱 Name of School

國立雲林科技大學

National Yunlin University of Science and Technology

## Neko

作者姓名 Name of Designer(s)

曾品喬、蔡孟書、柳育琪、許子甫、王璋凡、林顯庭

Pin-Ciao Zeng, Meng-Shu Tsai, Yu-Chi Liu, Tzu-Fu Hsu, Wei-Fan Wang, Hao-Ting Lin

指導老師 Instructor(s)

黃昭智、劉千凡

Chao-Chih Huang, Chian-Fan Liou

學校所在地 Location of School

臺灣

Taiwan

學校名稱 Name of School

南臺科技大學

Southern Taiwan University of Science and Technology

## 廿三味

### 23 Herbs

作者姓名 Name of Designer(s)

蔡理鐸

Li-Duo Cai

指導老師 Instructor(s)

柴文娟、劉琛、葉梓琪、李雄飛

Wen-Juan Chai, Chen Liu, Zi-Qi Ye, Xiong-Fei Li

學校所在地 Location of School

中國大陸

China

學校名稱 Name of School

廣州美術學院

Guangzhou Academy of Fine Arts

## 沙坡之尾

### Tail of Shapo

作者姓名 Name of Designer(s)

高凱、胡瑪麗、吳長景  
Kai Gao, Ma-Li Hu, Chang-Jing Wu

指導老師 Instructor(s)

黃曉瑜、黃曉梅  
Xiao-Yu Huang, Xiao-Mei Huang

學校所在地 Location of School

中國大陸  
China

學校名稱 Name of School

福州大學  
Fuzhou University

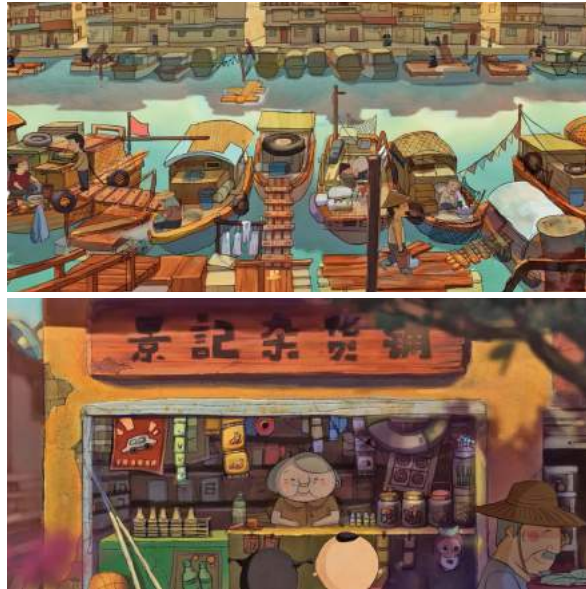

## 我的家人

### My Family

作者姓名 Name of Designer(s)

唐恒一、余晨霜、應運、宋馨瑤、  
馬鳴旋

Heng-Yi Tang, Chen-Shuang Yu, Yun Ying,  
Xin-Yao Song, Ming-Ni Mang

指導老師 Instructor(s)

韓永毅、張軼、王蕾  
Yong-Yi Han, Yi Zhang, Lei Wang

學校所在地 Location of School

中國大陸  
China

學校名稱 Name of School

天津美術學院  
Tianjin Academy of Fine Arts



## 曜

### Wish

作者姓名 Name of Designer(s)

馬筠婷、劉庭安、徐廷源、耿佳瑀、  
郭盈君、江祐萱

Yun-Ting Ma, Ting-An Liu, Ting-Yuan Hsu,  
Jia-Yu Geng, Ying-Jyun Guo, You-Xuan Jiang

指導老師 Instructor(s)

黃昭智、劉千凡  
Chao-Chih Huang, Chian-Fan Liou

學校所在地 Location of School

臺灣  
Taiwan

學校名稱 Name of School

南臺科技大學  
Southern Taiwan University of Science and  
Technology

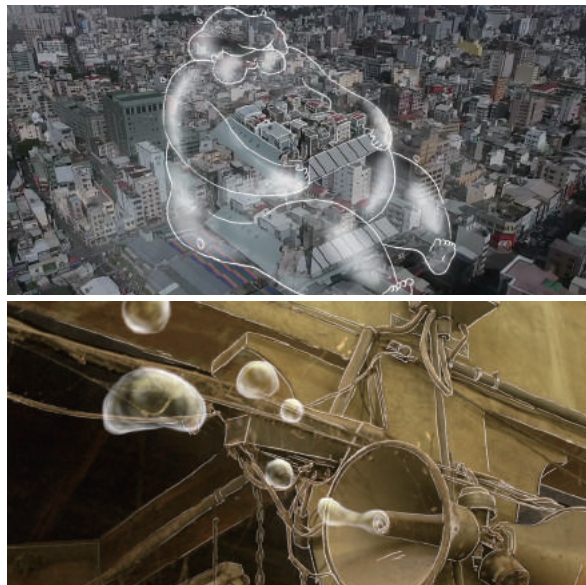





圈

### Circle

作者姓名 Name of Designer(s)

王廣苗

Guang-Miao Wang

指導老師 Instructor(s)

姜曉東

Xiao-Dong Jiang

學校所在地 Location of School

中國大陸

China

學校名稱 Name of School

天津美術學院

Tianjin Academy of Fine Arts



### Kunfu Crazy

作者姓名 Name of Designer(s)

Nitiphum

指導老師 Instructor(s)

Pratana Jaroensukpanich

學校所在地 Location of School

泰國

Thailand

學校名稱 Name of School

斯巴頓大學

Sripatum University



### 枝仔冰

### Popsicle

作者姓名 Name of Designer(s)

楊子新

Tzu-Hsin Yang

指導老師 Instructor(s)

Fran Krause

學校所在地 Location of School

美國

United States of America

學校名稱 Name of School

加州藝術學院

California Institute of the Arts



一個憂傷者的求救  
A Sad Person Call for Help

作者姓名 Name of Designer(s)

謝菲  
Fei Xie

指導老師 Instructor(s)

黃曉瑜  
Xiao-Yu Huang

學校所在地 Location of School

中國大陸  
China

學校名稱 Name of School

福州大學  
Fuzhou University



我那會做飯的外公啊  
My Grandfather Who Can Cook

作者姓名 Name of Designer(s)

尚芳、趙醒、毛迪、劉小敏、  
曲祉潔  
Fang Shang, Xing Zhao, Di Mao,  
Xiao-Min Liu, Zhi-Jie Qu

指導老師 Instructor(s)

韓永毅、王麗莎、張軼  
Yong-Yi Han, Li-Sha Wang, Yi Zhang

學校所在地 Location of School

中國大陸  
China

學校名稱 Name of School

天津美術學院  
Tianjin Academy of Fine Arts



風吹  
Kite

作者姓名 Name of Designer(s)

林昕  
Hsin Lin

指導老師 Instructor(s)

林大偉  
Dai-Wei Lin

學校所在地 Location of School

臺灣  
Taiwan

學校名稱 Name of School

國立臺北藝術大學  
Taipei National University of the Arts





### 雲霄之上

#### The End of the Sky

作者姓名 Name of Designer(s)

陳永康、晉睿、王建宇

Yong-Kang Chen, Rui Jin, Jian-Yu Wang

指導老師 Instructor(s)

王青、王幼怡

Huan-Qing Wang, You-Yi Wang

學校所在地 Location of School

中國大陸

China

學校名稱 Name of School

北京服裝學院

Beijing Institute Of Fashion Technology



### 《塵》

#### Dust

作者姓名 Name of Designer(s)

蒲權中、莊寶員、王哲勳、劉洋姿、王佳妮

Quan-Zhong Pu, Bao-Yuan Zhuang,  
Zhe-Xun Wang, Yan-Gzi Lou,  
Jia-Ni Wang

指導老師 Instructor(s)

鄧強、毛波

Qiang Deng, Bo Mao

學校所在地 Location of School

中國大陸

China

學校名稱 Name of School

西安美術學院

Xi'an Academy of Fine Arts

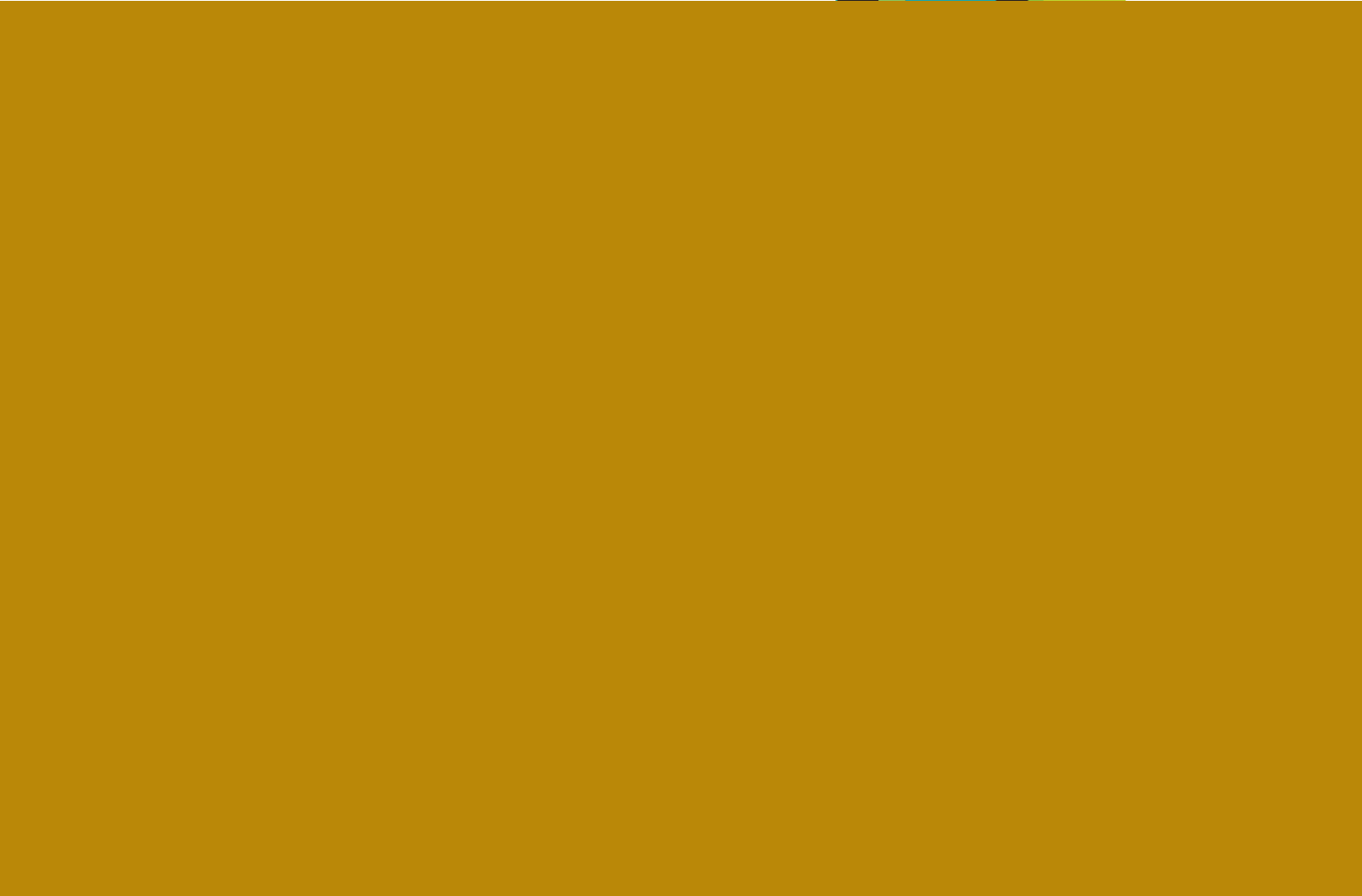





2017

# Opportunity

---

贊助廠商介紹

About Sponsors





財團法人看見台灣基金會  
iSee Taiwan Foundation

## 財團法人看見台灣基金會

### iSee Taiwan Foundation

---

財團法人看見台灣基金會於 2003 年由溫世仁先生籌備成立，2008 年溫泰鈞先生接掌董事長後，正式確立本會願景為「成為世界認識台灣的重要窗口」，以「文化」、「觀光」、「創新」作為本會三大核心主軸，也訂定使命為「將台灣特色成功行銷到國際」和「讓全球成為台灣服務市場」。秉持著愛惜台灣，讓世界看見台灣美好的精神，持續發掘、整合、行銷在各個角落發光發熱的在地生活文化及豐厚人情，藉此吸引更多的外國人來台灣，開拓台灣的服務市場。

Mr. Sayling Wen founded the iSee Taiwan Foundation in 2003. After becoming Chairman in 2008, Ted Wen formalized the vision of the foundation as "becoming an essential portal for the world to see Taiwan" in the three core realms of culture, tourism, and innovation. The dual missions of the iSee Taiwan Foundation are to successfully market Taiwan's unique character and heritage globally and to make the world the target of Taiwan's service market. continued to promote the spirit of loving Taiwan; to focus the world's attention on Taiwan's beautiful spirit; and to illuminate, integrate and promote the culture and friendly nature of places throughout Taiwan with the ultimate goals of encouraging more inbound tourism and boosting demand and opportunities for the domestic service industry.



財團法人溫世仁  
文教基金會  
Sayling Wen Cultural & Educational Foundation

## 財團法人溫世仁文教基金會

### Sayling Wen Cultural & Educational Foundation

---

財團法人溫世仁文教基金會，秉持「教育」、「創新」、「關懷」三大核心主軸，一步一腳印地在台灣這塊土地落實「育就人文關懷、創新思維的溫馨社會」願景，持續朝著深耕國中小學生中華文化教育、強化高中職及大專生職能培育、促進社會人士跨領域的廣度知識學習、推廣服務科學協助提升國家競爭力等四大重點發展方向邁進；從教育出發、用創新的方式、本著關懷的心，為培育優質人才及提升國家競爭力、扮演台灣轉型升級的關鍵角色。

Mr. Ted Wen, the incumbent Chairman of the Foundation, has declared three core principles for the Foundation: Education, Innovation, and Care. Pivoted around these core values is his vision to "Nurture a warmhearted society of humanist devotion and innovative thinking." The Foundation's continuing efforts in promoting educational programs. Going forward, the four pillars of the Foundation will be embedding the Chinese culture education in primary and secondary schools, enhancing career skills and teamwork mindset for vocational and college students, promoting lifelong learning in community and advocating service innovation to boost national competitiveness. While Taiwan is on its way toward a sophisticated "Service Economy", the Foundation will also continue to devote every effort to promote the four pillars with the aim to breed new service talents, enhance Taiwan's national competitiveness, and play a key enabling role to Taiwan's transformation.







2017

# Opportunity

廠商指定類得獎作品

Winners of Brand Specified Category



看見台灣基金會  
iSee Taiwan Foundation

看見台灣基金會創新設計獎

iSee Taiwan Foundation Innovative Design Awards



### 關於徵件

#### 設計項目

財團法人看見台灣基金會 — 「新食器時代—臺灣茶具設計」

#### 目標對象

全球高中職及大專院校設計相關科系學生

#### 主要目標

1. 能運用在招待貴賓宴席上的茶具
2. 能展現台灣特色

#### 設計規範與注意事項

1. 以看見台灣基金會之願景為出發點，進行創意發想
2. 設計必須能與台灣或看見台灣基金會印象有直接連結
3. 所有設計項目皆需放上看見台灣基金會 logo
4. 期望設計調性：創新且具藝術與時尚感
5. 針對台灣形象，強調該項茶具獨特的功能性
6. 設計說明海報至多 4 張
7. 設計如使用特殊製作方式，可標註於創意說明文字中

### 關於廠商

#### 單位名稱

財團法人看見台灣基金會

#### 單位介紹

「財團法人看見台灣基金會」於 2003 年由溫世仁先生籌備成立，2008 年溫泰鈞先生接掌董事長後，正式確立願景為「成為世界認識台灣的重要窗口」，以「文化」、「觀光」、「創新」作為基金會三大核心主軸，也訂定使命為「將台灣特色成功行銷國際」、「讓全球成為台灣服務市場」，挖掘、整合、包裝、宣傳在各個角落發光發熱的在地生活文化及豐厚人情，藉此吸引更多的外國人來台灣，開拓台灣的服務市場。

#### 單位使命

將台灣特色成功行銷國際  
讓全球成為台灣服務市場

#### 參考網址

[www.iseetaiwan.org](http://www.iseetaiwan.org)



## About Entries

### Design Element

iSee Taiwan Foundation - Taiwan Teaware Design

### Target Audience

Worldwide students who are in design related fields

### Main Objectives

1. The teaware can be applicably used for better serving in formal occasions.
2. The teaware can perfectly express the uniqueness of Taiwan.

### Design Specifications and Notes

1. To generate creative ideas based on the vision of the iSee Taiwan Foundation.
2. The design must closely embody the image of Taiwan or the iSee Taiwan Foundation.
3. The logo of the iSee Taiwan Foundation must appear in all design elements.
4. Suggestions for design: inventive, artistic and modern.
5. The teaware design should emphasize iconic Taiwanese teaware and its unique function.
6. The posters of description of design can be presented maximum of 4.
7. If a special kind of printing or production method is used in the poster design, it can be indicated in the creative description.

## About the Foundation

### Name

iSee Taiwan Foundation

### Introduction

The foundation was established by Sayling Wen in 2003. Ted Wen became the Chairman in 2008, and set the Foundation's vision as "becoming an essential portal for the world to see Taiwan" in the three core realms of culture, tourism, and innovation. The dual missions of iSee Taiwan Foundation are to successfully market Taiwan's unique character and heritage globally and to make the world as Taiwan's service market. The foundation focuses on exploring, integrating and promoting the culture and friendly nature of people and places throughout Taiwan, with the goal of creating more opportunities for Taiwan's service industry.

### Mission

To successfully market Taiwan's unique character and heritage globally and to make the world the target of Taiwan's service market.

## 金獎作品評審講評 Jury Comments on Gold Prize

### 鄭道成 Do Sung Chung

韓國 Korea

不管是臺灣或是整個亞洲，其實對於茶文化的關係呈現逐漸減少的趨勢。而此作品在於使用新的方法向年輕世代傳達出新的可能性，利用創新的設計概念，表現出茶文化的傳統特色，是它得到金獎的主要原因。此件作品連結了飲食文化之間的關聯以及展現臺灣茶具主題的切合性，而品茶文化與飲食文化的結合，完整的呈現展現臺灣文化特色，因此我給予這件作品相當高的評價。

Whether it is in Taiwan or in the entire Asia, the attention towards tea culture has been on a gradual decline. This work adopts new approaches to convey new possibilities to the younger generation. It uses new design concepts to present the traditional characteristics of tea culture, which is the main reason why it won the gold prize. This entry combines food and beverage cultures and very much corresponds to the theme of "Taiwan Teaware." The integration of tea culture and food culture perfectly showcases the features of Taiwanese culture, so I highly acclaim this piece of work.

### 青木史郎 Shiro Aoki

日本 Japan

在日本文化中，喝茶的時候同時會搭配一種名為「落雁」的點心，這件作品它的優點是將配茶的點心也加入這個品茶的過程當中，應用在家庭品茶的時候，讓大人小孩能一起同樂，享受這個溫馨的天倫時光。另外一點非常值得給予高評價的，是在以往品茶的过程當中，常有主人與客人的關係，此件作品加入了一個「together」的觀念，讓大家可以一同享樂，因此我個人認為這是一個非常好的設計概念。

In Japanese culture, people enjoy a kind of desert called "Rakugan" while drinking tea. The strength of this entry is that it brings the desert that goes with tea into this process of tea tasting, as if we are in a family occasion, where parents and children drink tea together and enjoy the happiness of quality family time. Another point worth high acclaim is that, in the past, there was often a host-guest relationship in tea drinking occasions, but this work brings in the concept of being "together" so that everyone can enjoy and have fun. Therefore, I believe that this is a very good design concept.





製餅食茶

TeaLab

作者姓名 Name of Designer(s)

李貞儀

Chen-Yi Lee

指導老師 Instructor(s)

王俊隆

Rock Wang

學校所在地 Location of School

臺灣

Taiwan

學校名稱 Name of School

實踐大學

Shih Chien University



作品說明 Project Description

過去，臺灣人都有喝茶配糕餅的習慣。喝茶時，茶席邊會放上謝籃，裡面盛裝精緻茶點供客人享用。然而，茶從古到今一直是門博大精深的學問，糕餅卻常常淪為配角，在今日，除了過年過節、送禮之外，時常被人們遺忘。隨著咖啡、英式下午茶愈發興盛，茶餅文化逐漸沒落，製餅食茶希望喚醒現代人對臺灣茶點文化的記憶，整合茶與糕點，設計出一套臺式下午茶，它不像手搖店那樣倉促，也不像茶藝如此莊嚴拘謹難以親近，整合了製作糕餅的流程並將糕餅器具整合進茶具裡，整套茶具本身即能用來製作糕餅。希望像擺茶一樣，讓人們能體驗製作過程的樂趣，創造一套喝茶配餅話家常的下午茶點組。

Taiwanese tea and pastry complement each other bringing out the fragrance and sweetness. Coffee and British afternoon tea are getting popular nowadays, but Taiwanese should have our own style! "TeaLab" hopes to remind people of the culture of tea with pastry. Creating Taiwanese own afternoon tea set by integrating tea and pastry, it allows people to make pastry easily and enjoy tea time with friends together!



Motivation /

Drinking Taiwanese tea with pastry is known to the natives. People used to put snacks in gift baskets, especially when having tea and whenever guests visiting them. Tea has been regarded as an art and knowledge, but pastries usually become complements. They are often ignored except for being gifts or on the festival. If there were our own afternoon tea, which is not that random as handmade drinks and not that serious as tea arts.

過去，台灣人都習慣喝茶配糕餅的習慣。喝茶時，茶席邊會放上謝籃，裡面盛裝精緻茶點供客人享用。然而，茶從古到今一直是門博大精深的學問，糕餅卻常常淪為配角。在今日，除了過年過節、送禮之外，時常被人們遺忘。隨著咖啡、英式下午茶愈發興盛，茶餅文化逐漸沒落，製餅食茶希望喚醒現代人對臺灣茶點文化的記憶，整合茶與糕點，設計出一套臺式下午茶，它不像手搖店那樣倉促，也不像茶藝如此莊嚴拘謹難以親近。



Concept /

By interpreting the process of making pastry and integrating the pastry tools into tea set, the whole tea set can be used for making pastry. Wish people could enjoy the process of making pastry, such as making Hakka ground tea. Try to make the afternoon tea set pleased and easy to approach.

藉由製作糕餅的流程並將糕餅器具整合進茶具裡，整套茶具本身即能用來製作糕餅。希望像擺茶一樣，讓人們能體驗製作過程的樂趣，創造一套喝茶配餅話家常的下午茶點組。

Idea /

Combining tea set with all the tools of making pastry, stirring bowl, mold, teaspoon, and etc... are all included in the set.

茶具即是茶具，攪拌碗、糕模、茶湯匙等，應俱全且能與製作糕餅的用具結合。

Design evaluation /

Mold / How to combine pastry mold into tea set?



Make the cup bottom as mold and design it as tea bowl, but it's difficult to get the pastry out of the mold and the using process is hard to be understood.



Redesign it and take the mold apart changing it into top and bottom part in order to avoid the pastry from being stuck in the mold.

Assembling and storing / How to make it easy to accommodate but could also gracefully unfold on the table?



Trying lots of ways to assemble, for example, A is piled with small low tables and would be a big table when they are pieced together. It's easier to pick pastry from it.



The stirring bowl is designed to be round in order to combine it into the basket, but there's no enough space for placing spoon, tea pick, and seal... etc.





**80 at-tea 收納式多功能茶具組**  
**80 at-tea Admission**  
**Multifunction Tea Set**

作者姓名 Name of Designer(s)

張玉樺、呂淑惠

Yu-Hua Jhang, Shu-Hui Lu

指導老師 Instructor(s)

高繼徽

Ghi-Hwei Kao

學校所在地 Location of School

臺灣

Taiwan

學校名稱 Name of School

亞東技術學院

Oriental Institute of Technology



作品說明 Project Description

我們使用茶湯溫和圓潤形象以圓為元素將茶具組包裝出簡單現代感的新形象，並加入收納功能以不浪費空間與多用途為目標作設計，另外也有做置物空間可以放置計時器、溫度計或茶點。

We use the tea gentle smooth taste to take the circle as the element in the tea packaging a simple modern new image, and to take to not waste space and multi-purpose to target a design, it is also doing compartments can be placed timer, thermometer or the snack.





山·茶事  
Mountain · Tea Affairs

作者姓名 Name of Designer(s)

田文成、薛邁  
Wen-Cheng Tian, Mai Xue

指導老師 Instructor(s)

張春蓉、吳傑、劉丹丹  
Chun-Rong Zhang, Jie Wu, Dan-Dan Liu

學校所在地 Location of School

中國大陸  
China

學校名稱 Name of School

安陽工學院  
Anyang Institute of Technology

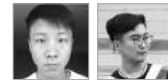

山·茶事 臺灣茶具系列設計

山·茶事 - 茶杯設計 Mountain · Tea Affairs - Cup design  
山·茶事 - 公道杯設計 Mountain · Tea Affairs - Justice cup design  
山·茶事 - 茶壺設計 Mountain · Tea Affairs - Teapot design  
山·茶事 - 茶壺設計 Mountain · Tea Affairs - Teapot design

**設計簡介**  
臺灣臺半以上的地形為山脈構成，多數著名旅遊景點均與山有關。整套設計以臺灣各大山脈為元素進行設計，包括：茶壺、茶杯、茶葉罐、公道杯、茶漏、茶托等壹系列設計，融入了臺灣各山脈的日出、雲海等景觀，在品茶的時候猶如欣賞到臺灣各山脈的奇異景觀。

**Introduction**  
More than half of Taiwan's terrain is mountain ranges, and most of the scenic spot are associated with mountains. Set design: teapot, teacup, Reasonable cup, tea strainer, saucer, and a series of designs based on the mountains of Taiwan, the sunrise, clouds and other landscape. While tasting tea, it is like appreciating the strange sights of the mountain ranges in Taiwan.

作品說明 Project Description

陸賀芬說過：「執著於自己的作品，在鍋裏也能找到上帝」。這麼多年來，陶所具有的自然感、土地感，深入人心。帶著對大自然的敬畏之心，讀懂她的質地、氣味、紋理，並結合自己對生活的感悟，然後再設計再創造，堅持把藝術生活化，把生活藝術化。臺灣一半以上的地形為山脈構成，多數著名旅遊景點均與山有關。整套設計以臺灣各大山脈為元素進行設計，包括：茶壺、茶杯茶葉罐、公道杯、茶漏、置物架等壹系列設計，融入了臺灣各山脈的日出、雲海等景觀，在品茶的時候猶如欣賞到臺灣各山脈的奇異景觀。

More than half of Taiwan's terrain is mountain ranges, and most of the scenic spot are associated with mountains. Set design: teapot, teacup, Reasonable cup, tea strainer, saucer, and a series of designs based on the mountains of Taiwan, the sunrise, clouds and other landscape. While tasting tea, it is like appreciating the strange sights of the mountain ranges in Taiwan.

山·茶事 臺灣茶具系列設計

山·茶事 - 茶壺設計 Mountain · Tea Affairs - Teapot design  
山·茶事 - 公道杯設計 Mountain · Tea Affairs - Justice cup design  
山·茶事 - 茶杯設計 Mountain · Tea Affairs - Cup design

原源不絕

Uninterrupted Flow

作者姓名 Name of Designer(s)

蕭翎軒

Ling-Xuan Xiao

指導老師 Instructor(s)

游明龍

Ming-Lung Yu

學校所在地 Location of School

臺灣

Taiwan

學校名稱 Name of School

亞洲大學

Asia University



原源不絕

喝茶文化的傳承，醞釀於杯盤中

台灣許多經典的茶種，來自於台灣的丘陵地，同時也是原住民族的居住地。原住民族喝茶，源自於對大自然的恩惠，傳承祖先對土地的尊敬。

作品說明 Project Description

喝茶文化的傳承，醞釀於杯盤中。臺灣許多經典的茶種，來自於臺灣的丘陵地。原住民族喝茶，源自於對大自然的恩惠，傳承祖先對土地的尊敬。

The tea culture tradition inherited are brewing in the cup. There are lots of classic tea types from the hilly land in Taiwan. Aborigines drink tea is originated from nature grace, inheritance of ancestors respect for the land.





看見

I See

作者姓名 Name of Designer(s)

李玟函

Wen-Han Li

指導老師 Instructor(s)

游明龍

Ming-Lung Yu

學校所在地 Location of School

臺灣

Taiwan

學校名稱 Name of School

亞洲大學

Asia University

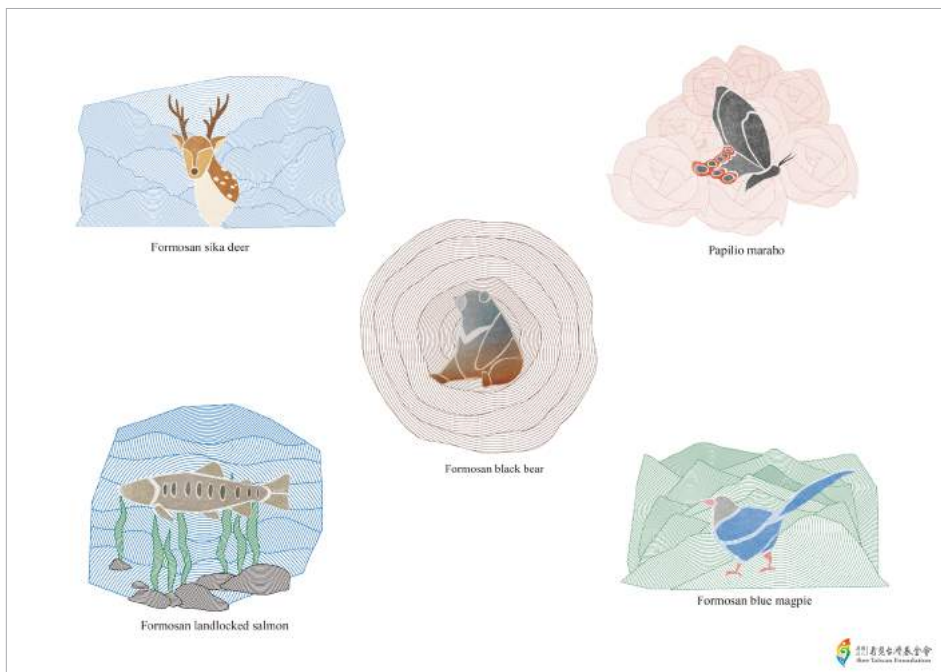

作品說明 Project Description

概念來源於贊助單位「看見台灣基金會」，因為是用於招待外賓之用，訴求第一眼就能透過茶具知道臺灣的人文特色，因此選用「看見」二字，意即看著茶具，見到臺灣。設計以臺灣的特有種為發想，分別是臺灣黑熊、臺灣藍鶯、寬尾鳳蝶、梅花鹿以及櫻花鉤吻鮭，將這些有特色的物種與茶盤做結合，喝茶的同時，亦能欣賞臺灣生態之美。

The concept of this design comes from the sponsor iSee Taiwan Foundation. This teaware is designed for better catering for a feast. You can really appreciate the beauty of Taiwan from these images. There are five Taiwanese endemic species which were chosen to combine with the tea trays. Such as the Formosan black bear, Papilio maraho, Formosan blue magpie, Formosan sika deer, and Formosan landlocked salmon.







### 若 / 茶則

If/tea

作者姓名 Name of Designer(s)

姜標、王新元、李嘉良、陳靜  
Biao Jiang, Xin-Yuan Wang,  
Jia-Liang Li, Jing Chen

指導老師 Instructor(s)

彭鐘  
Zhong Peng

學校所在地 Location of School

中國大陸  
China

學校名稱 Name of School

上海視覺藝術學院  
Shanghai Institute of Visual Arts



### 作品說明 Project Description

對於橫線來說，線上存在的高低起伏，就像它受到驚嚇；這也一如人生得寵、失寵的狀態，「寵辱若驚」對應著茶則的流暢之曲。但是，茶則的對稱之形，使其堅毅地挺立，訴說著它已然成熟，既柔且韌，「可寄託天下」。

For the horizontal line, there are ups and downs in the line, just like it's scared. This is the same as the grace of life, the state of being out of favor, the spoil of the shame and the smooth melody of the tea. But the symmetry of tea makes it stand erect, and say that it is mature, flexible and ready for the world.



## 寶島印象

### The Impression of Taiwan

作者姓名 Name of Designer(s)

朱璟欣、謝佳穎、潘思瀛  
Jing-Xin Choo, Jia-Ying Chia, Si-Hui Fua

指導老師 Instructor(s)

無

None

學校所在地 Location of School

馬來西亞  
Malaysia

學校名稱 Name of School

達爾尚藝術學院  
Dasein Academy of Art



#### 作品說明 Project Description

「瀑布、森林、溫泉」，世稱寶島「三絕」。此茶具的設計靈感來自臺灣多姿多彩的自然景觀與島國的地勢。設計中採用簡單的圖形與線條，形成三個分別代表了山林、瀑布與溫泉的繪圖，帶出臺灣樸實而迷人的自然之美。茶壺上的插畫山，河流源自於山，有如茶壺倒出的茶湯。茶杯呈的是茶湯，因此在茶杯上使用了河流與溫泉的插畫。

Waterfalls, forests and hot springs are three of the most precious natural resources of Taiwan. Inspired by the landscapes, simple line and shape are used in this design, forming illustrations re-presenting the mountains, rivers and hot springs to bring out the charming impression of Taiwan. Mountain is the source of river. The illustration shows the flow from mountain-river-hot spring, symbolizes the flow of tea being poured from the teapot into the teacup.





手搖·新食器

Shake! New Tea Bottle

作者姓名 Name of Designer(s)

林子翔

Tzu-Hsiang Lin

指導老師 Instructor(s)

翁註重

Ju-Joan Wong

學校所在地 Location of School

臺灣

Taiwan

學校名稱 Name of School

國立雲林科技大學

National Yunlin University of Science and Technology



作品說明 Project Description

來自東方的茶與西方的奶，加上粉圓，誕生出美味的珍珠奶茶。一杯珍珠奶，道出這塊島嶼各個時期文化交疊的縮影。將新石器時代的特色陶罐，運用現代手法融入茶飲的瓶罐設計，形成新舊交融的獨特造型，吸引旅客認識臺灣歷史，成為餐桌上的趣味話題。藉此，出土的文物不再只是冷冰冰地歷史資料；而是活生生乘載了這片土地上的過去、現在和未來。

Tea from the Eastern combined milk from the Western, with boba, created a delicious boba milk tea. A cup of bubble milk tea, represents the miniature of time and space cross cultures in this island. By using the potteries from the New Stone Age, can fully utilize the modern design of tea bottles, also blend the new and old unique style, to attract visitors to learn about history of Taiwan. This will bring on interesting topic for the dining table. Therefore, the cultural relics are not a insipid historical resource to us anymore, it is a living past of this land, stories of present and future.

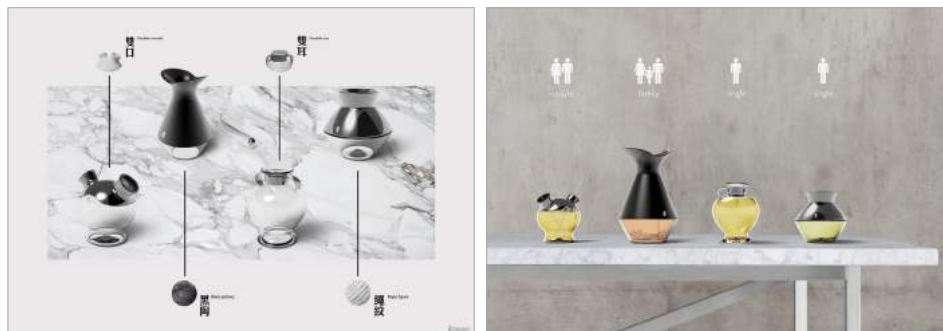

曲  
Curve

作者姓名 Name of Designer(s)

呂俊翰  
Jun-Han Lu

指導老師 Instructor(s)

朱玉麟  
Yu-Lin Chu

學校所在地 Location of School

臺灣  
Taiwan

學校名稱 Name of School

南臺科技大學  
Southern Taiwan University of Science  
and Technology



作品說明 Project Description

以一壺一杯為設計，由大自然生活中的曲線做發想，例如山脈、河流與石頭曲線。製作使用臺南安平傳統的陶瓷拉坯技術，手把使用臺灣原生檜木所製成，底部加上河洋隨處可見的鵝卵石作為支撐，並將臺灣的高山意象加到壺蓋上，使倒茶水時有著高山流水的意思，藉此表現臺灣豐富的自然環境與人文文化。

To a pot of a cup for the design, made by the curve of nature life, such as mountains, river and stone. Making the use of Tainan Anping traditional ceramic casting technology, made handles using Taiwan native cypress wood made of, plus river cobblestone as bottom support, and the image of Taiwan's alpine added to the lid. So that when pouring tea has lofty mountains and flowing water image, to show Taiwan's rich natural environment and human culture.

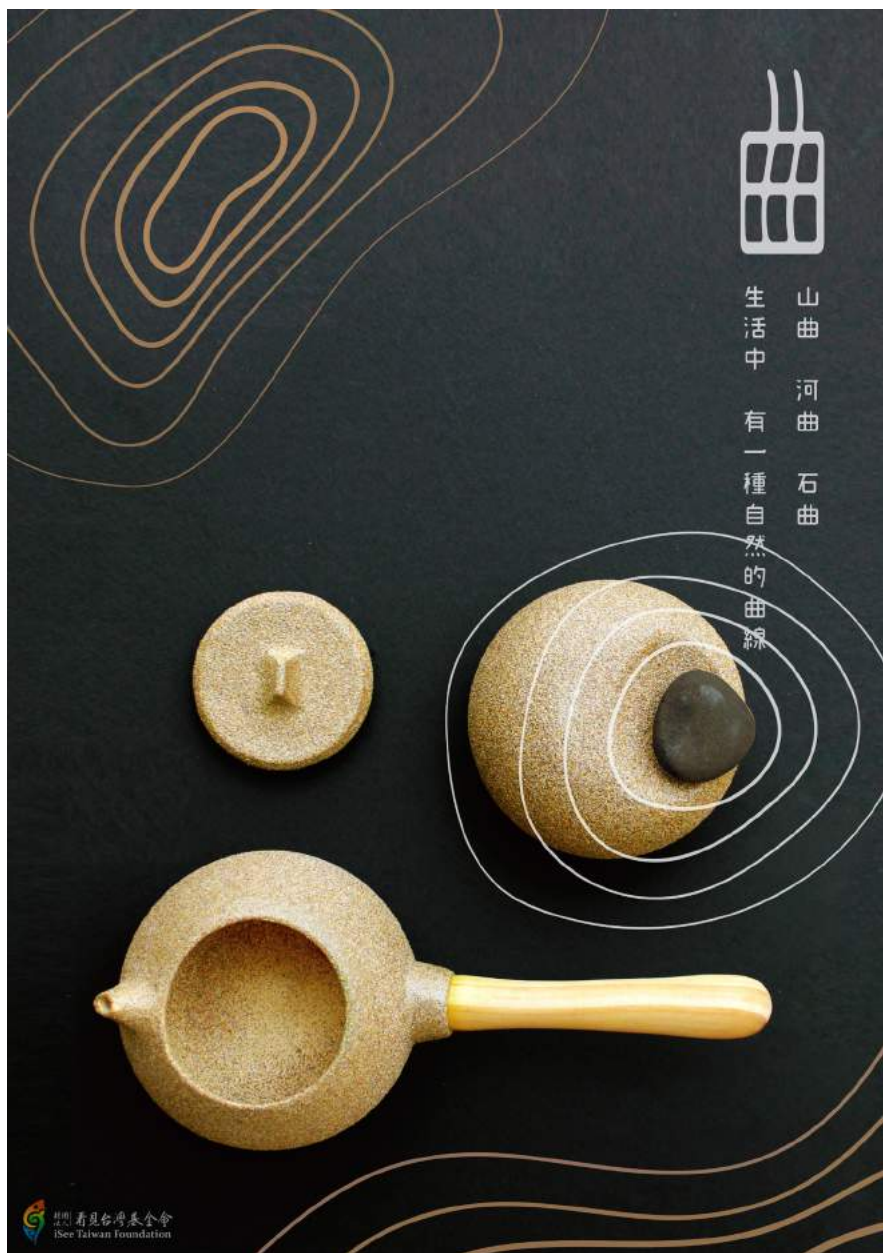



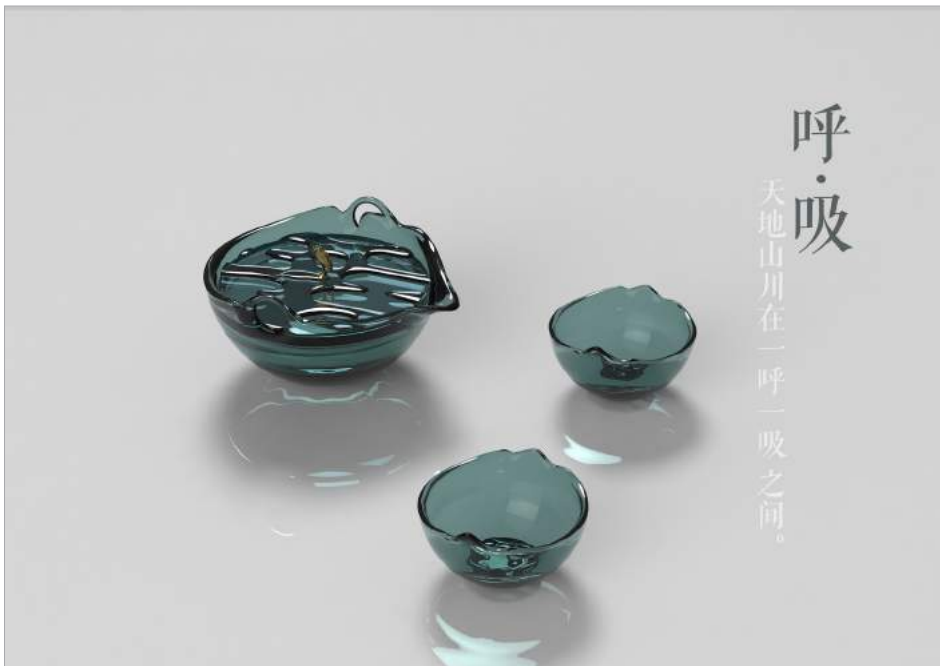

呼·吸

Breathing

作者姓名 Name of Designer(s)

賴玄、王思卿  
Xuan Lai, Si-Qing Wang

指導老師 Instructor(s)

林梓波  
Zi-Bo Lin

學校所在地 Location of School

中國大陸  
China

學校名稱 Name of School

福州大學廈門工藝美術學院  
Xiamen Academy of Arts and Design,  
Fuzhou University

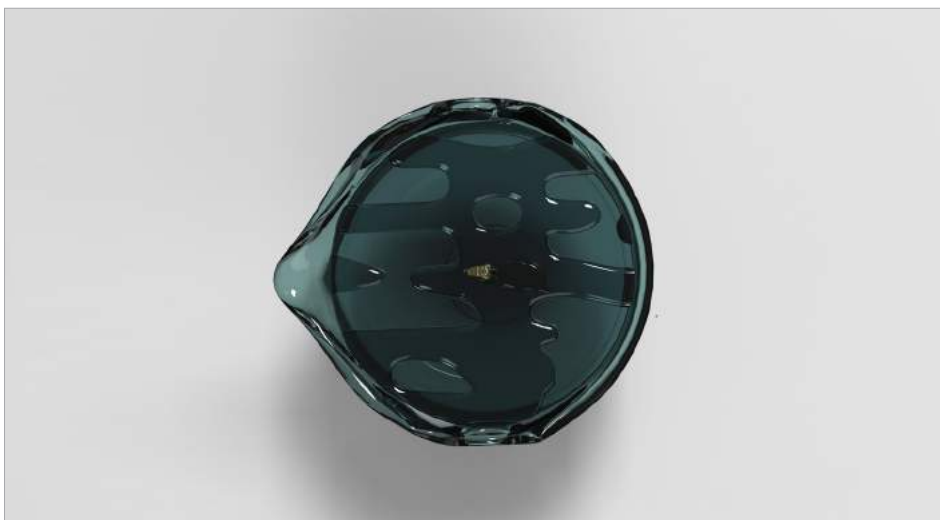

作品說明 Project Description

天地山川在一呼一吸之間。山呼吸，綿延成山脈。遠山長，雲山亂，曉山青，兩側的耳鈕為臺灣山脈，鏤空部分象徵日月潭。水呼吸，蕩漾出波紋。上善若水，壺鈕是野柳地質公園的女王頭，整個臺灣島漂浮在水面上，隨著水的呼吸，起起伏伏。

All things are in a breath. The mountain breathe and stretch into mountains, the two sides of the ear button for the Taiwan mountains, hollowed out part of the symbol of Riyuetan Pool. Water breathing, rippling out ripples, pure kindness like water, pot button is wild willow geology park king head, the whole island of Taiwan floating in the water, with the water breathing, ups and downs.

## 山中香，湖中水 Aroma from the Mountain, Taste from the Lake

作者姓名 Name of Designer(s)

湯睿峰、劉耀鍾

Jui-Feng Tang, Yao-Chung Liu

指導老師 Instructor(s)

陳彥廷、范成浩

Yan-Ting Chen, Cheng-Hao Fan

學校所在地 Location of School

臺灣

Taiwan

學校名稱 Name of School

國立臺灣科技大學、國立臺灣藝術大學  
National Taiwan University of Science  
and Technology、National Taiwan  
University of Arts



### 作品說明 Project Description

雙杯品茗法為臺灣特有的泡茶特色，透過有趣的泡茶過程，讓外國賓客體驗臺灣特色的品茶方式。外觀上呈現著由阿里山流入湖泊的山泉水，水氣環繞著山峰，宛如阿里的雲海般，讓賓客享受具有臺灣風格的茶饗宴。

Enjoying the tea with two cups is Taiwanese own tradition. We can make foreign visitor experience the unique way to drink tea with this interesting way making tea. By the vapor of the hot tea, we want to present for the drinkers the magnificent sea of clouds on A-li Mountain. Giving the drinkers not only the visual experience but also the smell experience.



雙杯品茗法為臺灣特有的泡茶特色，透過有趣的泡茶過程，讓外國賓客體驗臺灣特色的品茶方式。外觀上呈現著由阿里山流入湖泊的山泉水，水氣環繞著山峰，宛如阿里的雲海般，讓賓客享受具有臺灣風格的茶饗宴。

Enjoying the tea with two cups is Taiwanese own tradition. We can make foreign visitor experience the unique way to drink tea with this interesting way making tea. By the vapor of the hot tea, we want to present for the drinkers the magnificent sea of clouds on A-li Mountain. Giving the drinker not only the visual experience but also the smell experience.

### 雙杯品茗

雙杯品茗法始於臺灣，均在八〇年代成形，九〇年代流行於亞太地區華人圈、日本、韓國烏龍茶愛好者之間。講究的是每人使用兩只茶杯，一高杯一矮杯，高杯稱為「聞香杯」，矮杯為「入口杯」。是一種適合輕皮發酵茶的品飲方式，雙杯品茗法的出現是臺灣茶文化的重要發展特色。

#### Enjoy the tea with two cups

This tradition is originated in Taiwan. It became mature in 1980. This tradition was popular with the tea lovers lived in Asia-Pacific zone. It is famous for it two cups, the tall cup and the short one. The taller is called Teacup for smelling, and the short one is called Teacup for drinking. It suit to the tea lovers who love to drink lightly fermented tea. This tradition becomes one of the important way for drinking tea in Taiwan.



高杯聞香

矮杯入口

#### 聞香杯：

造型為阿里山山峰，意味著山中帶來的香氣，材質為玻璃隔熱雙層杯，免去了聞香杯以往燙手之特性。

#### Teacup for smelling :

The shape is inspired by the shape of A-li Mountain. It main we bring the aroma from the tea that we grow on the A-li Mountain. The material of this cup is transparent ceramics, and the cup is designed in two layer which can prevent the drinker from the heat.



#### 入口杯：

有著潤滑的功能性，承接著高山流下東水，經過大地的滋養，甘甜的滋味，讓人無法忘懷。

#### Teacup for drinking :

The color of the cup is designed from the lake which come from A-li Mountain. This cup symbolize the lake made by A-li Mountain. Water from A-li Mountain can make the tea more sweet and flavous.



山中香湖中水



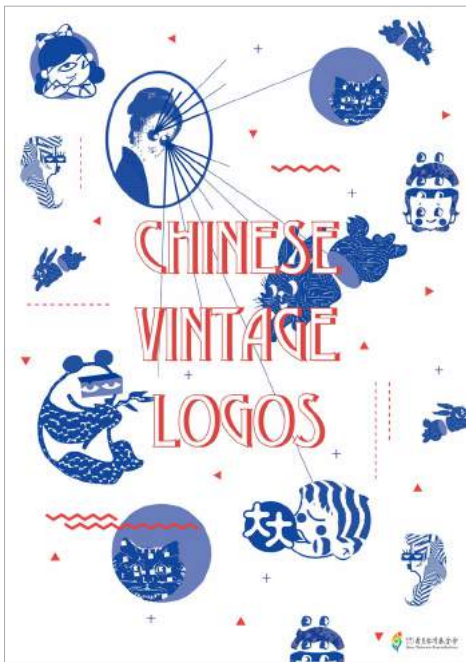

### 老商標新創意

## Translate Legacy Logo into State of The Art - Cultural Creative Product Design

作者姓名 Name of Designer(s)

尚爽

Shuang Shang

指導老師 Instructor(s)

姚翔宇、沈蘭

Xiang-Yu Yao, Lan Shen

學校所在地 Location of School

中國大陸

China

學校名稱 Name of School

南京藝術學院

Nanjing University of the Arts



### 作品說明 Project Description

中國 80、90 年代國貨盛行，它們的商標設計有許多值得我們借鑒的地方。故我選擇了部分具有代表性的國貨商標，即大白兔、恒源祥、白貓、謝馥春、熊貓這些商標作為我的設計素材，將其進行再設計做出了復古又新潮的新商標。我又根據新商標設計出瓷器紋案，親自貼花並燒窯，最終制成衍生品—純手工貼花燙金瓷盤及瓷杯。此套瓷是平面設計與陶瓷藝術的結合，它將平面設計通過陶瓷這壹載體嶄新地呈現於觀者眼前，它讓觀者意識到，老國貨也可有新設計，藝術也可多元化。我希望瓷具上的元素能在喚醒兩岸同胞懷舊記憶的同時又能被賦予新時代平面設計的特點，借此呼籲兩岸人民共同支持國貨，並攜手將中國優秀的產品及博大精深的傳統文化推廣給全世界。

I designed 8 logos and other cultural creative products derived from the logos – 6 porcelain dishes and 3 porcelain cups. New logos were re-designed based on Chinese legacy logos. Porcelain has adopted pure hand decals of gold foil process, made by firing kiln. The works have given legacy logo new spirit; It shows traditional Chinese goods can have a new look. The Works not only call on people to support domestic products, but also hopefully spread the traditional Chinese culture to the world.



回甘好麻吉

**Aftertaste Buddies**

作者姓名 Name of Designer(s)

林姿妤、林總蘋  
Zih-Yu Lin, Si-Pin Lin

指導老師 Instructor(s)

游明龍  
Ming-Lung Yu

學校所在地 Location of School

臺灣  
Taiwan

學校名稱 Name of School

亞洲大學  
Asia University



作品說明 Project Description

將臺灣特有動物有趣味的表現手法呈現。回甘好麻吉有知心好友就像茶一般，濃醇香，且回甘的意思。

Taiwanese animals with interesting painting techniques. Aftertaste Buddies meaning best friends like tea, rich and mellow and aftertaste.

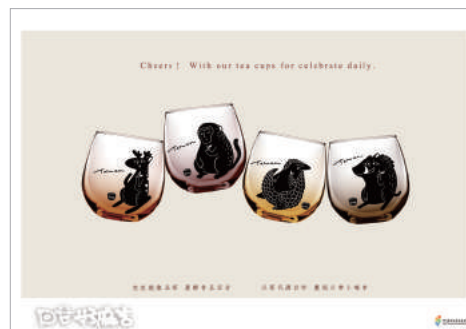
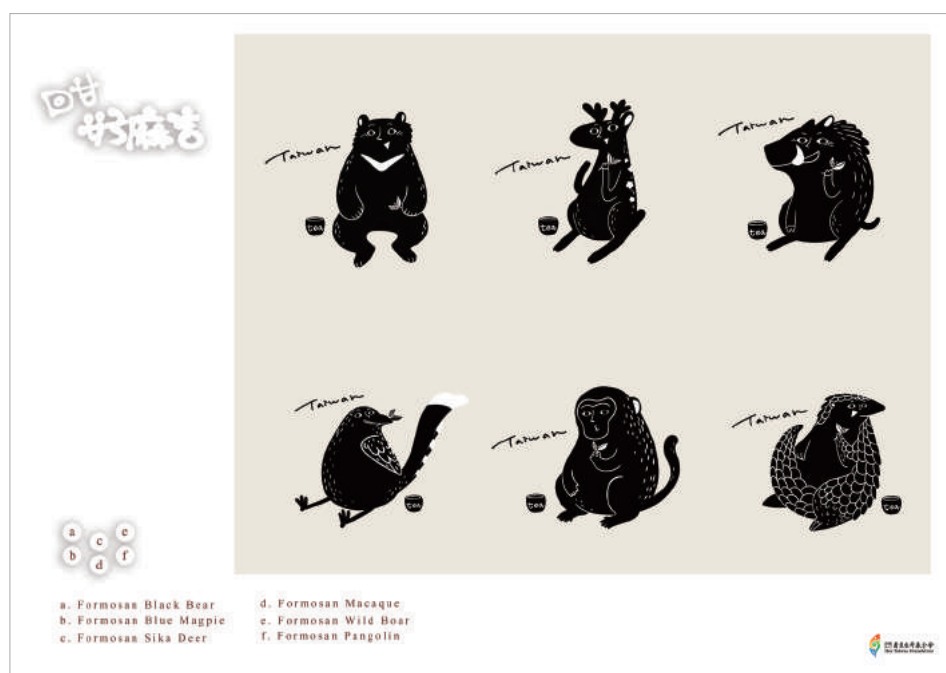



## 大寒不寒

### The Warmful Major Cold

作者姓名 Name of Designer(s)  
謝家瑄、陳郁蓉、黃沛碗  
Chia-Hsuan Hsieh, Yu-Rong Chen,  
Pei-Wan Huang

指導老師 Instructor(s)  
徐子雲  
Zi-Yun Xu

學校所在地 Location of School  
臺灣  
Taiwan

學校名稱 Name of School  
國立臺中科技大學  
National Taichung University of Science and  
Technology



看到茶壺冒出的煙，  
就好像嗅到家裡電鍋蒸著媽媽煮的熱騰騰的飯，  
大同電鍋是台灣人共同的記憶，  
也是能代表家鄉味和濃濃溫情的物件。

Seeing the smoke from the teapot,  
just as if sniffing the steaming hot rice from the electric cooker in home.  
TATUNG electric cooker is the common memory of Taiwanese,  
and also the object that represent the warmth and the taste of home.

## 來自家鄉的煙

### The Smoke Carrier

作者姓名 Name of Designer(s)  
蕭郁馨  
Yu-Hsin Hsiao

指導老師 Instructor(s)  
徐子雲、魏明仕  
Tzu-Yun Shu, Ming-Shih Wei

學校所在地 Location of School  
臺灣  
Taiwan

學校名稱 Name of School  
國立臺中科技大學  
National Taichung University of Science and  
Technology



## 尊爵

### Ancient Drinking Vessel

作者姓名 Name of Designer(s)  
謝凱文  
Kai-Wen Hsieh

指導老師 Instructor(s)  
楊忻彪、陳清汶  
Hsin-Piao Yang, Ching-Wen Chen

學校所在地 Location of School  
臺灣  
Taiwan

學校名稱 Name of School  
東方設計大學  
Tung Fang Design University

印象

Impression

作者姓名 Name of Designer(s)

王心穎

Hsin-Ying Wang

指導老師 Instructor(s)

李新富

Shin-Fu Lee

學校所在地 Location of School

臺灣

Taiwan

學校名稱 Name of School

亞洲大學

Asia University



好聚\_好句

Hao Ju Hao Ju

作者姓名 Name of Designer(s)

林姿妤、林總蘋

Zih-Yu Lin, Si-Pin Lin

指導老師 Instructor(s)

游明龍

Ming-Lung Yu

學校所在地 Location of School

臺灣

Taiwan

學校名稱 Name of School

亞洲大學

Asia University



車程

Chèchéng

作者姓名 Name of Designer(s)

蔡雅竹、黃婉婷、阮翊雲、傅盛華、

吳秉修

Ya-Chu Tsai, Wan-Ting Huang, Yi-Yun Ruan,

Sheng-Hua Fu, Bing-Shiou Wu

指導老師 Instructor(s)

林孟潔

Miira Lin

學校所在地 Location of School

臺灣

Taiwan

學校名稱 Name of School

亞洲大學

Asia University

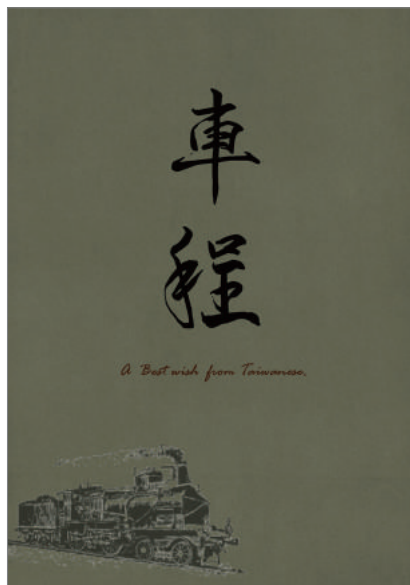



### Tea Set of Mountains and Rivers

#### 臺灣山水杯

臺灣是一個多山的島嶼，山地的面積幾乎佔全島面積的2/3以上，分布超過275座海拔3,000公尺（9,800英尺）以上高峰，是全世界高山密度最高的島嶼之一，而其中最高的玉山主峰頂，海拔3,952公尺。（數據資料來源引自維基百科）。



### 台灣山水杯

#### Taiwan Mountain Cup

作者姓名 Name of Designer(s)

陳姿廷

Tzu-Ting Chen

指導老師 Instructor(s)

李新富、侯純純

Shin-Fu Lee, Chun-Chun Hou

學校所在地 Location of School

臺灣

Taiwan

學校名稱 Name of School

國立臺中科技大學

National Taichung University of Science and Technology



### 茶憩

#### Take a Tea Rest

作者姓名 Name of Designer(s)

賴家愛、黃子華、楊旰柔、魏子修、劉詩婷、余佳珈

Chia-Ai Lai, Tzu-Hua Huang, Cian-Rou Yang, Zih-Siou Wei, Shih-Ting Liu, Jia-Jia Yu

指導老師 Instructor(s)

廖偉民

Melvyn Liao

學校所在地 Location of School

臺灣

Taiwan

學校名稱 Name of School

國立臺灣大學

National Taiwan University



以台灣夜市的人潮與霓虹招牌為主，表現出台灣夜晚的熱鬧。

### 茶夜

#### Tea Night

作者姓名 Name of Designer(s)

許雅媛、江采婷

Ya-Yuan Hsu, Tsai-Ting Chiang

指導老師 Instructor(s)

游明龍

Ming-Lung Yu

學校所在地 Location of School

臺灣

Taiwan

學校名稱 Name of School

亞洲大學

Asia University

留下

Stay

作者姓名 Name of Designer(s)

張巧竹、林威辰、陳宗賢  
Ciao-Jhu Jhang, Wei-Chen Lin,  
Zong-Xian Chen

指導老師 Instructor(s)

吳湘萍、易佑安  
Hsiang-Ping Wu, Yu-An Yi

學校所在地 Location of School

臺灣

Taiwan

學校名稱 Name of School

東南科技大學  
Tungnan University



宋人的茶室

Teaware

作者姓名 Name of Designer(s)

梁晨  
Chen Liang

指導老師 Instructor(s)

張克非  
Ke-Fei Zhang

學校所在地 Location of School

德國

Germany

學校名稱 Name of School

漢堡美術學院  
University of Fine Arts of Hamburg



八家將

The Eight Police Officers

作者姓名 Name of Designer(s)

陳燕儀、李唯誌、古羽恩、鄭思晏、  
陳昱穎

Yan-Yi Chen, Wei-Chih Lee, Yu-En Ku,  
Si-Min Cheng, Yu Yin Chen

指導老師 Instructor(s)

翁永圳  
Jeff Wong

學校所在地 Location of School

臺灣

Taiwan

學校名稱 Name of School

醒吾科技大學  
Hsing Wu University of Science and  
Technology











煌煌臺茶  
Huanghuang Tea Set

作者姓名 Name of Designer(s)  
鄧文杰、黎奕君、張君豪  
Wen-Jie Deng, Yi-Jun Li, Jun-Hao Zhang

指導老師 Instructor(s)  
李硯祖  
Yan-Zu Li

學校所在地 Location of School  
澳門  
Macau

學校名稱 Name of School  
澳門科技大學  
Macau University of Science and Technology



天鵝壺  
Swan Pot

作者姓名 Name of Designer(s)  
張潤潤、孟丹丹  
Run-Run Zhang, Dan-Dan Meng

指導老師 Instructor(s)  
王愛紅  
Ai-Hong Wang

學校所在地 Location of School  
中國大陸  
China

學校名稱 Name of School  
景德鎮陶瓷大學  
Jingdezhen Ceramic Institute



阿里山水  
Ali Landscape

作者姓名 Name of Designer(s)  
張潤潤  
Run-Run Zhang

指導老師 Instructor(s)  
王愛紅  
Ai-Hong Wang

學校所在地 Location of School  
中國大陸  
China

學校名稱 Name of School  
景德鎮陶瓷大學  
Jingdezhen Ceramic Institute

茶吃後來齏

Drink a Cup of Tea and Listen to the Story

作者姓名 Name of Designer(s)

陸蕙婷

Yee-Teng Loke

指導老師 Instructor(s)

Deanie Cham

學校所在地 Location of School

馬來西亞

Malaysia

學校名稱 Name of School

達爾尚藝術學院

Dasein Academy of Art

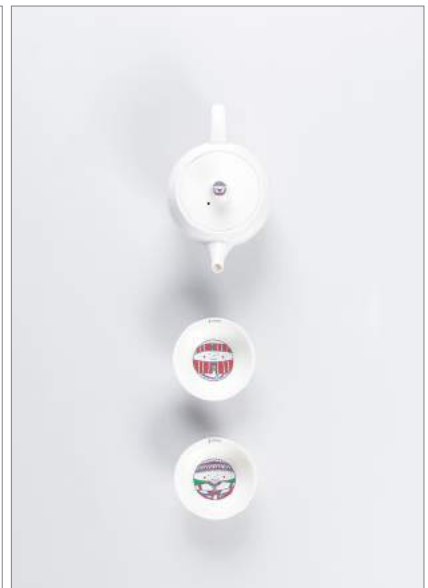
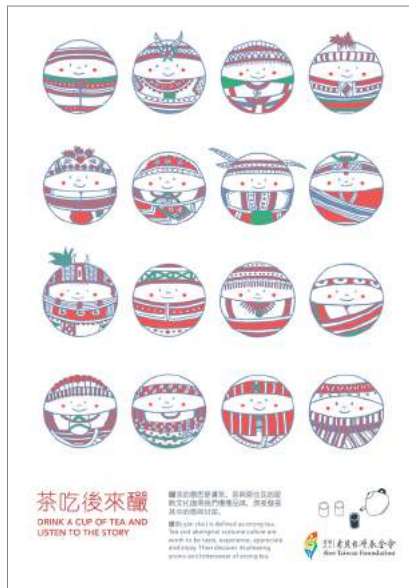

山河戀

Love Between Mountains and Rivers

作者姓名 Name of Designer(s)

張玉磊

Yu-Lei Zhang

指導老師 Instructor(s)

溫國勳

Kuo-Hsun Wen

學校所在地 Location of School

澳門

Macau

學校名稱 Name of School

澳門科技大學

Macau University of Science and Technology

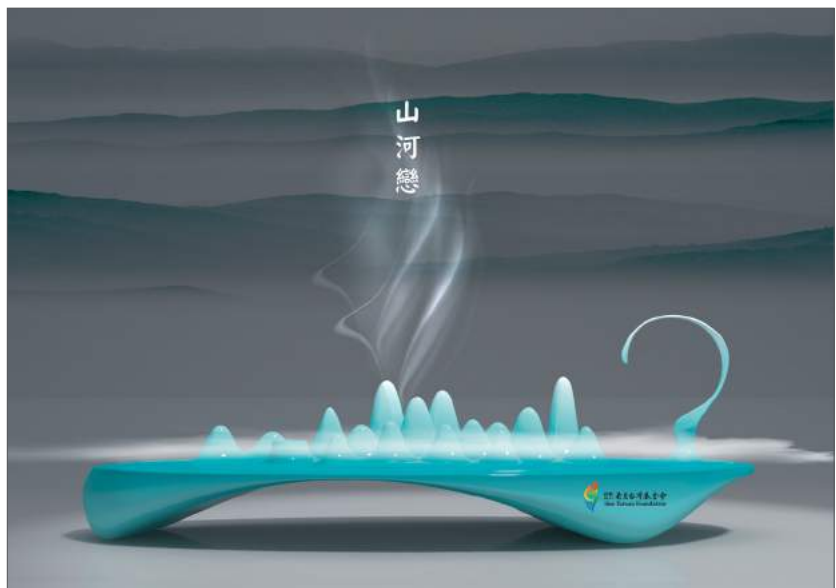

岸

Shore

作者姓名 Name of Designer(s)

簡嘉苗、肖若梅、王瑩、曾瑩瑩

Jia-Miao Jian, Ruo-Mei Xiao,

Ying Wang, Ying-Ying Zeng

指導老師 Instructor(s)

金優石

Wooseok Kim

學校所在地 Location of School

中國大陸

China

學校名稱 Name of School

福州大學

Fuzhou University







**波霸奶茶**  
**Boba Milk Tea**

作者姓名 Name of Designer(s)  
鄧超穎  
Chao-Ying Deng

指導老師 Instructor(s)  
劉羽  
Yu Liu

學校所在地 Location of School  
中國大陸  
China

學校名稱 Name of School  
天津科技大學  
Tianjin University of Science & Technology



**壹零壹壺**  
**101 Pot**

作者姓名 Name of Designer(s)  
張潤潤  
Run-Run Zhang

指導老師 Instructor(s)  
無  
None

學校所在地 Location of School  
中國大陸  
China

學校名稱 Name of School  
景德鎮陶瓷大學  
Jingdezhen Ceramic Institute



**桐花在臺灣**  
**Tung Flowers in Taiwan**

作者姓名 Name of Designer(s)  
廖祥翔  
Xiang-Xiang Liao

指導老師 Instructor(s)  
洪啟慧、黃星源  
Xin-Hui Hong, Xing-Yuan Huang

學校所在地 Location of School  
中國大陸  
China

學校名稱 Name of School  
福州大學  
Fuzhou University







## 樺卯茶器

### Chapeng

作者姓名 Name of Designer(s)

翟偉民、徐樂、林幸民

Wei-Min Zhai, Le Xu, Xing-Min Lin

指導老師 Instructor(s)

無

None

學校所在地 Location of School

中國大陸

China

學校名稱 Name of School

東北林業大學

Northeast Forestry University



## 層層高

### Up & Up

作者姓名 Name of Designer(s)

涂征宇

Zheng-Yu Tu

指導老師 Instructor(s)

無

None

學校所在地 Location of School

德國

Germany

學校名稱 Name of School

薩爾藝術學院

Saar College of Fine Arts

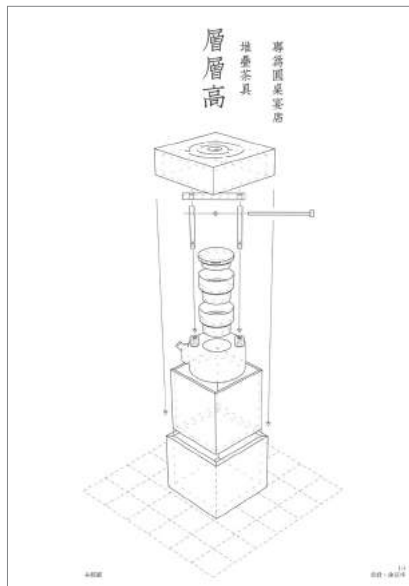



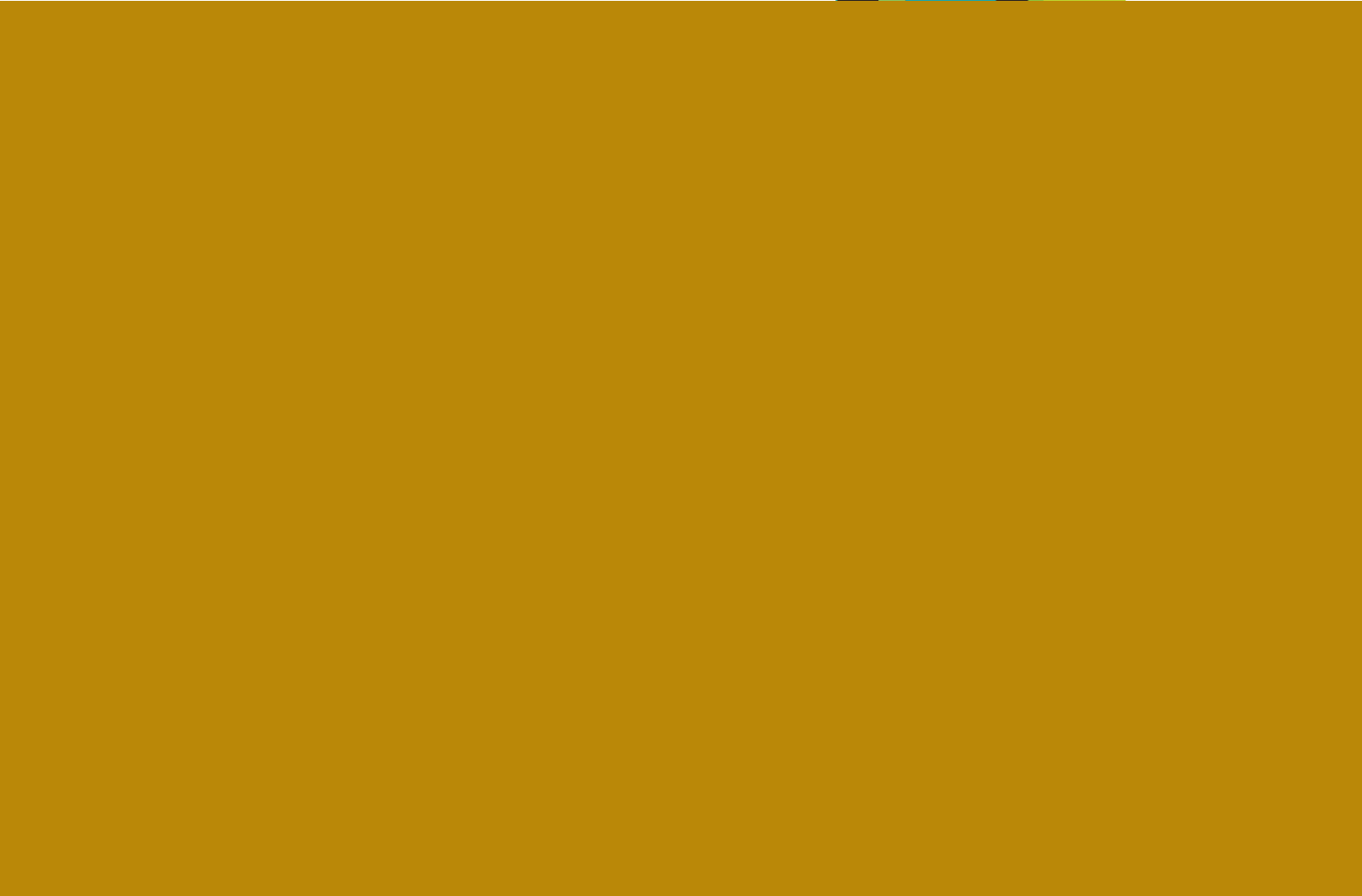





2017

# Opportunity

---

評審介紹

Jury Introduction

## 評審介紹 Jury Introduction

### 產品設計 Product Design



召集人  
*The Convener of Judging Panel*

#### 張漢寧 Jimmy Chang | 臺灣 Taiwan

- 中華民國工業設計協會理事
- 2011 世界設計大會入選 臺灣百大設計師
- 2016 臺北世界設計之都「設計進站」策展人
- 臺南市政府文化局「臺南文創中心」主持人
- 擔任「2017 世界大學運動會 火炬、母火燈、駐火臺設計製作」總設計師
- CIDA / Member of Board
- 2011 World Design Expo / Top 100 Designers
- 2016 World Design Capital / Curator of "Design Station"
- Tainan City Government, Cultural Affairs Bureau / Creative Plus chief director
- 2017 Universiade Summer Game / The Torch, Safety Lantern, Lamp Table chief designer



初 / 決選評審  
*Juror of Preliminary / Final Stage*

#### 鍾雅涵 Kate Chung | 臺灣 Taiwan

- KateChungDesign 設計師 / 設計總監
- 榮獲 Design Plus / Good Design Award / Design for Asia Award / 臺灣文創精品獎
- 曾任品家家居設計總監
- 曾任橙果設計資深設計師
- 義大利 Domus 設計學院碩士
- KateChungDesign Designer / Design Director
- Awarded by Design Plus / Good Design Award / Design for Asia Award / Cultural & Creative Award
- Worked in JIA Inc. as Design Director
- Worked in DEM Inc. as Senior Designer
- Domus Academy, Master of Design



初審評審  
*Juror of Preliminary Stage*

#### Ashish Deshpande | 印度 India

- 印度設計師協會總監
- 以工業設計師身分獲邀至日本優良設計獎加入評審團，同時也是 2017 年坎城國際創意節產品設計類別當屆評審
- 活躍於亞洲設計連
- 2016 年於韓國羅州創新城舉辦的世界環保設計展覽會，擔任國際專題研討會中的主題獎者
- 他與 Elephant 團隊獲頒無數獎項，其中囊括美國的 Spark 及美國 Greener Gadgets 獎，以及 CII 設計卓越獎，其他 5 項產品也獲印度設計標誌獎
- President, Association of Designers of India
- As Industrial Designer, he was invited to attend Good Design Mark Jury Process, Japan and is present Product Design Jury for Cannes Lions 2017
- An Active Member of the Design Alliance Asia
- Delivered Keynote at International Symposium, Naju Innovation City, Korea, 2016 World Eco-friendly Design Expo
- He & team at Elephant is recipient of several awards including Spark (USA), Greener Gadgets (USA), CII-Design Excellence and 5 products received the India Design Mark



初審評審  
*Juror of Preliminary Stage*

**孫崇實 Chung-Shih Sun** | 臺灣 Taiwan

- 器研所共同創辦人 / 研發總監
- 2015 金點設計獎年度最佳設計、德國紅點設計獎
- 2014 金點設計獎年度最佳設計、德國 iF 產品設計獎
- 2013 臺北國際電腦展創新設計獎、SDA 設計大賞最佳設計團隊
- 2012 金點設計獎年度最佳設計、德國紅點設計獎、臺北國際電腦展創新設計獎
- 2011 臺灣文創精品獎金獎、日本 G-Mark 設計獎、德國 Red Dot 首獎
- Co-Founder, R&D Director of Gearlab
- 2015 Golden Pin Design Award Best Design of the Year, Red Dot Design Award
- 2014 Golden Pin Design Award Best Design of the Year, iF Product Design Award
- 2013 COMPUTE X Taipei d&i Awards, Shopping Design Award 2013 Taiwan BEST100
- 2012 Golden Pin Design Award Best Design of the Year, Red Dot Design Award, COMPUTE X Taipei d&i awards
- 2011 Cultural & Creative Award Gold Award, G-Mark Good Design Award, 2011 Red Dot Design Award



初審評審  
*Juror of Preliminary Stage*

**吳孝儒 Pili Wu** | 臺灣 Taiwan

- 吳氏設計有限公司 PiliWu-Design 創辦人
- 2016 臺灣金點設計獎
- 2015 Design for Asia Award 亞洲影響力大獎、2015 德國 If 設計獎
- 2014 日本 Good Design Award 大獎
- 2013 提名於日本東京設計師週 Asia Award
- Founder, PiliWu Design Studio
- 2016 GoldenPin Award
- 2015 IF design Award, 2015 Design For Asia Award - Culture Award
- 2014 Good Design Award (Japan)
- 2013 Tokyo Design Week - Asia Award - Nominate (Tokyo, Japan)



初審評審  
*Juror of Preliminary Stage*

**鄭洪 Tom Cheng** | 臺灣 Taiwan

- 同樂工作室負責人
- BLACK TAILORS 共同創辦人
- 設計 Design 雜誌特約外稿
- 中華民國工業設計協會理事
- 榮獲德國 iF 獎金獎、德國紅點設計獎、美國 IDEA 設計獎銀獎、香港 DFA 亞洲最具影響力卓越獎、臺灣文創精品獎、臺灣金點設計獎
- TWO+ LAB / Founder
- BLACK TAILORS / Co- Founder
- Design Magazine / Contributor
- CIDA / Member of Board
- Awarded by iF Design Award / Reddot Award / IDEA award / DFA Award / Cultural & Creative Award / Golden Pin Design Award



## 評審介紹 Jury Introduction

### 產品設計 Product Design



初審評審  
*Juror of Preliminary Stage*

#### 林同利 **Tong-Li Lin** | 臺灣 Taiwan

- 台灣優良設計協會秘書長 2003 年 - 至今
- 台灣創意設計中心前副執行長
- 2015 臺灣國際學生創意設計大賽初決選評審委員召集人
- 臺灣新一代設計獎策劃人初決選評審委員 2003 至今
- 2015-2017 年海峽工業設計大獎賽評獎委員會副主任暨初決選評審委員
- Secretary-General of Taiwan Good Design Association, 2003-2017
- Taiwan Design Center, former Deputy CEO
- The Chief Adjudicator jury of Taiwan International Student Design Competition, 2015
- The Planner and jury of Taiwan Young Designers' Award, 2003-2017
- The Deputy Director and Jury of Cross-Strait Industrial Design Awards Committee, 2015-2017



初審評審  
*Juror of Preliminary Stage*

#### 林厚進 **Kevin Lin** | 臺灣 Taiwan

- 賽先生科學工廠創辦人
- 玉馬門創意設計有限公司設計總監
- 台灣設計協會 國際交流主委
- 2014 日本 Good Design 得獎
- 2014 德國 iF 傳達設計獎
- Founder of Mr. Sci Science Factory
- Design Director of Yumaman Creative & Design
- Minister for Foreign Affairs of Taiwan Amoeba Design Association (TADA)
- Good Design Award 2014
- iF Design Award 2014



決審評審  
*Juror of Final Stage*

#### **Anurak Suchat** | 泰國 Anurak Suchat

- 榮獲五屆日本優良設計大獎
- 榮獲六屆泰國 Demark 設計大獎
- 2009-2011 連續三年獲得泰國總理頒發最佳出口獎之殊榮
- 2010-2011 榮獲兩屆新加坡國際家具展大賽
- 5 Good Design Award, Japan
- 6 Demark Award, Thailand
- 3 Years for Prime Minister Export Award, Thailand (2009-2011)
- 2 Awards from International Furniture Fair, Singapore (2010-2011)



決審評審  
*Juror of Final Stage*

**Brandon Gien** | 澳洲 Australia

- 澳大利亞優秀設計協會執行長
- 世界設計組織中國際工業設計學會理事
- 澳洲坎培拉大學工業設計教授
- CEO, Good Design Australia
- Senator, ICSID, World Design Organization; Adj
- Professor, Industrial Design, University of Canberra, Australia



決審評審  
*Juror of Final Stage*

**鄭道成 Do Sung Chung** | 韓國 Korea

- 韓國國民大學設計與工藝研究所院長，韓國國民大學技術設計研究所院長
- KIAD 工業設計協會理事長
- Fukuda 設計公司首席設計師
- Toyoguchi 設計協會設計師
- JSSD 日本設計協會會員
- KSBDA 韓國設計協會會員
- Head of Graduate School of Design & Craft Education and Techno Design, Kookmin University
- President of Korea Association of Industrial Designers
- Chief Designer, Fukuda Design Limited
- Designer, Toyoguchi Design Institute
- Member of Japanese Society for Science of Design
- Member of Korean Society of Basic Design & Art



決審評審  
*Juror of Final Stage*

**Hridaysh Deshpande** | 印度 India

- 擔任 Ajeenkya DY Patil 大學董事會成員
- 擔任 DYPDC 設計學院、電影及多媒體學院等學院主任
- 擔任印度設計委員會 (IDC) 顧問
- 2013-2015 擔任日本 Good Design Awards 評審
- CII 全國委員會設計部門之會員
- Member of Governing Body of Ajeenkya DY Patil University
- Director of DYPDC School of Design and School of Film and Media
- India Design Council (IDC) Consultant Advisor
- Jury member at Good Design Awards, Japan (2013-2015)
- Member of CII National Committee on Design

## 評審介紹 Jury Introduction

### 產品設計 Product Design



決審評審  
Juror of Final Stage

#### Janine Wunder | 德國 Germany

- Rat für Formgebung 德國設計協會市場營銷副會長
- 長期擔任各設計大賽副會長：德國設計大賽、汽車品牌大賽、標誌創新建築、德國品牌大獎等等
- 研究文化產業與經濟，並擔任法蘭克福展覽藝術博覽會專案經理
- 組織數次設計展覽，如代表德國聯邦外交部偕同舉辦的米蘭設計三年展和倫敦設計雙年展
- 擁有豐富的设计獎和新人獎評審經驗
- Vice President Communications and Marketing, Rat für Formgebung | German Design Council
- Long-term experience as Vice President Design Awards: German Design Award, Automotive Brand Contest, Iconic Awards Innovative Architecture, Iconic Awards, Innovative Interior, German Brand Award etc.
- Studied Cultural Industries and Economy and Worked as Project Manager for the Art Fairs at Messe Frankfurt
- Organized Several Design Exhibitions Such as the German Contributions for the Triennale di Milano and the London Design Biennale on behalf of the Federal Foreign Office of Germany
- Experienced in Jury Work for Design Awards and Newcomer Awards



決審評審  
Juror of Final Stage

#### 青木史郎 Shiro Aoki | 日本 Japan

- 日本設計振興會資深顧問、前執行董事、首席營運總監
- 東京藝術大學客座教授
- 1989 任職國家設計促進活動秘書處
- 著有《工業設計講座 - 工業社會設計發展與未來展望》一書
- 致力於促進中小企業，發展當地社區與國際合作等
- Senior Counselor, Past Executive Director, COO of Japan Institute of Design Promotion
- Affiliate Professor of Tokyo University of the Arts
- Secretariat of Nation Wide Design Promotion Campaign(1989)
- Author of 《The lecture of Industrial Design - Development of Design in Industrial Society and Near-Future Outlook》
- Promotion of SMEs, Development of Local communities, International Cooperation, etc.



決審評審  
Juror of Final Stage

#### 孫善蓉 Steffy Sun | 臺灣 Taiwan

- 國立臺灣藝術大學造型藝術研究所畢業
- 台灣創意設計中心設計推廣組組長
- 台灣創意設計中心設計出版組組長
- 2014-2017 統籌策劃「金點設計獎」系列活動
- 2015-2017 統籌策劃「金點概念設計獎」及「金點新秀設計獎」系列活動
- 2017 統籌「臺灣文博會」交流晚宴 - “春之家宴”
- Master Degree of Plastic Arts, National Taiwan University of Arts
- Coordinator of General Promotion Section of Taiwan Design Center
- Coordinator of Design and Publishing Section of Taiwan Design Center
- Curator of Golden Pin Design Award Campaign (2014-2017)
- Curator of Golden Pin Concept Design Award and Young Pin Design Award Campaign (2015-2017)
- Curator of Cultural and Creative Award Ceremony - Family Banquet in Spring (2017)





召集人  
*The Convener of Judging Panel*

章琦玫 **Chi-Mei Chang** | 臺灣 Taiwan

- 中華平面設計協會理事長
- 十分視覺整合設計有限公司創意指導
- 國立臺灣藝術大學視覺傳達設計系兼任講師
- 2016 金點設計評審委員
- 2017 臺北世界大學運動會整體賽會視覺設計審查委員
- President of Taiwan Graphic Design Association
- Creative Director of Optima Integrated Design
- Instructor of National Taiwan University of Arts
- Judge of 2016 Golden Pin Design Award
- Committee Member of the XXIX Summer Universiade



初 / 決選評審  
*Juror of Preliminary / Final Stage*

楊佳璋 **Martin Yang** | 臺灣 Taiwan

- 中華平面設計協會輔導理事長
- TDA 台灣設計聯盟理事
- 中華民國工業設計協會常務理事
- 樞致形象設計有限公司創意總監 / 負責人
- 臺灣文化創意產業聯明協會理事
- Taiwan Graphic Design Association, Honorary President
- Taiwan Design Alliance, Director
- Chinese Industrial Designers Association, Executive Director
- HWAT's Graphic Design co., Ltd., Creative Director / Chairman
- Taiwan Cultural and Creative Industry Association, Director



初審評審  
*Juror of Preliminary Stage*

黃家賢 **Andrew Wong** | 臺灣 Taiwan

- 洋蔥設計負責人
- 入圍第 57 屆葛萊美獎「最佳唱片包裝」
- 入圍 25, 27 屆金曲獎「最佳專輯包裝獎」
- 學學文創 Typography 講師
- 田田圈文創成員
- Onion Design Associates
- Nominated for Best Album Packaging at the 57th Grammy Awards
- Nominated for Best Album Packaging at the 25th and 27th Golden Melody Awards
- Typography Instructor at Xue Xue Institute.
- Member of the Tien Tien Circle Creatives

## 評審介紹 Jury Introduction

### 視覺設計 Visual Design



初審評審  
*Juror of Preliminary Stage*

#### 黃國瑜 Kuo-Yu Huang | 臺灣 Taiwan

- Transform Design 創辦人 / 創意總監
- 2011 創立 Transform Design 瑜悅設計有限公司
- 2006 入圍波蘭華沙國際海報雙年展與墨西哥海報雙年展
- 2016 作品入圍 TDC 企業形象組
- 2017 if Design Awards 品牌形象三項入圍
- Creative Director of Transform Design
- Founded His own studio in Taipei, Taiwan in 2011
- Selected for International Poster Biennale in Warsaw and International Biennale of Poster in Mexico in 2006
- Selected for TDC's Corporate Identity Category in 2016
- The Three Works of transform design is nominated for the Corporate Identity/Branding iF design award 2017



初審評審  
*Juror of Preliminary Stage*

#### 陳進東 James Chen | 臺灣 Taiwan

- 麥傑廣告設計創意總監
- 中華平面設計協會榮譽理事長
- 2017 年冬季亞運局日本札幌海報展評審
- 臺灣外貿發展協會 (TAITRA) 品牌臺灣計畫品牌課程講師
- 景文科技大學視覺傳播設計系兼任助理教授
- Magic Creative Design Creative Director
- Taiwan Graphic Design Association Honorary President
- 2017 Winter Asian Games Sapporo Poster Design Competition
- Taiwan External Trade Development Council (TAITRA) .Branding Taiwan / Lecturer
- JinWen University of Science & Technology the Department of Visual Communication Design / assistant professor



初審評審  
*Juror of Preliminary Stage*

#### 陳重宏 (馬賽 Kyo) Chung-Hung Chen | 臺灣 Taiwan

- 資深設計師
- 具廣告創意人、視覺設計師、插畫工作者、極地攝影師、導演、旅行圖文作者、藝術創作者多種身份
- 唯一同時擁有英國倫敦國際獎、紐約國際廣告獎以及美國莫比斯國際廣告獎三大國際廣告獎 平面插畫類金獎之華人獲獎者
- 曾榮獲法國巴黎 PX3 攝影大賽金獎、莫斯科 MIFA 國際攝影賽金獎、美國 IPA 國際攝影大賽、Leica 萊卡國際攝影賽
- 曾榮獲波蘭華沙海報獎、墨西哥海報獎等，共獲得三百多項平面設計、廣告與攝影類跨領域獎項
- Senior Designer
- Multiple identities as a Creative Free-Lancer, an Illustration Publishing Creator, a Travel Writer, a Video Director, an Artist and a Photographer
- The only Taiwanese won the GOLD Award of illustration category of "London International Awards", "The New York Festivals" and "The Mobius Advertising Awards" at the same time
- GOLD Awards of Professional, PX3 (Prix de la Photographie Paris), GOLD Awards of Professional, MIFA (MOSCOW INTERNATIONAL FOTO AWARDS) , GOLD Award of Professional, IPA (International Photography Awards USA), Leica International Photography Awards
- 2008 International Poster Biennale in Warsaw and 2010 the International Biennale of Poster in Mexico etc., he won over three hundreds of awards such as illustration, advertisement and photography category



初審評審  
*Juror of Preliminary Stage*

張雅婷 **Ya-Ting Chang** | 臺灣 Taiwan

- 2014 至今, 美商 Superior Communications/ puregear 資深設計師
- 2016 獲選臺灣文博會 Talent 100 創作者
- 2014 獲選 7-11 CITY CAFE 曼特寧咖啡探索家
- 2011 獲得德國 IF 傳達設計獎 -The Best of 100
- 2010 獲得墨西哥海報雙年展, 優選
- 2010 參與海外菁英計畫, 獲得公費至英國修習平面碩士課程, 取得 MA Graphic Design 學位
- 2014-present Senior Graphic Designer, Superior Communications / Pure Gear
- 2016, Taiwan Culture Expo Talent 100, "Selection"
- 2014, 7-11 CITY CAFE coffee Explorer, "Final"
- 2011, iF Concept Award, "The Best of 100"
- 2010, 11th International Poster Biennial of Mexico, "Selection"
- 2009, "2010 Taiwan Ministry of Education Scholarship Program for Overseas Study in Arts and Design", Winner



初審評審  
*Juror of Preliminary Stage*

王胤卓 **Draw Wang** | 臺灣 Taiwan

- 大象設計整合有限公司 - 負責人
- 2014 金門縣教師職業工會企業視覺辨識系統設計
- 2015 金門醫院企業視覺辨識系統設計
- 2016 臺灣農畜產工業股份有限公司「呷肉」品牌形象展覽設計
- 2017 客家電視臺「大聲 My 客風」節目視覺形象設計
- 2017 陽明海運集團陽明文化藝術館「TEU」陽明海運全球貨櫃運輸展覽場暨視覺設計
- Elephant Design Integration Co., Ltd. Owner
- 2014 Corporate Identity System Design for Kinmen Teacher's Union
- 2015 Corporate Identity System Design for Kinmen Hospital
- 2016 "Ja Bah" Brand Image Exhibition Design for Taiwan Agricultural and Livestock Industry Co., Ltd.
- 2017 Visual Image Design for Hakka TV Program 《My Loud Mic》
- 2017 Exhibition & Visual Design of "TEU: Yangming Shipping Global Container Transportation Exhibition" by Yangming Maritime Culture & Art Museum"



決審評審  
*Juror of Final Stage*

野老朝雄 **Asao Tokolo** | 日本 Japan

- 東京造形大學室內建築設計系畢業、就讀倫敦建築聯盟學院
- 曾擔任日本建築大師江頭慎助理、東京大學兼任講師、造形大學客座教授、筑波大學兼任講師
- 參展：2010 東京現代藝術博物館年度裝飾展、2014 東京藝術大學美術陳列館物質化二代展、2016 「個人與群體」野老朝雄 × 青森市所 作品展
- 設計作品：東京工學院大學教育紀念廳外牆、名古屋大樓玻璃帷幕圖樣設計、三宅一生圖樣設計、東京 2020 會徽、東京文京市市徽、大手町公園大廈入口裝置藝術等
- B.Des.in Interior Architectural at Tokyo Zokei University, London Architectural Association School of Architectural
- Assistant for EGASHIRA Shin, Part-time Lecturer at Tokyo University, Visiting professor at Tokyo Zokei University, Part-time Lecturer at University of Tsukuba
- Neo-Ornamentalism from Museum of Contemporary Art (2010), Materializing II Chinretsukan Gallery The Art Museum of the Tokyo University of the Arts (2014), TOKOLO Asao × Aomori City Archives Exhibition "Individual and Group" of Aomori Contemporary Art Centre (2016)
- Façade Pattern Design of Kogakuin University 125th Memorial Education Center, Design Dai Nagoya Building Façade glass Pattern Design for the Lower Part, TOKOLO PATTERN for BAO BAO ISSEY MIYAKE, TOKYO 2020 Emblem, Bunkyo City Logo, art Work for the Entrance in Otemachi Park Building etc.



## 評審介紹 Jury Introduction

### 視覺設計 Visual Design



決審評審  
*Juror of Final Stage*

#### **Aram Huerta** | 墨西哥 Mexico

- 身為設計師、文化工作經理、文化推廣人
- 第十四屆墨西哥國際海報雙年展評審
- 研討會主持人並在多處組織分享經驗
- 曾任墨西哥哈拉帕公立大學專屬平面設計師長達二十年
- 超過六十件海報及插畫在國際間展出
- Graphic Artist, Cultural Manager and Promoter
- Jury at the 14th International Poster Biennial in Mexico.
- Workshop Facilitator Sharing Learning Experiences at Diverse Institutions
- Graphic Designer for Universidad Veracruzana for over 20 years
- More than 60 poster and Illustrations Exhibited Internationally



決審評審  
*Juror of Final Stage*

#### **Bang Won Lee** | 韓國 Korea

- 慶星大學視覺傳達設計學系助理教授
- 韓國設計大展指定設計師
- 入圍義大利 Good 50x70 社交計畫
- 入圍義大利 Utilta Manifesta 設計大賽
- 入圍莫斯科 Golden Bee 9 國際平面設計大賽
- 入選厄瓜多爾海報雙年展
- Assistant Professor, Department of Visual Communication Design at Kyungsoong University
- Established Designer at Korea Design Exhibition
- Good 50x70 The Social Communication Project Finalist
- Italy Utilta Manifesta / Design For / Social Finalist
- Russia Golden Bee 9 Moscow International Biennale of Graphic Design Finalist
- Ecuador Poster Biennial Selected



決審評審  
*Juror of Final Stage*

#### **Arnault Garcia** | 法國 France

- 曾任法國設計師聯盟主席，現任法國設計師聯盟副主席
- 上海工藝美術職業學院教授
- 法國設計師聯盟聯合創辦人 (生態設計部門)
- 2014 上海設計周金座獎得主
- 提名巴黎 COP21 Students Programs 講師
- 榮獲法國阿基坦 Sustainable Programs AGENDA 21 獎項
- A.P.C.I. Observateur du Design 大賽評審
- French Alliance of Designers (AFD) President (2009-2011), Current Vice-President (2017-2018)
- Shanghai Art & Design Academy, Professor
- Co-founder of the AFD Charter of Ecodesigners
- Shanghai Design Week Price Winner for Golden Seat (2014)
- Nominated for COP21 Student's Programs in Paris Lecturer in Pavillon France
- Price Winner for Sustainable Programs AGENDA 21, France Aquitaine (2010, 2012, 2015)
- Judge for Observateur du Design, France (2014)

視覺設計 Visual Design



決審評審  
*Juror of Final Stage*

**Ksenya Samarskaya** | 美國 United States of America

- Samarskaya & Partners 創意職人
- 2015-2017 美國平面設計協會成員
- 2017 紐約字體藝術指導俱樂部評審
- 2017 擔任 Communication Arts 評審
- 2011-2012 擔任蘋果文字藝術設計顧問
- Creative Practitioner at Samarskaya & Partners (2013–Present)
- Board Member of AIGA/NY (2015–2017)
- Judge for Type Directors Club (2017)
- Judge for Communication Arts (2017)
- Type Consultant at Apple (2011–2012)



決審評審  
*Juror of Final Stage*

**Pavel Noga** | 捷克 Czech Republic

- 自由平面設計師
- 擔任湯瑪士貝達大學、馬薩里克大學以及布爾諾理工大學副教授
- 著有《Design on the Road》以及《Typographic Poster》
- 負責多項平面設計大展
- Designer – Freelancer / Graphic Design
- Associate Professor at Tomas Bata University Zlin, Masaryk University Brno and Technical University Brno
- Author of 《Design on the Road and Typographic Poster》 and 《Typographic Poster》
- Curator of Graphic Design Exhibitions



決審評審  
*Juror of Final Stage*

**Mehdi Saeedi** | 伊朗 Iran

- 伊朗平面設計師協會成員
- 美國陶森大學兼任教師
- 於多國舉辦講座：紐約字體藝術指導俱樂部、國際平面設計協會、中國、臺灣、日本、法國、伊朗、墨西哥、波利維亞、德國、巴西、科威特、卡達、阿拉伯聯合大公國、土耳其、斯洛維尼亞等
- 榮獲科羅拉多國際海報雙年展首獎、臺灣國際平面設計獎大獎、五星設計師宴 - 大阪國際海報三年展大獎、五星設計師宴 - 大阪國際海報三年展大獎、斯洛伐克國際海報三年展一等獎、美國 Graphis 大賽金獎等
- Member of IGDS
- Part-Time Faculty at Towson University in Maryland, the USA.
- Held Lectures: Type Director Club in NYC, US Library of Congress of United State Icoagrada, China, and Others Countries such as Taiwan, Japan, France, Iran, Mexico, Bolivia, Germany, Brazil, Kuwait, Qatar, UAE, Turkey, Slovenia, etc.
- Awarded by Colorado International Invitational Poster, Taiwan International Poster Design Award, Five Stars Designers Banquet International Invitational Poster Triennial Osaka, Ekoplakat'11 International Posters Triennial, Graphis Award etc.

## 評審介紹 Jury Introduction

數位動畫 Digital Animation



召集人  
*The Convener of Judging Panel*

紀柏舟 **Pochou Chi** | 臺灣 Taiwan

- 動畫導演與藝術總監，作品「回憶抽屜」、「光之塔」、「急救時刻」、「暖冬」、「春雨」等等，獲得超過 40 項國際獎項與 100 項國際影展肯定
- 美國好萊塢分鏡藝術家，合作於 Marvel、DreamWork
- 品牌廣告導演與多家企業藝術總監，客戶遍布臺灣、上海、芝加哥
- 光之塔動畫事業之導演暨負責人
- 2017 臺北電影節動畫評審召集人
- 2016 金馬獎頒獎典禮視覺藝術總監
- Independent Animation Director, Winning over 40 International Awards
- Story Artist in Los Angeles
- Commercial Live-action Director and Art Director, Cooperating with Global Enterprises from Chicago, Los Angeles, and Taipei
- Chairman and Director at the Mangowork Studio
- 2017 Jury at the 19th Taipei Film Festival
- 2016 Visual Art Director at the 53th Golden Horse Awards



初 / 決選評審  
*Juror of Preliminary / Final Stage*

劉綺珊 **Chishan Liu** | 臺灣 Taiwan

- 免將創意影業 影片部製作總監
- 曾參與《阿凡達》、《猩球崛起》、《天使與魔鬼》、《黃金羅盤》、《雙鼠記》、《快樂腳》，擔任數位燈光技術師
- 帶領團隊製作的作品有《KANO》、《想飛》、《捉妖記》部分的電影特效，以及多部得獎原創動畫短片
- 2016 年以《紅衣小女孩》入圍金馬獎《最佳視覺效果獎》
- Production Supervisor of The White Rabbit Entertainment, Inc.
- Lighting Technical Director of 《Afanda》, 《Rise of the Planet of the Apes》, 《Angels & Demons》, 《The Golden Compass》, 《The Tale of Despereaux》 and 《Happy Feet》
- Led the Team of 《KANO》, 《Dream Flight》, 《Monster Hunt》 and Various Award-Wining Original Animation Short Films
- 《The Tag-Along》 was selected for 2016 Golden Horse Award for Best Visual Effects



初審評審  
*Juror of Preliminary Stage*

Punlarp Punnotok | 泰國 Thailand

- 泰國平面設計協會 (Thaiga) 的共同創辦人
- 先皇技術學院之批判性碩士學位學程之特聘專業人士
- 於宋卡王子大學北大年校區之批判性學士學位學程擔任特聘專家，在傳播科學學院的創新課程中的媒體設計及創意課程中教學
- 於非政府組織目甲訕創意公園組織擔任負責人暨總監
- Color Party Object 有限公司及 Palette 設計工作室有限公司之創辦人暨總監
- Co-Founder of Thaiga (Thailand Graphic Design Association)
- Special Expert for Critical Master Degree Program for King Mongkut Institute of Technology Ladkrabang
- Special Expert for Critical Bachelor Degree Program for Innovative Course in Media Design and Creativity Faculty of Communication Sciences Prince of Songkla University Pattani Campus
- Head & Principle of The Network of Makkasan Creative Park Campaign (Non-Government Organization)
- Co-Founder & Principle of Color Party Object Co., Ltd. And Palette Design Studio Co., Ltd.





初審評審  
*Juror of Preliminary Stage*

邱禹鳳 **Yu-Feng Chiu** | 臺灣 Taiwan

- 2016 金馬獎 動畫初審
- 2013 臺北金馬國際影展「我們都是蒙娜麗莎」入選
- 2010 莫斯科媒體藝術暨當代動畫影展競賽單元「呢喃」入選
- 2006 紐約女性影展「時光」獲入選
- 2002 臺北電影節動畫競賽類「旅」獲 最佳導演獎
- 2001 臺北電影節 動畫競賽類「時光」獲 最佳動畫 首獎
- Judge of 2016 Golden Horse Award for Best Animation Feature
- 2013 The Golden Horse Taipei International Film Festival Selected
- 2010 Moscow 《LINOLEUM》 International Fest of Contemporary Animation and Media-Art selected the main Competition Program
- 2006 New York / Taiwan Women Film Festival Selected
- 2002 《Travel》 Sand Animation 「The Best Animation Director Award」 in 4th Taipei Film Festival
- 2001 《Time》 Sand Animation 「The Best Animation Award」 in 3rd Taipei Film Festival



初審評審  
*Juror of Preliminary Stage*

陳怡菁 **Yi-Ching Chen** | 臺灣 Taiwan

- 策展十多年經驗，曾在中國，加拿大，法國等國策劃影展及動畫節目
- 第一屆，第二屆臺中國際動畫影展策展人
- 2016 金馬獎動畫類評審
- 文化部輔導金動畫短片「金魚」製片
- 零壹影像有限公司負責人
- Over 10 Years Experience in Festival Programming, Working in China, Canada and France
- Artistic Director of the First and Second Editions of the Taichung International Animation Festival, (TIAF)
- Jury Member in the Animation Category of 2016 Golden Horse Awards
- Producer of "Golden Fish", an Animation Short Funded by Minster of Culture
- Managing director of Zero One Film Co.



初審評審  
*Juror of Preliminary Stage*

連俊傑 **Chun-Chien Lien** | 臺灣 Taiwan

- 1994 紐約普瑞特藝術學院傳播設計碩士畢業
- 2004 至今，連想創意負責人 / 創意總監
- 2000-2004 洛杉磯 Imaginary Forces 資深設計 / 導演 / 動畫
- 2010 動畫短片“Reboot” 入圍倫敦 Onedotzero-Adventures in Motion International Festival
- 第 74 屆奧斯卡金像獎頒獎典禮影像作品“Salute to Film Composers” 獲 Outstanding example of design communications in 365: AIGA Year in Design 2003
- Master of Science, Communications Design Department, Pratt Institute, August 1991- May 1994
- dottodot inc., Funder / Creative Director (2004-present)
- Imaginary Forces LA, Senior Designer / Director / Animator (June 2000 - 2004)
- Show included, Short film "Reboot", London Onedotzero-Adventures in Motion International Festival, 2010
- Outstanding Example of Design Communications in 365: AIGA Year in Design 2003, "Salute to Film Composers"

## 評審介紹 Jury Introduction

數位動畫 Digital Animation



決審評審  
Juror of Final Stage

劉華智 **Mann Lao** | 澳門 Macau

- Chiii Design 創始人 / 創意總監
- YSHOW 創始人，2016 策劃澳門首屆 YSHOW 畢業設計作品聯展
- Chiii Design 的設計作品不但經常獲邀到世界各地展出，更分別在十多個不同國家及地區獲得超過 200 個重要獎項，包括墨西哥國際海報雙年展、玻利維亞國際海報雙年展、法國肖蒙國際海報節、俄羅斯金蜜蜂國設計雙年展、澳門設計雙年展等
- Founder & Creative Director of Chiii Design
- Founder of YSHOW. Bringing out the First Macau Art Graduates Joint Y Show Exhibition
- Chiii Design have exhibited their works in over 10 countries/regions, and have won more than 200 awards. Including the International Poster Biennial in Mexico; the Biennial of Poster Bolivia; the International Poster and Graphic Design Festival in Chaumont of France; Golden Bee—Moscow and Macau Design Biennial etc.



決審評審  
Juror of Final Stage

Mike Howie | 紐西蘭 New Zealand

- Flux 動畫工作室 - 資深藝術總監 / 資深動畫師 / 導演
- 紐西蘭 Best Awards 上獲得多項金獎肯定
- 澳洲迪士尼動畫工作室資深動畫師
- 倫敦 Espresso Animation 首席動畫師
- 柏林 Hahn Film 分鏡師
- 業界超過二十五年以上經驗
- Flux Animation - Senior Art Director / Senior Animator / Director
- Best Design Award Winner
- Worked for Walt Disney Animation Studios Australia as Senior Animator
- Worked for Espresso Animation, London, as Lead Animator
- Worked for Hahn Film, Berlin, as Storyboard Artist
- Over 25 Years Experience



決審評審  
Juror of Final Stage

高少康 **Hong Ko** | 香港 Hong Kong

- 香港著名設計師，斬劉高設計合夥人。
- 香港設計師協會會員
- 廣州美術學院客座教授
- 2011 獲「藝術與設計」雜誌選為年度人物，2014 獲透視 40 驕子獎「Perspective: 40 under 40」、香港十大傑出設計師獎，為中國與香港新一代設計界的代表人物
- 品牌設計經驗豐富，獲獎無數，主導過不少具影響力的項目，其中包括：深圳機場集團、八馬茶業、五谷磨房與獐子島等品牌整合升級
- A Leading Designer, the Partner and the Creative Director of KL&K Design
- Committee Member of Hong Kong Designer Association
- Held Lecturer: The Guangzhou Academy of Fine Arts
- Awarded by the 《People of the Year》 by Magazine Art & Design (2011), 40 under 40 by Perspective Magazine (2014), Ten Outstanding Designers Awards (2014), which has proved him as one of the leading young creative figures of China
- Vast experience in branding design and has won numerous awards. Influential branding projects include: Shenzhen Airport Group, Bama Tea, Wugumf and Zoneco, etc.



決審評審  
*Juror of Final Stage*

**周思穎 Beatrix Chow** | 香港 Hong Kong

- Vision Desire 共同創辦人，這是一間著重使用者經驗、互動式設計、多媒體及品牌設計的獨立廣告公司
- 2017 年榮獲 A' 設計獎手機技術大獎，2015 年間獲得四項國際大獎，包括金點設計獎及亞洲設計大獎
- 畢業於香港城市大學數位及視覺設計學系
- 深信橫跨媒體及設計界的以人為本之設計，目的是為了解決人們的問題
- 熱愛美容及數位產業，鼓勵所有女性勇敢做自己
- Co-Founded Vision Desire, a Boutique Agency Specialized in UX, Interactive Design, Multimedia and Branding
- Award Winner of A' Design Award Category for Mobile Technologies (2017), Received 4 International Accolades, Including the Golden Pin and Design Award Asia (2015)
- Graduated at City University of Hong Kong, Digital of Visual Design
- Believe in human centered design across all media / Design is to provide solution for human
- A Beauty & Digital Enthusiast, encouraging women to be bold and feel comfortable in her own skin



決審評審  
*Juror of Final Stage*

**Nat Yoswatananont** | 泰國 Thailand

- Igloo Studio 創辦人、創意總監
- 動畫片《Nine Satra》導演兼編劇
- 系列動畫《The Salads》導演兼編劇
- 榮獲第十屆 Digicon6 地區大獎、2009 SICAF 入選決賽
- 泰國朱拉隆功大學建築學士
- Founder and Creative Director at Igloo Studio, Thailand
- Director and Screenwriter, 《Nine Satra》 Animated Feature Film
- Director and Screenwriter, 《The Salads》 Animated Series
- Winner of Digicon6 #10 Regional Award, Finalist of SICAF (2009)
- Chulalongkorn University, Bachelor of Architecture



決審評審  
*Juror of Final Stage*

**Su Eing Chee** | 新加坡 Singapore

- 新加坡設計業總商會副主席
- 新加坡企業集團 D'Perception 私人有限公司董事會成員
- D'Perception Ritz 私人有限公司董事
- D'Perception 印尼分公司總經理
- 觀光與住宿專案獎項：
  - 2013 年 BCI Asia Awards
  - 2013 年及 2016 年 SDA 大獎
  - 2014 年、2015 年及 2017 年新加坡優良設計標誌獎
- Vice-President, Design Business Chamber Singapore
- Board of Directors, D'Perception Pte Ltd (Group of Companies)
- Principal, D'Perception Ritz Pte Ltd
- President, D'Perception Indonesia Pte Ltd
- Hospitality and Resident Projects Awards:
  - BEI Asia Award 2013
  - SDA 2013, 2016
  - SG Mark 2014, 2015, 2017





決審評審  
*Juror of Final Stage*

**Zachary Haris Ong** | 馬來西亞 Malaysia

- 國際設計社團協會會長
- 2011 年提名吉隆坡設計週終身成就獎
- 2012 國際設計社團協會砂拉越設計週專案經理
- WREGA 馬來西亞平面設計協會總監
- 獲頒四十位 40 歲以下馬來西亞最具影響人物獎
  
- International Council of Design President
- Nominated for the Prestigious 7 Bintang Lifetime Achievement Award at Kuala Lumpur Design Week
- Project Manager for Rediscovery: Icoграда Design Week in Sarawak
- Former President of WREGA, the Graphic Design Association of Malaysia
- Awarded by Prestige Magazine in the Top 40 Movers and Shakers in Malaysia under 40



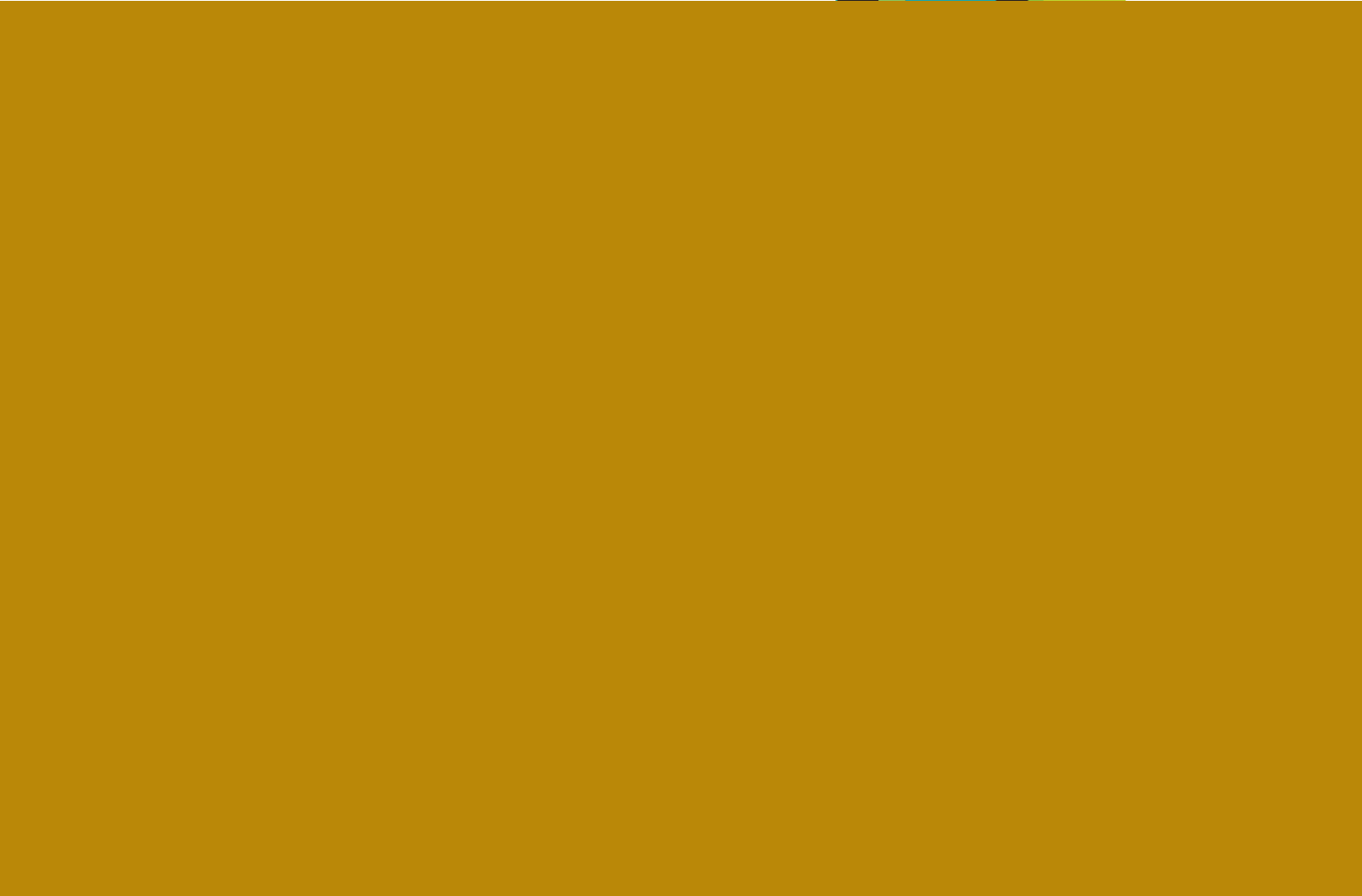





2017

# Opportunity

---

活動紀實

On the Spot

## 初選紀實 Preliminary Selection

2017年9月2-4日「2017臺灣國際學生創意設計大賽」初選於臺北市長官邸藝文沙龍盛大展開。本次初選邀請來自「產品設計」、「視覺設計」及「數位動畫」專門領域的22位臺灣業界和國際級專家擔任三類組初選評審。而廠商指定類評選則由產品設計類之評審審查來自世界各國學生的創意作品。今年收件數量再創新高，非臺灣學生的作品參賽數量也再次超越臺灣學生，作品來源也較往年更加多元與精采。本年度四類別之收件總數高達18,932件，較去年收件數成長近4000件。經過三天的嚴格評選與熱烈討論，最終評選出產品設計類109件、視覺設計類226件、數位動畫類39件、廠商指定類49件，共423件優秀作品進入決選。

The preliminary selection of 2017 Taiwan International Student Design Competition officially started at the Mayor's Residence Art Salon on 2nd to 4th September 2017. The preliminary selection invited 22 domestic and international experts from the specialized areas of "Product Design," "Visual Design" and "Digital Animation" as the panel of judges for the three categories of the Competition. As for the Brand Specified category, the design works from students around the world were evaluated by the judges of the Product Design category. This year, the number of received entries reached a new high yet again, and the number of non-Taiwanese students' entries once again exceeded that of Taiwanese students' entries. The sources of works were much more diverse than in the previous years as well. The total number of received entries for the four categories this year was 18,932, which represents a growth by nearly 4,000 pieces from last year. After three days of strict and enthusiastic judging and discussion, 109 pieces of the Product Design category, 226 pieces of the Visual Design category, 39 pieces of the Digital Animation category, and 49 pieces of the Brand Specified category were finally selected. A total of 423 outstanding entries were nominated into the final selection.



初選開幕 The Opening of Preliminary Selection



計畫主持人林磐聳致詞與競賽介紹與說明  
Address by Project Director Apex Lin and Introduced the Competition



贊助廠商《看見台灣基金會》執行長陳文堂先生致詞  
Address by Mr. Don Chen, CEO of iSee Taiwan Foundation





初選評審與執行小組代表合影 Picture of the Preliminary Evaluation Accreditation Team and Executive's Representatives



贊助單位代表、初選評審與執行小組代表合影  
Picture of Sponsor's Representatives, the Jury of Preliminary Selection and Executive's Representatives



初選開幕 The Opening of Preliminary Selection

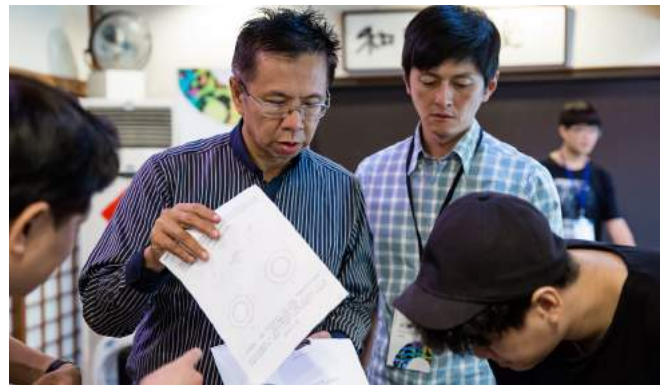
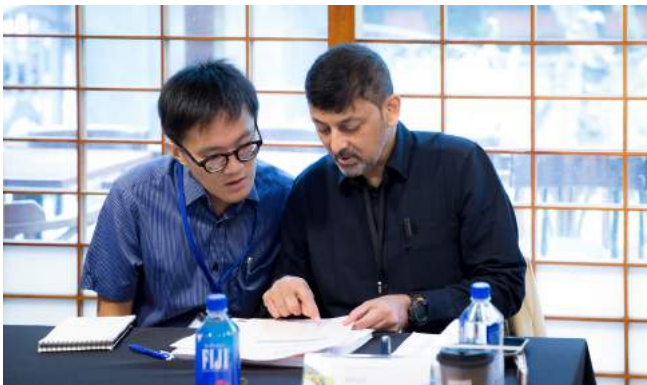

初選：產品設計類評審狀況 Preliminary Selection: Jury of Product Design Category



## 初選紀實 Preliminary Selection



初選：視覺設計類評審狀況 Preliminary Selection: Jury of Visual Design Category







初選：廠商指定類評審狀況 Preliminary Selection: Jury of Brand Specified Category





## 決選紀實 Final Selection

「2017 臺灣國際學生設計大賽」從 2008 年耕耘至今，已邁入第十個年頭，今年競賽以「Opportunity」為主題，期望學生面對挑戰、選擇機會、整合資源、創造價值，終透過設計體現，傳達 Opportunity 的概念。

競賽分為產品設計、視覺設計、數位動畫及廠商指定四類別，獎項共有年度大獎 1 名、各類組金獎 1 名、銀獎 1 名、銅獎 3 名，以及佳作共 22 名。由教育部青年發展署和《財團法人溫世仁文教基金會》共同贊助國際設計組織特別獎 16 名（包括 Alliance Francaise des designers〔法國設計師聯盟〕、Brno Biennale Association〔捷克布魯諾雙年展協會〕、Design Business Chamber Singapore〔新加坡設計業總商會〕、Good Design Australia〔澳大利亞優良設計協會〕、German Design Council〔德國國家設計委員會〕、Hong Kong Federation of Design Associations〔香港設計總會〕、International Council of Design〔國際設計社團協會〕、India Design Council〔印度設計委員會〕、International Poster Biennial in Mexico〔墨西哥國際海報雙年展協會〕、Japan Institute of Design Promotion〔日本設計振興會〕、Korea Ensemble of Contemporary Design〔韓國現代設計協會〕、Macau Designers Association〔澳門設計師協會〕、Thailand Creative & Design Center〔泰國創意設計中心〕、The Design Alliance Asia (tDA Asia)〔亞洲設計連〕、Taiwan Design Center〔台灣創意設計中

心〕和 The Designers Institute of New Zealand〔紐西蘭設計師協會〕）

由《財團法人看見台灣基金會》贊助廠商指定類主題為「新食器時代－臺灣茶具設計」，期許學生在製作的過程中能更認識臺灣特有文化，共評選出金獎 1 名、銀獎 2 名、銅獎 4 名及佳作 7 名，期待獲獎的精采作品能讓世界看見臺灣之美。

決選評審們普遍認為今年的入圍作品能從眾多參賽作品中脫穎而出，是因為作品具有高水平且風格多元、作品也相當國際化。根據執行小組統計，今年總共有來自 71 個國家地區，18,932 件作品參賽，日前由來自國內外 27 位不同設計領域的專家評審，經過熱烈討論，最終從 423 件入圍作品中，選出了 68 件得獎作品。最大獎項的年度大獎得主，將可獲頒新臺幣 40 萬元獎金。



計畫主持人林磐聳致詞與競賽介紹與說明

Address by Project Director Apex Lin and Introduced the Competition



Since 2008, "2017 Taiwan International Student Design Competition" has entered its 10th year. The theme of this year's competition is "Opportunity." We encourage participants to take on challenges, embrace opportunities, harmonize resources and create value. Through unique design and implementation in light to best convey the concept of Opportunity.

The competition is divided into four groups, namely Product Design, Visual Design, Digital Animation, and Brand Specified Category. Awards include one Grand Prix and awards for each of the categories (excluding Brand Specified Category), namely one Gold and Silver Prize for each group, three Bronze Prizes and 22 Honorable mentioned awards. Sponsored by Youth Development Administration, Ministry of Education and Sayling Wen Cultural & Educational Foundation, there are 16 Special prizes endorsed by international design associations. Including Alliance Francaise des designers, Brno Biennale Association, Design Business Chamber Singapore, Good Design Australia, German Design Council, Hong Kong Federation of Design Associations, International Council of Design, India Design Council, International Poster Biennial in Mexico, Japan Institute of Design Promotion, Korea Ensemble of Contemporary Design, Macau Designers Association, Thailand Creative & Design Center, Design Alliance Asia (tDA Asia), Taiwan Design Center and The Designers Institute of New Zealand.

Sponsored by iSee Taiwan Foundation, the theme for the brand specified category is "Taiwan Teaware Design". To signify the uniqueness of Taiwanese teaware culture, students are anticipated

to generate innovative ideas for Taiwanese teaware. For this category, TISDC selected 1 Gold Prize, 2 Silver Prize, 4 Bronze Prize and 7 Honorable Mention Prize. We sincerely hope the world can see the beauty of Taiwan through the Winning works.

The judge panel of the final selection generally agreed that the quality standard of this year's finalists was quite high and internationalized. Many works were inspired from current issues in the society; the works were very thought provoking. According to the statistics done by the executive team, a total of 18,932 pieces of work came from 71 countries or regions. After the fervent discussion among 27 domestic and foreign professional judges of panel from different specialized design disciplines, 423 pieces of work were selected as the winning works out of 68 pieces of nominated works. The winner of the biggest prize of the year will be awarded a prize of NT\$ 400,000.



決選評審、國際設計組織代表與執行小組代表合影

Picture of the Final Evaluation Accreditation Team, International Design Association Delegates and Executive's Representatives

## 決選紀實 Final Selection



決選：產品設計類評審狀況 Final Selection in Product Design Category







決選：數位動畫類評審狀況 Final Selection in Digital Animation Category



決選：廠商指定類評審狀況 Final Selection in Brand Specified Category



## 2017 臺灣國際學生創意設計大賽收件結果 2017 TISDC Entries Statics

洲別 Continent	國家或地區 Country or Region	報名數 Registration Entries	符合資格件數 Qualified Entries	產品設計類 Product Design Category	視覺設計類 Visual Design Category	數位動畫類 Digital Animation Category	廠商指定類 Brand Specified Category	入圍作品總件數 Number of Finalists	得獎總件數 Number of Winners					
亞洲 Asia	中國大陸 China	1	10252	9206	2831	44	5912	104	280	15	183	20	183	19
	臺灣 Taiwan	2	6966	5912	855	25	4506	61	135	13	416	21	120	31
	印度 India	3	243	149	99	8	44	4	4	0	2	0	12	1
	韓國 Korea	4	199	169	39	8	129	4	0	0	1	0	12	1
	馬來西亞 Malaysia	5	191	142	27	1	94	8	4	0	17	3	12	1
	新加坡 Singapore	6	105	84	19	3	55	8	6	0	4	0	11	2
	越南 Vietnam	7	95	85	8	0	71	1	4	0	2	1	2	0
	香港 Hong Kong	8	65	49	14	1	35	1	0	0	0	0	2	0
	印尼 Indonesia	9	53	31	6	0	24	2	0	0	1	0	2	0
	澳門 Macau	10	49	39	5	0	32	2	0	0	2	2	4	0
	寮國 Lao	11	47	42	1	0	40	2	1	0	0	0	2	0
	菲律賓 Republic of the Philippines	12	42	36	0	0	36	1	0	0	0	0	1	0
	日本 Japan	13	37	23	5	0	17	1	1	1	0	0	2	1
	伊朗 Iran	14	32	30	9	0	21	1	0	0	0	0	1	0
	泰國 Thailand	15	24	21	7	0	3	0	2	1	9	0	1	0
	斯里蘭卡 Sri Lanka	16	8	6	3	1	3	0	0	0	0	0	1	0
	土耳其 Turkey	17	5	3	2	0	1	0	0	0	0	0	0	0
	黎巴嫩 Republic of Lebanon	18	2	2	1	0	1	0	0	0	0	0	0	0
	尼泊爾 Nepal	19	2	2	2	0	0	0	0	0	0	0	0	0
	巴勒斯坦領土 Palestinian territory	20	2	0	0	0	0	0	0	0	0	0	0	0
	緬甸 Republic of the Union of Myanmar	21	1	1	0	0	1	0	0	0	0	0	0	0
	約旦 Jordan	22	1	0	0	0	0	0	0	0	0	0	0	0
	敘利亞 Syrian Arab Republic	23	1	0	0	0	0	0	0	0	0	0	0	0
	烏茲別克斯坦 Uzbekistan	24	1	0	0	0	0	0	0	0	0	0	0	0
歐洲 Europe	德國 Germany	25	53	41	25	5	11	2	3	0	2	2	9	0
	俄羅斯 Russia	26	26	20	10	1	8	5	2	0	0	0	6	1
	白俄羅斯 Belarus	27	23	21	18	1	3	0	0	0	0	0	1	0
	英國 United Kingdom	28	20	15	8	4	7	0	0	0	0	0	4	1
	捷克共和國 Czech Republic	29	16	13	6	0	7	0	0	0	0	0	0	0
	義大利 Italy	30	13	12	0	0	12	3	0	0	0	0	3	0
	法國 French	31	12	11	6	1	5	0	0	0	0	0	1	0
	波蘭 Poland	32	8	8	4	0	4	1	0	0	0	0	1	0
	喬治亞 Sakartvelo	33	6	1	1	1	0	0	0	0	0	0	1	0
	比利時 Belgium	34	6	4	1	0	3	0	0	0	0	0	0	0
	葡萄牙 Portugal	35	5	4	1	0	1	0	2	0	0	0	0	0
	希臘 Greece	36	4	4	0	0	4	0	0	0	0	0	0	0
	阿拉伯聯合大公國 United Arab Emirates	37	4	1	0	0	1	1	0	0	0	0	1	0
	斯洛伐克 Slovakia	38	4	4	0	0	4	1	0	0	0	0	1	0
	西班牙 Spain	39	3	2	0	0	2	0	0	0	0	0	0	0
	立陶宛 Lithuania	40	3	2	1	0	1	0	0	0	0	0	0	0
	烏克蘭 Ukraine	41	2	2	2	0	0	0	0	0	0	0	0	0
	瑞典 Sweden	42	2	1	1	1	0	0	0	0	0	0	1	1
	荷蘭 Netherlands	43	2	2	1	0	1	0	0	0	0	0	0	0
	丹麥 Denmark	44	2	1	1	0	0	0	0	0	0	0	0	0
	愛沙尼亞 Republic of Estonia	45	1	1	0	0	1	0	0	0	0	0	0	0
	挪威 Norway	46	1	1	0	0	1	1	0	0	0	0	1	0
	拉脫維亞 Latvia	47	1	1	1	0	0	0	0	0	0	0	0	0
	愛爾蘭 Republic of Ireland	48	1	1	1	0	0	0	0	0	0	0	0	0
阿曼 Sultanate of Oman	49	1	0	0	0	0	0	0	0	0	0	0	0	
保加利亞 Bulgaria	50	1	0	0	0	0	0	0	0	0	0	0	0	
塞普勒斯 Cyprus	51	1	0	0	0	0	0	0	0	0	0	0	0	
瑞士 Switzerland	52	1	1	1	1	0	0	0	0	0	0	1	1	
奧地利 Austria	53	1	0	0	0	0	0	0	0	0	0	0	0	
美洲 America	美國 United States	54	156	129	14	1	83	9	24	8	8	0	18	7
	薩爾瓦多 El Salvador	55	56	48	3	1	1	1	44	1	0	0	3	0
	加拿大 Canada	56	17	12	1	0	10	1	1	0	0	0	1	0
	墨西哥 Mexico	57	6	5	0	0	5	0	0	0	0	0	0	0
	巴西 Brazil	58	1	0	0	0	0	0	0	0	0	0	0	0
	哥倫比亞 Colombia	59	1	1	0	0	1	0	0	0	0	0	0	0
	厄瓜多 Ecuador	60	1	1	0	0	1	0	0	0	0	0	0	0
	阿根廷 Argentina	61	1	1	0	0	1	0	0	0	0	0	0	0
	宏都拉斯 Honduras	62	1	1	0	0	1	0	0	0	0	0	0	0
	玻利維亞 Bolivia	63	1	0	0	0	0	0	0	0	0	0	0	0
	祕魯 Peru	64	1	0	0	0	0	0	0	0	0	0	0	0
大洋洲 Oceania	澳洲 Australia	65	23	16	4	1	12	1	0	0	0	0	2	1
	聖誕島 Christmas Island	66	2	0	0	0	0	0	0	0	0	0	0	0
	紐西蘭 New Zealand	67	1	1	0	0	1	0	0	0	0	0	0	0
非洲 Africa	南非 South Africa	68	10	9	0	0	8	0	1	0	0	0	0	0
	辛巴威 Zimbabwe	69	4	3	0	0	3	0	0	0	0	0	0	0
	埃及 Egypt	70	3	2	1	0	1	0	0	0	0	0	0	0
	模里西斯 Republic of Mauritius	71	1	0	0	0	0	0	0	0	0	0	0	0
參賽作品總數 Number of Participating Works			18932	16435	4045	109	11229	226	514	39	647	49	423	
參與國家總數 Number of Registered Countries			71	58	41	19	50	25	16	6	12	6	33	總計 Total 68
參賽院校系所總數 Number of Schools & Departments			910	817	393	66	613	117	116	23	105	28	193	

## 歷屆報名收件數 Entries Statistics Over the Years

年度 Year	2008	2009	2010	2011	2012	2013	2014	2015	2016	2017
主題 Theme	出入 In/Out	復甦 Restore	根 Fundamental	NEXT	轉化 Transform	聽見 Sights & Sounds	生生 Circles of Life	擁抱 Embrace	OPEN	Opportunity
參賽總件數 Total Quantity	662	2459	3498	3954	3421	3890	4073	7985	14864	18932
參賽學校系所數 Total School Department	83	130	249	369	516	553	721	790	882	910
報名國家地區數 Total Country / Region	12	19	24	31	35	37	43	46	69	71

年份	臺灣 (Taiwan)	國外 (Overseas)
2008	84%	16%
2009	82%	18%
2010	73%	27%
2011	71%	29%
2012	68%	32%
2013	56%	44%
2014	47%	53%
2015	42%	58%
2016	39%	61%
2017	37%	63%

類別	2008	2009	2010	2011	2012	2013	2014	2015	2016	2017
臺灣件數	559	2038	2545	2815	2315	2179	1930	3360	5726	6966
國外件數	103	421	953	1139	1106	1711	2143	4625	9138	11966

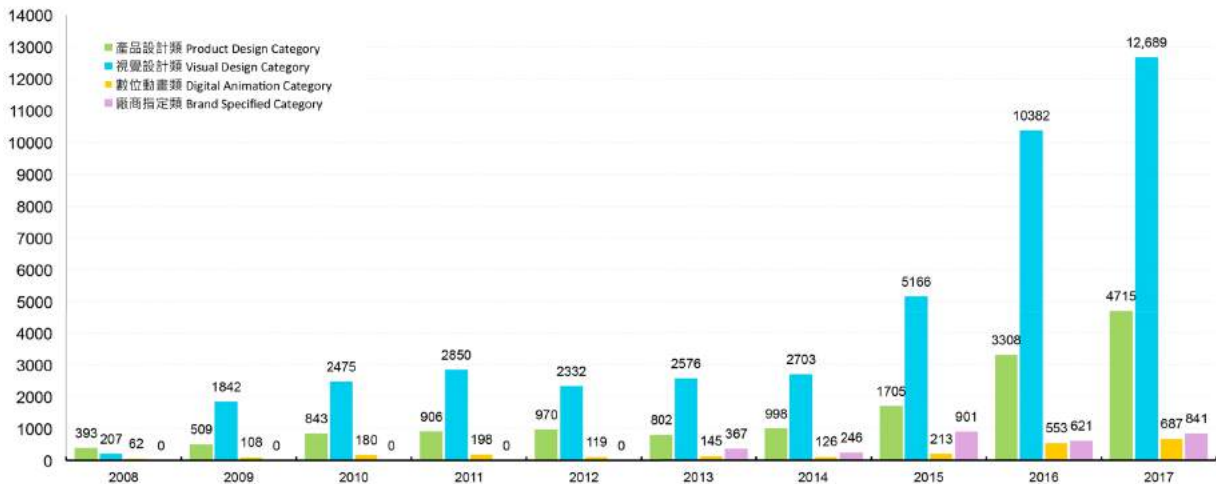

## 四類別收件分析 Analysis of Entries in Four Categories

類別 Category	符合參賽資格作品數量 Number of Entries	決選入圍數量 Number of Finalists	決選入圍率 Percentage of Finalists	得獎作品數量 Number of Winners	得獎率 Percentage of Winners
產品設計 Product Design Category	4045	109	2.7%	18	0.4%
視覺設計 Visual Design Category	11229	226	2.0%	17	0.2%
數位動畫 Digital Animation Category	514	39	7.6%	19	3.7%
廠商指定-「新食器時代 - 臺灣茶具設計」 Brand Specified Category-iSee Taiwan Foundation- New Tableware Era – Taiwan Cuisine Cutlery Design	647	49	7.6%	14	2.2%
<b>合計 Total</b>	<b>16435</b>	<b>423</b>	<b>2.6%</b>	<b>68</b>	<b>0.4%</b>

## 設計講座 Design Seminar

在國際評審訪臺期間，主辦單位舉辦了「國際設計大師系列講座」，邀請設計名家分享對設計的體會與觀察，不僅促進國際交流，更讓喜愛設計的民眾與學子一飽耳福。於臺大醫院國際會議中心、臺中文化創意產業園區以及高雄市立美術館…等，共 6 場演講，總計吸引了超過 1,500 人前來聆聽。講座主題從設計與商業的結合、創意的發想與演繹、到設計工作者與當代社會的關係，提供了不同設計領域各種面向的觀察與思考，場場精采，現場聽眾也熱情回應，把握機會與國際大師們交流。

During the visits of the international judges, the organizer held the "International Design Masters Lecture Series," in which these design experts shared their experience and observations on design. This event not only promoted international exchange but also benefited the public and students who are passionate about design. The six lectures were held at the NTUH International Convention Center, Taichung Cultural and Creative Industries Park, and Kaohsiung Museum of Fine Arts, etc. A total of more than 1,500 people were attracted to the events. The lecture topics ranged from the combination of design and business, inspiration of creativity and creative interpretation, to the relationship between design professionals and the modern society. The lectures provided different design disciplines with various aspects of observation and thinking in different design areas. Every session was remarkable and insightful, and the audience all responded with enthusiasm, taking the opportunity to interact with the international masters.



國際設計大師系列講座：臺北場－臺大醫院國際會議中心  
International Design Masters Lectures Series: Taipei - NTUH International Convention Center



## 臺北 Taipei

臺北場於臺大醫院國際會議中心舉辦，由日本 2020 年東京奧運會 Logo 設計師野老朝雄開場，其主題主要分享個人設計創作的心得、體會與觀察，並進一步討論根據他個人的「個與群」中心思想理論所延伸出的許多跨界合作案例。擔任韓國國民大學設計與工藝研究所院長的鄭道成，則暢談自身的設計哲學，當設計力成為品牌競爭的差異化關鍵時，鼓勵同學們做出賺錢的「有效設計」，讓設計幫忙客戶解決問題、開創新市場。最後則由來自香港的知名靳劉高設計合夥人 Hong Ko 為壓軸，分享關於品牌心動力的設計經驗。從設計塑形到打造品牌，運用自身成功的品牌故事做為引例，展現品牌設計發展各個面向、脈絡及行銷模式，在視覺上及故事上都十分精彩。其講座不僅讓臺灣的學子們有機會與大師們面對面，在當代設計理論及實務應用上獲得許多錦囊妙計，實屬難能可貴的經驗。

The Taipei session was held at NTUH International Convention Center. The first speaker was Asao Tokolo, the logo designer of the 2020 Tokyo Olympics in Japan. He mainly shared his personal stories about design and creation, and he also discussed many cross-disciplinary collaboration cases extended from his own central philosophy of the "Individual vs. Group" theory. Do Sung Chung was Head of Graduate School of Design & Craft Education and Techno Design at Kookmin University, South Korea; he, in turn, talked about his own design philosophy. As design strengths have become the key to differentiation in brand competition nowadays, Chung encouraged students to create "effective design" that is profitable and allow design to help clients solve their problems and open up new markets. The last speaker was Hong Ko, partner at the renowned KL&K Design in Hong Kong. Ko shared his experience on design that appeals to heart. From the design of shapes to brand building, Ko used his own successful brand stories as examples, showing different aspects, contexts and marketing models of brand design and development, all of which was insightful both visually and content-wise. This session allowed students in Taiwan to interact with the international masters in a face-to-face manner and provided them with many tips in terms of the theories and practice of contemporary design. What a precious occasion!



## 設計講座 Design Seminar

### 臺中 Taichung

臺中場於臺中文化創意產業園區舉辦，由 JDP 代表 Shiro Aoki 開場，講述及分享設計概念來源，題材淺顯易懂，敘述方式深入淺出，讓學生輕鬆了解設計的根本；紐約 Samarskaya & Partners 創意職人 Ksenya，以字體設計為演講題材，強調的是字體傳達的意象及身分的串聯，作品豐富感動，讓聽者突破以往對字體及身分的思考，獲益良多。韓國慶星大學視覺傳達設計學系助理教授 Bang won Lee，則以多面向討論視覺繁複性的編排及過程，講述方式十分幽默生動，並與觀眾互動，帶領聽眾進入屬於視覺衝擊的設計領域。最後登場的來自紐西蘭 Mike Howie，闡述自身的動畫人生，分享如何成為一位動畫師，以及自身體驗與設計職場相輔相成的關係。四場演講，場場精采，現場聽眾獲益良多。

The Taichung session was held in the Taichung Cultural and Creative Industries Park. The JDP delegate, Shiro Aoki, was the first speaker, who talked about the sources of his design concepts. The topic was simple, and the language was easy to follow, allowing the students to easily understand the essence of design. Ksenya Samarskaya, creative practitioner at Samarskaya & Partners, took typography as her topic, highlighting the imagery and identity that typography can convey. The works she showed were rich and touching, which broke through the listeners' existing ideas about typography and identity. Bang Won Lee was assistant professor from the Department of Visual Communication Design at Kyung Sung University, South Korea. He discussed the arrangement process of visual complexity from multiple perspectives. His presentation was humorous and vivid in an interactive way, bringing the audience into the design area of visual impact. The last speaker was Mike Howie from New Zealand. He described his life of animation, how he had become an animator, and the complementary relationship between personal experience and design career. All of the four presentations were insightful and informative to the audience.



## 高雄 Kaohsiung

高雄場由 ico-D 代表 Zachary Haris Ong 於高雄市立美術館揭開序幕。分享自身豐富的創作經驗，暢談自身的創作歷程，以及設計師該如何面對瞬息萬變的市場和適應快速的設計型態。獲得國際多項設計大獎的肯定，國際享譽盛名的平面設計大師 Mehdi Saeedi，透過對文化的觀察，將獨特的觀點轉化為字體設計的理念，從創作作品探索字體之美，激盪出不同的文化的設計想像。來自泰國的 Anurak Suchat，以設計思考為出發點，闡述不同領域的設計觀點，內容豐富多元，引領聽者更多想像。三位講者因不同文化背影的體驗，讓同學有更多面向的思考，期許同學能利用當代設計實務與理論應用，轉化為自身的設計力量。

The Kaohsiung session began with the representative of ico-D, Zachary Haris Ong, at Kaohsiung Museum of Fine Arts. Ong shared his rich creative experience and processes, and he talked about how designers should face the ever-changing market and adapt to the fast pace of design. The globally renowned graphic designer Mehdi Saeedi, acclaimed by many major international design awards, used his observation of cultures and turn his unique viewpoints into concepts of typographical design. His works explore the beauty of characters and spark new design thinking between different cultures. Anurak Suchat from Thailand started with design thinking and elaborated on it from the perspectives of different design areas. His presentation was rich and diverse in content, leading the audience towards more imagination. The three speakers had different cultural backgrounds and experience, which allowed the students to think from multiple dimensions. It is expected that the students can apply the theories and practice of contemporary design and turn them into design strengths.





## 頒獎典禮紀實 Award Ceremony

由教育部青年發展署主辦的「2017 臺灣國際學生創意設計大賽」，吸引來自全球 71 個國家及地區、910 個校院系所的學生報名，總計徵得 18,932 件作品報名參賽，報名作品數超越德國 IF、紅點設計獎等國際競賽，是全球規模最大的國際學生設計競賽。頒獎典禮於 11 月 27 日在臺大醫院國際會議中心舉行，教育部姚立德政務次長也特地蒞臨致詞及頒獎，給予年輕設計者支持與鼓勵。

今年競賽以「Opportunity」為主題，分成產品設計、視覺設計、數位動畫及廠商指定等四類進行比賽。經過初選與決選兩輪專家評選，最終選出年度大獎、各類金、銀、銅獎、佳作、國際設計組織特別獎等獎項共 68 件得獎作品，臺灣學生作品有 31 件。這次四大類金獎，除「產品設計類」外，其餘三類皆由臺灣學生得獎。「視覺設計類」金獎得主，是來自亞洲大學的學生黃聖軒、吳承諭，作品「字蹟」，結合漢字的筆畫，將鹿港知名景點的圖像，勾勒出巧妙的組合；「數位動畫類」金獎由國立臺灣藝術大學的學生盤思妤、陳昭名、陳聖勛奪得，作品「霓虹 Neon」，以霓虹的概念來揭示都會男女的愛情，畫面流暢並富節奏性；「廠商指定類」由《財團法人看見台灣基金會》指定主題（新食器時代－臺灣茶具設計），最後由實踐大學李貞儀同學所創作的「製餅食茶 TeaLab」，將糕餅器具整合進茶具裡，並將茶具拿來製作糕餅，創造出新穎的臺式茶具設計。

另外就讀東海大學的林瑋群、章芸甄同學的「小事 RUKI」是專為亞洲女性設計的生理用品系統，包含月亮杯、外出清潔組和記錄 APP，解決女性在生理期期間因環境衛生所帶來的

不便；記錄 APP 更能精確掌控生理週期的變化。而國立臺灣師範大學的王尹伶同學所創作的「Pick and Throw」探討因近年來漁業發達，人類過度捕撈造成海洋生態的浩劫，海報畫面中的手掌拓印隱喻著如若持續污染，對於海洋生態的危害，終究還是會反撲回人類身上。此 2 位同學作品的意涵深厚，榮獲國際組織特別獎的肯定。16 個國際設計組織特別獎，臺灣學生作品勇奪六項。

其他國家學生也有好表現。年度大獎，是由來自韓國 Kookmin University 學生的作品－「Water Mask Dispenser 吸水式防煙口罩」，因設計操作簡易卻富有功能性，能在危急的時刻拯救性命，於發生災難時，給生命一個生存的機會，契合主題 Opportunity，因此贏得多數評審們青睞，勇奪新臺幣 40 萬元獎金。「產品設計類」金獎是新加坡國立大學的 Chiam Yong Sheng Kevin 同學，以「Folks Kitchenware for the Blind」為一款專為視障人士所改良的廚房用具，創新的設計思維榮獲評審一致好評，獲得新臺幣 25 萬元獎金。同樣來自新加坡的 Jexter Lim Sen Ye，得到國際組織特別獎，巧妙設計出多功能餐具，適用於各年齡層及視障人士，另外印度的 Asish Mohandas，將彈珠汽水原理應用在擔架上，採用易漂浮的材質便於移動患者，同樣獲得國際組織特別獎，得到新臺幣 10 萬元獎金。新南向國家得獎作品數從去年 1 件增加到今年 5 件得獎（分別來自新加坡、印度、馬來西亞、澳洲等 4 國）。2017 年得獎作品展覽，11 月 29 日至 12 月 8 日將於臺北科技大學藝文中心展出。



Organized by the Youth Development Administration of the Ministry of Education, 2017 Taiwan International Student Design Competition attracted students from 71 countries and regions worldwide or from 910 school departments / institutes to participate. The total number of submissions amounted to 18,932, which has surpassed that of iF and Red Dot Design Awards in Germany, making TISDC the largest-scale international design competition for students in the world. The award ceremony took place in the afternoon at NTUH International Convention Center on 27 NOV 2017, during which Political Deputy Minister Yao Leehter of the Ministry of Education delivered his remarks and presented the awards, providing young designers with support and encouragement.

For this year, the theme of the competition was "Opportunity" with four categories: Product Design, Visual Design, Digital Animation and Brand Specified. After the preliminary and final rounds of expert selection, 68 entries received the awards, including the grand prix, golds, silvers, bronzes, honorable mentions and international design association special prizes, among all of which 31 were won by Taiwanese students. Regarding the four gold prizes, except for that of Product Design, the other three were all picked up by students from Taiwan. In the Visual Design category, the gold winners, Sheng-Syuan Huang and Cheng-Yu Wu, came from Asia University. Their work "Finding Taiwan Old Street: Three Scenic Views of Lukang" ingeniously combines strokes of Chinese characters and images of some renowned tourist sites in Lukang. In the Digital Animation category, the gold winners were Sz-Yu Pan, Zhou-Ming Chen and Sheng-Hsun Chen from National Taiwan University of Arts. Their work "Neon" depicts love in an urban context, with smooth and rhythmic images. As for the Brand Specified category, the theme assigned by iSee Taiwan Foundation was Taiwan Teaware Design. Eventually, Chen-Yi Lee from Shih Chien University created "TeaLab" by integrating pastry utensils into teaware. She allowed teaware to be used for pastry making as well, therefore inventing a novel design for Taiwan teaware.

In addition, "RUKI," designed by Wei-Chun Lin and Yun-Jen Jang from Tunghai University, was a set of menstrual products specially made for Asian women, including a menstrual cup, outdoor hygiene tools and a record app, which help women overcome inconvenience during menstrual periods due to unhygienic conditions. Through the record app, users can be better aware of the changes in menstrual cycles. Yin-Ling Wang from National Taiwan Normal University, on the other hand, created "Pick and Throw" to address the issue of overfishing and ecological depletion of the oceans in recent years. On the poster, the palm imprints imply that if pollution continues, the damage brought to the oceans will ultimately return to mankind. These two meaningful works were acclaimed by international design associations. Among the 16 international design association special prizes, students from Taiwan won six.

Students from overseas also performed well. The grand prix was won by students from Kookmin University of South Korea. "Water Mask Dispenser" was simple in design and usage yet strong in functionality. It can save lives in emergency, giving life an

opportunity when disasters strike, which corresponds to the theme "Opportunity." This entry received the approval of most jurors and won the reward sum of 400,000 NTD. The gold prize winner of the Product Design category was Chiam Yong Sheng Kevin from National University of Singapore. His work, "Folks Kitchenware for the Blind," received wide acclaim of the jurors for its innovative design thinking and won 250,000 NTD as a result. Jexter Lim Sen Ye, also from Singapore, won an international design association special prize with his multi-functional tableware, which can be used by the visually impaired of all ages. Asish Mohandas from India, on the other hand, adopted the idea of pinball soda in stretchers. He used easy-to-float materials to facilitate the transfer of patients, so his work also won an international design association special prize with the reward sum of 100,000 NTD. Countries targeted by the New Southbound Policy had won only one prize last year, and this year, the number increased to five (the winners were from Singapore, India, Malaysia and Australia). The exhibition of the 2017 award-winning entries will be held from November 29th to December 8th at Arts & Culture Center Taipei Tech.

## 頒獎典禮紀實 Award Ceremony



教育部姚立德政務次長致詞  
Address by Dr. Leeh-Ter Yao, Political Deputy Minister, Ministry of Education



教育部青年發展署羅清水署長致詞  
Address by Dr. Ching-Shui Lo, Director-General of Youth Development Administration, Ministry of Education



教育部長官及贊助單位兩基金會長官蒞臨指導  
Presence of Ministry of Education, Sayling Wen Cultural & Educational Foundation and iSee Taiwan Foundation Party



臺灣國際學生創意設計大賽十周年獎盃  
TISDC 10th Anniversary Trophy



計畫主持人林磐聳教授致詞與競賽介紹說明  
Address by Project Director Apex Lin and Introduces the Competition

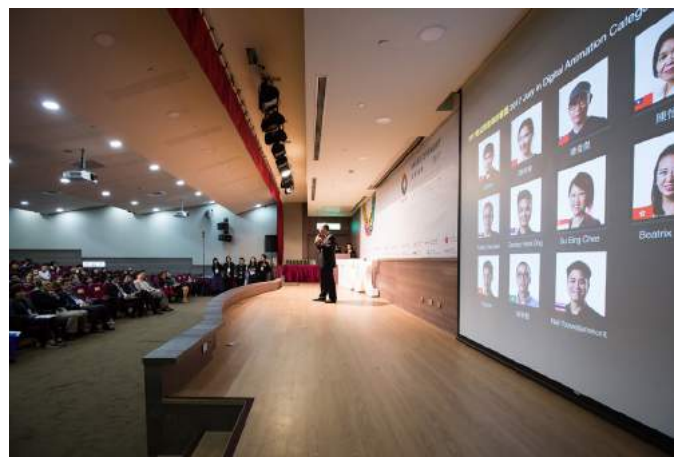





各類別評審召集人說明評選概況  
The Conveners of Judging Panel Give Comments on Each Category



贊助單位《溫世仁文教基金會》執行長何能裕先生  
CEO, Sayling Wen Cultural & Educational Foundation, Mr. Jeter Her



贊助單位《看見台灣基金會》執行長陳文堂先生  
CEO, iSee Taiwan Foundation, Mr. Don Chen



超過百名同學與貴賓一同參與頒獎典禮之盛況  
More than One Hundred Students and Guests Attend the Award Presentation Ceremony



## 頒獎典禮紀實 Award Ceremony



所有得獎者與貴賓合影  
Picture of Winners and Guests



所有國際組織獎的學生與國際組織代表們合影  
Picture of International Design Association Special Prize Winners and Representative of International Design Associations





教育部姚立德政務次長，頒獎給年度大獎得主 Hyunsu Park、Jaeyon Kim、Minseop Woo、Hanna Lee、Chanmi Kim、Wansik Jang 同學代表領取  
 The Grand Prix Winners Hyunsu Park, Jaeyon Kim, Minseop Woo, Hanna Lee, Chanmi Kim, and Wansik Jang (team representative), were Awarded by Dr. Leeh-Ter Yao, Political Deputy Minister, Ministry of Education



年度大獎得獎學生與產品設計類評審張漢寧先生、韓國現代設計協會代表 Yoonho Yoo 先生合照  
 Picture of The Grand Prix Winners, Mr. Jimmy Chang, Juror of Product Design Category and Mr. Yoonho Yoo, Representative of KECD Group Photo



年度大獎得主 Hanna Lee 同學代表組員發表得獎感言  
 Award Acceptance Speech of the Grand Prix Winner, Hanna Lee (team representative)



獲獎師生合照 Picture of Awarded Students and Supervisors Group Photo



## 頒獎典禮紀實 Award Ceremony



新加坡設計業總商會代表 Andrew Pang 先生與池舒穎女士，頒獎給新加坡設計業總商會特別獎得主 Farhana Hossain 同學

The DBCS Green Design Award Winner Farhana Hossain, was Awarded by Mr. Andrew Pang and Ms. Su-Eing Chee, Representative of Design Business Chamber Singapore



香港設計總會代表劉小康先生，頒獎給香港設計總會特別獎得主 Ninaad Kulkarnin 同學

The FHKDA Special Award Winner Ninaad Kulkarnin, was Awarded by Mr. Freeman Lau, Representative of Hong Kong Federation of Design Associations



墨西哥國際海報雙年展協會代表 Xavier Bermudez Bañuelos 先生，頒獎給墨西哥國際海報雙年展協會特別獎得主黃天韻同學、王穎婷同學代表領取

The IPBM Special Award Winners Tien-Yun Huang, and Ying-Ting Wang (team representative), were Awarded by Mr. Xavier Bermudez Bañuelo, Representative of International Poster Biennial in Mexico



國際設計社團協會代表 Zachary Haris Ong 先生，頒獎給國際設計社團協會特別獎得主 Ching-Tien Chu 同學

The ico-D Excellence Award Winner Ching-Tien Chu, was Awarded by Mr. Zachary Haris Ong, Representative of International Council of Design



日本設計振興會代表青木史郎先生，頒獎給日本設計振興會特別獎得主 Asish Mohandas 同學

The JDP Special Award Winner Asish Mohandas, was Awarded by Mr. Shiro Aoki, Representative of Japan Institute of Design Promotion



韓國現代設計協會代表 Yoonho Yoo 先生，頒獎給韓國現代設計協會特別獎得主 爐宏文同學

The KECD Special Award Winner Hong-Wun Lu, was Awarded by Mr. Yoonho Yoo, Representative of Korea Ensemble of Contemporary Design



泰國創意設計中心代表 Apisit Laistrooglai 先生，頒獎給泰國創意設計中心特別獎得主康超同學，由黃曉瑜指導老師代替領取

The TCDC Special Award Winner Chao Kang (Received by Instructor Ms. Xiao-Yu Huang ), was Awarded by Mr. Apisit Laistrooglai, Representative of Thailand Creative & Design Center



捷克布魯諾雙年展協會代表 Jan Rajlich 先生，頒獎給捷克布魯諾雙年展協會特別獎得主 Anna Dmitrieva 同學

The SBB Special Award Winner Anna Dmitrieva, was Awarded by Mr. Jan Rajlich, Representative of Brno Biennale Association



亞洲設計連代表 William Harald-Wong 先生，頒獎給亞洲設計連特別獎得主邱士杰同學代表領取

The tDA Asia Special Award Winner Shih-Chieh Chiu (team representative), was Awarded by Mr. William Harald-Wong, Representative of the Design Alliance Asia



台灣創意設計中心代表宋同正先生，頒獎給台灣創意設計中心最具商品化潛力獎得主 Jexter Lim Sen Ye 同學

The TDC Greatest Market Potential Award Winner Jexter Lim Sen Ye, was Awarded by Mr. Tung-Jung Sung, Representative of Taiwan Design Center



視覺設計類評審楊佳璋先生，頒獎給視覺設計類佳作黃昶維、顏敬安、高在芹、趙于婷及林俊銘同學

The Honorable Mention Prize Winners of Visual Design Category, Chang-Wei Huang, Jing-An Yan, Zai-Cin Gao, Yu-Ting Chao and Chun-Ming Lin, were Awarded by Mr. Martin Yang, Juror of Visual Design Category



## 頒獎典禮紀實 Award Ceremony



產品設計類評審張漢寧先生，頒獎給產品設計類佳作陶俊蓉同學  
The Honorable Mention Prize Winner of Product Design Category, Chun-Jung Tao, was Awarded by Mr. Jimmy Chang, Juror of Product Design Category



視覺設計類評審陳重宏先生，頒獎給數位動畫類佳作齊慕夷同學代表領獎  
The Honorable Mention Prize Winner of Digital Animation Category, Mu-Yi Chi (team representative), was Awarded by Mr. Chung-Hung Chen, Juror of Visual Design Category



教育部姚立德政務次長，頒獎給產品設計類金獎 Chiam Yong Sheng Kevin 同學、視覺設計類金獎黃聖軒、吳承諭同學及數位動畫類金獎陳聖助同學代表領取  
The Gold Prize Winner of Product Design Category, Chiam Yong Sheng Kevin, the Gold Prize Winners of Visual Design Category, Sheng-Syuan Huang and Cheng-Yu Wu, the Gold Prize Winner of Digital Animation Category, Sheng-Hsun Chen (team representative), were Awarded by Dr. Leeh-Te Yao, Political Deputy Minister, Ministry of Education





教育部姚立德政務次長，頒獎給視覺設計類銀獎姚凱倫同學

The Silver Prize Winner of Visual Design Category, Kai-Lun Yao, was Awarded by Dr. Leeh-Ter Yao, Political Deputy Minister, Ministry of Education



教育部姚立德政務次長，頒獎給產品設計類銅獎 Janis Beinerts、Susanne Duswald 同學、陳彥廷、陳彥廷同學代表領取、陳子捷、袁千涵同學

The Bronze Prize Winners of Product Design Category, Janis Beinerts, Susanne Duswald, Yen-Tin Chen, Yen-Ting Chen (team representative), Zih-Jie Chen and Chien-Han Yuan, were Awarded by Dr. Leeh-Ter Yao, Political Deputy Minister, Ministry of Education



教育部姚立德政務次長，頒獎給視覺設計類銅獎林健均、楊采菱、楊雅筑同學、朱天航同學、鄒云岱同學

The Bronze Prize Winners of Visual Design Category, Jie-Jun Lin, Tsai-Ting Yang, Ya-Chu Yang, Tian-Hang Zhu, and Yun-Dai Zou, were Awarded by Dr. Leeh-Ter Yao, Political Deputy Minister, Ministry of Education

## 頒獎典禮紀實 Award Ceremony



教育部姚立德政務次長，頒獎給數位動畫類銅獎 Jihyeon Bae 同學、楊凱雲同學代表領取、周浩然同學（同學代替領取）

The Bronze Prize Winners of Digital Animation Category, Jihyeon Bae, Kai-Yun Yang (team representative), and Harry Zhou (his friend representative), were Awarded by Dr. Leeh-Te Yao, Political Deputy Minister, Ministry of Education



計畫主持人林磐聳教授，頒獎給廠商指定類-看見台灣基金會創新設計獎金獎李貞儀同學

The Gold Prize Winner of Brand Specified Category-iSee Taiwan Foundation Innovative Design Awards, Chen-Yi Lee, was Awarded by Prof. Apex Lin, Project Director of TISDC





計畫主持人林磐聳教授，頒獎給廠商指定類-看見台灣基金會創新設計獎銀獎張玉樺同學代表領獎、田文成、薛邁同學(同學代替領取)

The Silver Prize Winners of Brand Specified Category-iSee Taiwan Foundation Innovative Design Awards, Yu-Hua Jhang (team representative), Wen-Cheng Tian and Mai Xue (their friend representative), were Awarded by Prof. Apex Lin, Project Director of TISDC



計畫主持人林磐聳教授，頒獎給廠商指定類-看見台灣基金會創新設計獎銅獎徐瑄惠、黃弘宇同學、蕭翎軒同學、李玖函同學、姜標、王新元、李嘉良、陳靜同學(同學代替領取)

The Bronze Prize Winners of Brand Specified Category-iSee Taiwan Foundation Innovative Design Awards, Hsuan-Hui Hsu, Hung-Yu Huang, Ling-Xuan Xiao, Wen-Han Li, Biao Jiang, Xin-Yuan Wang, Jia-Liang Li, and Jing Chen (their friend representative), were Awarded by Prof. Apex Lin, Project Director of TISDC



計畫主持人林磐聳教授，頒獎給廠商指定類-看見台灣基金會創新設計獎佳作呂俊翰同學、湯睿峰同學代表領取

The Honorable Mention Prize Winners of Brand Specified Category-iSee Taiwan Foundation Innovative Design Awards, Jun-Han Lu and Jui-Feng Tang (team representative), were Awarded by Prof. Apex Lin, Project Director of TISDC



獲獎學生接受媒體採訪

Awarded Students Interview by Press



## 展覽紀實 Exhibition

本屆獲獎作品展覽於 2017 年 11 月 29 日至 12 月 8 日臺北科技大學藝文中心舉辦，展出自 18,932 多件參賽作品中脫穎而出的 68 件獲獎作品，作品涵蓋產品設計、視覺設計、數位動畫及廠商指定類，分別以海報掛軸方式呈現，開放一般民眾參觀。本次展出作品不僅充分展現參賽學生對主題「Opportunity」的詮釋，更反映了新生代對當代社會的多面向思考。11 月 27 日頒獎典禮後，還可看見來自國內外的獲獎者、與會設計師及廠商於展覽會場交流及欣賞作品，期待能藉此開啟設計界更多國際間、產學間的合作機會。

Winning works from this year's competition were exhibited from November 29 to December 8, 2017 at the Arts & Culture Center Taipei Tech. The 68 best winning works from a total of 18,932 entries were exhibited. The works are divided into Product Design, Visual Design, Digital Animation and Brand Specified Categories, and presented to the general public in the form of the hanger shafting of poster. The 68 works exhibited in this gallery not only demonstrate the students' interpretation of the theme titled "Opportunity", it also reflects the younger generation's contemplation of our modern society. After the Award Ceremony on November 27, award winners from Taiwan and other countries gathered together with designers and industry representatives to discuss and appreciate various artworks with the hopes of initiating collaborative opportunities for design projects between different countries, and between the academia and the industry.

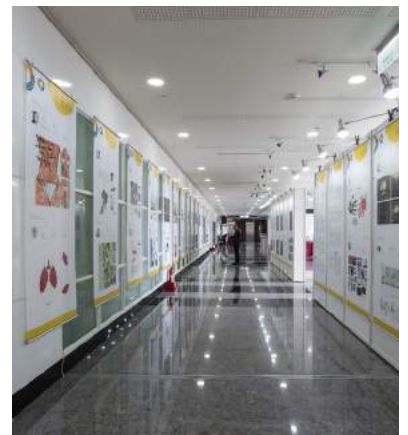



臺大醫院國際會議中心展覽狀況 During Exhibition at NTUH International Convention Center



臺北科技大學藝文中心展覽狀況 During Exhibition at the Arts & Culture Center Taipei Tech



## 新亞洲設計工作坊 New Asia Design Workshop

「新亞洲設計工作坊」於 2017 年 5 月 27 日至 5 月 28 日在亞洲大學展開，來自臺灣各高中職及大專院校之學生共同參與，並邀集三位來自新南向國家具領導地位的國際級設計師，印度的 Subrata Bhowmick、新加坡的 Kelley Cheng 及菲律賓的 Dino Brucelas 齊聚一堂擔任工作坊講師，不僅促進國際交流，更讓喜愛設計的學員們能親臨現場向國際級大師學習。

New Asia Design Workshop was held on 27th and 28th May 2017 at Asia University, with the participation of high school and university students from all over Taiwan. The Workshop invited three leading international design masters as instructors, and they came from three countries targeted by the New Southbound Policy: Subrata Bhowmick from India, Kelley Cheng from Singapore and Dino Brucelas from the Philippines. This occasion not only facilitated international exchanges but also allowed design-loving students to have a chance to learn from international masters in a face-to-face manner.



產品設計類組邀請來自新加坡的設計師 Kelley Cheng 擔任工作坊指導老師  
Product Design Category Invited Ms. Kelley Cheng from Singapore as the Workshop Instructor

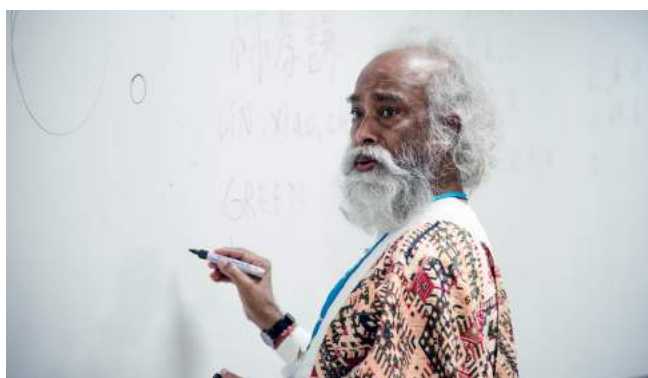

視覺設計類組邀請來自印度的設計師 Subrata Bhowmick 擔任工作坊指導老師  
Visual Design Category Invited Mr. Subrata Bhowmick from India as the Workshop Instructor



數位動畫類組邀請來自菲律賓的設計師 Dino Brucelas 擔任工作坊指導老師  
Digital Animation Category Invited Mr. Dino Brucelas from the Philippines as the Workshop Instructor



工作坊主要以競賽主題「Opportunity」及「新食器時代－臺灣茶具設計」為核心，帶領學員們透過創意的發想與演繹，提供不同設計領域各種面向的觀察與思考，並運用概念完成設計作品。期待透過此工作坊，提供學員們與國際設計師交流及學習的平台，帶來新的視野，激發出不同的創意火花。

The core of the Workshop was the themes for the Taiwan International Student Design Competition: "Opportunity" and "Taiwan Teaware Design." The Workshop led students to exercise creative thinking and interpretation, provided them with diverse observation and ideation perspectives in different design areas, and encouraged them to turn their concepts into a final design work. It is expected that through this Workshop, students can be given a platform to learn from and carry out exchanges with international designers, with whom they broaden their horizon and spark new fire of creativity.



新亞洲設計工作坊大合照  
New Asia Design Workshop Group Photo



新亞洲設計工作坊演講實況  
New Asia Design Workshop Speech Section



新亞洲設計工作坊成果發表 New Asia Design Workshop Final Presentation





## 海內外歷屆作品展覽 Domestic and International Exhibitions

本年度於國內外舉辦歷屆作品展覽，分別於新竹多媒體藝術展、國立海洋大學、陽明海洋文化藝術館、崇右影藝科技大學、經國管理暨健康學院、國立海洋大學三創基地、東南科技大學、醒吾科技大學、國立臺中科技大學、亞洲大學；海外展覽分別於中國大陸四川成都 - 漢鼎藝術中心、印度設計委員會、越南日航河內飯店、國立越南美術大學、越南 Nguyen Trai 大學、越南 FPT 大學、馬來西亞萬達大學、馬來西亞藝術學院、寮國國家文化廳、寮國國立大學，向國人及國際展示臺灣年輕設計競爭力。

This year, the executive held ten exhibitions of past years' winning pieces in Taiwan: Hsinchu Multimedia Art Exhibition, National Taiwan Ocean University, YM Oceanic Culture & Art Museum, Chungyu University of Film and Arts, Ching Kuo Institute of Management and Health, National Taiwan Ocean University Syntrend Platform, Tungnan University, Hsing Wu University, National Taichung University of Science and Technology, and Asia University. Overseas: Han-Ding Art Center in Chengdu, China, India Design Council, Nikko Hanoi Hotel, Vietnam University of Fine Art, Nguyen Trai University, FPT University, First City University College, Malaysian Institute of Arts, Laos National Culture Hall, and Laos National University, showing the people and the world the competitiveness of Taiwan young design generation.



印度設計委員會展覽現場 The Exhibition Venue at India Design Council



越南 Nguyen Trai 大學展覽現場 The Exhibition Venue at Nguyen Trai University



越南日航河內飯店展覽現場 The Exhibition Venue at Nikko Hanoi Hotel



國立越南美術大學展覽現場  
The Exhibition Venue at Vietnam University of Fine Art



亞洲大學展覽現場  
The Exhibition Venue at Asia University



經國管理暨健康學院展覽現場  
The Exhibition Venue at Ching Kuo Institute of Management and Health



國立臺中科技大學展覽現場  
The Exhibition Venue at National Taichung University of Science and Technology



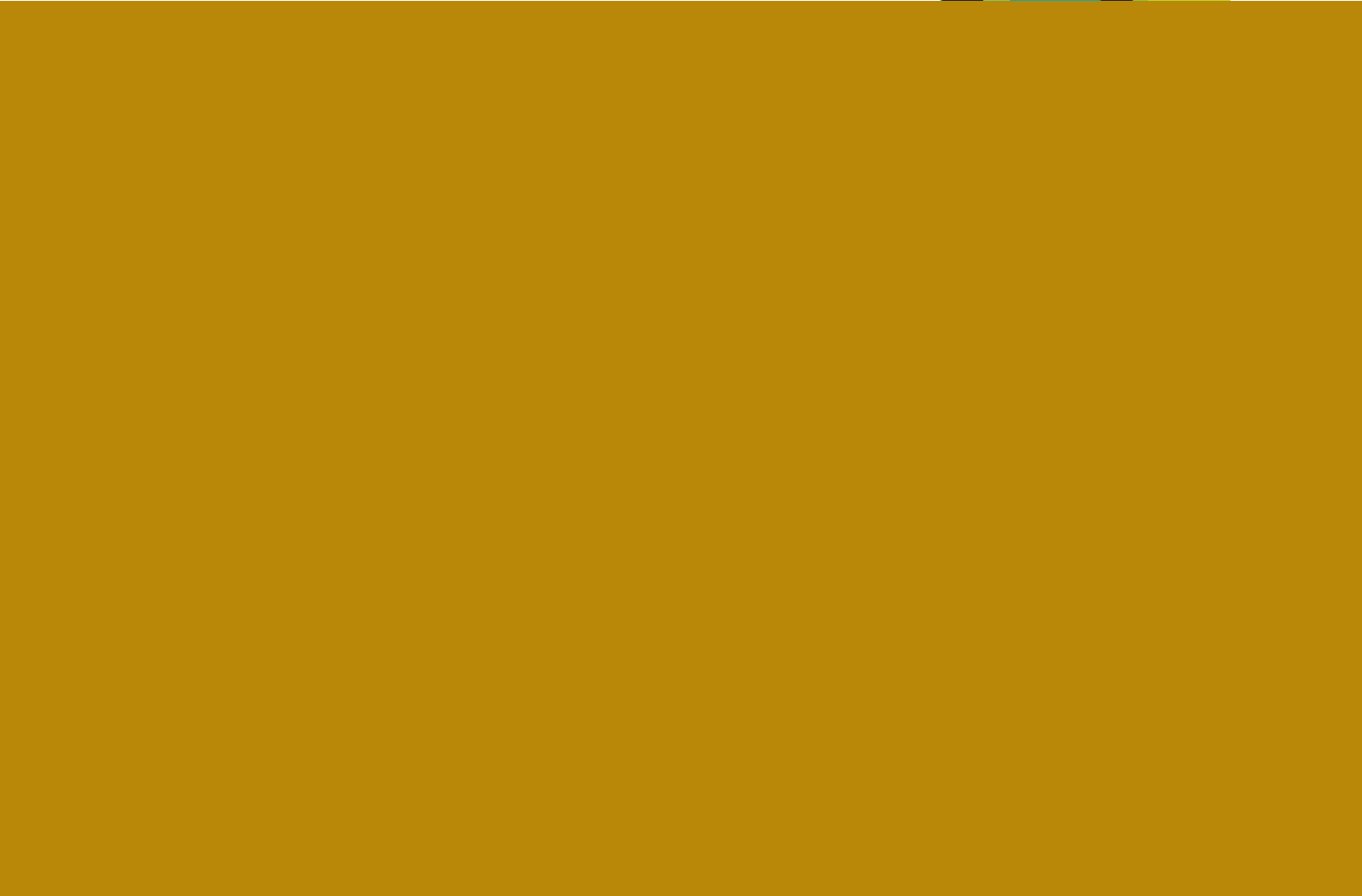



2017

# Opportunity

---

大賽人員介紹

Staff Introduction

## 大賽人員介紹 Staff Introduction



計畫主持人  
*Project Director*

林磐聳 **Apex Lin, Pang-Soong**



計畫協同主持人  
*Associate Project Director*

游明龍 **Ming-Lung Yu**



計畫協同主持人  
*Associate Project Director*

李新富 **Shin-Fu Lee**



計畫協同主持人  
*Associate Project Director*

廖偉民 **Wei-Ming Liao**



計畫協同主持人  
*Associate Project Director*

張天捷 **Tien-Chieh Chang**



計畫協同主持人  
*Associate Project Director*

林孟潔 **Miira Lin**





專案經理  
*Project Manager*

洪誼新 **Annie Hung**



專案經理  
*Project Manager*

曾家薇 **Clementine Tseng**



專案經理  
*Project Manager*

黃維萱 **Wendy Huang**



專案經理  
*Project Manager*

黃郁璇 **Jenny Huang**



專案經理  
*Project Manager*

楊安琪 **Angel Yang**

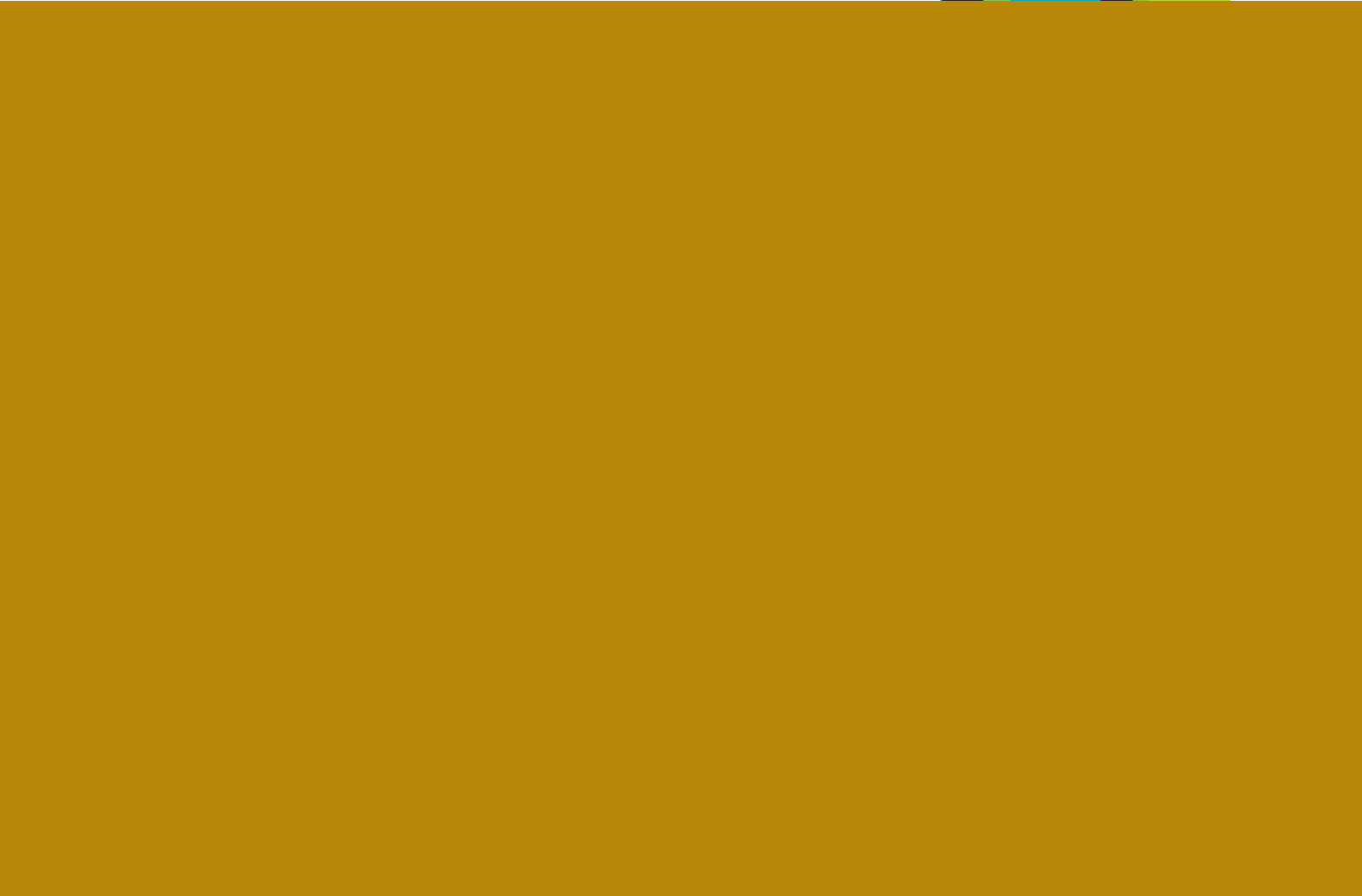



2017

# Opportunity

附錄－競賽簡介

Appendix - Competition Regulation







# Opportunity

---

面對挑戰 選擇機會

整合資源 創造價值

*Opportunity*

*Global Challenge, Design Opportunity*

---



## 活動目的

鼓勵國際間學生創意設計交流，發掘新生代創意設計人才。

## 活動主題

Opportunity

## 活動特色

- 全球學生設計大賽總獎金高達新臺幣 480 萬元
- 全球最大規模的國際學生設計大賽
- 全球 16 個國際設計組織授權合作設置獎項
- 免報名費及參展費

## 參賽資格

限定國內外高級中等以上學校在校學生（以網路截止報名時間為準，須為西元 1987 年 5 月 29 日之後出生，年齡 30 歲以內。女性申請人於申請年限之前曾有生育事實者，每胎得延長年限兩年）  
※ 應屆畢業生（2017 年 6 月畢業）及新生（2017 年 9 月入學）皆可報名參加。

## 徵件需求

能表達競賽主題「Opportunity」之創意設計

## 參賽類別

產品設計、視覺設計、數位動畫、廠商指定，共四類

## 報名費用

免繳報名費

## 參賽時間表

線上報名及參賽作品送件截止

2017 年 6 月 1 日至 2017 年 7 月 25 日，臺北時間 24:00 (GMT+08:00)

初選

2017 年 9 月 2 - 4 日

入圍名單公告並通知第二階段交件

2017 年 9 月 12 日

決選

2017 年 10 月 6 日

頒獎典禮

2017 年 11 月 27 日

獲獎作品展覽

2017 年 11 月 29 日 - 12 月 8 日



## 報名程序



請注意：

- 為保障參賽者權益，報名時請填入經常使用的 E-mail 信箱，執行單位將會以此信箱傳送比賽重要訊息，包含入圍與得獎通知。
- 主辦機關將寄發年度專刊與證書給所有得獎及入圍者，請務必於報名時填寫正確之收件地址。
- 報名截止後，將無法再修改作品名稱及參賽者姓名，請妥為填寫。
- 為保障所有參賽者的權利與義務、保護智慧財產權並使競賽順利推動，亦請務必妥善填寫「參賽聲明同意書及著作授權同意書」。

## 決選送件

A. 下載「參賽聲明同意書及著作授權同意書」

B. 上傳決選參賽文件

1. 「學生身分證證明文件」掃描檔（所有創作者皆需具備證明文件）
2. 「出生年月日證明文件」掃描檔（所有創作者皆需具備證明文件）
3. 填妥並簽署的「參賽聲明同意書及著作授權同意書」掃描檔（每件作品務必填寫一份。若為小組報名，由一人代表填寫即可。）

a. 產品設計類入圍者請繳交以下項目：

1. 作品輸出：請輸出實體說明海報，每張 A2 大小 (42X59.4 cm)，每件作品至多 3 張，不需裱裝於裱卡或裱板上。海報內容說明文字必須以英文為主。
2. 作品電子檔上傳：包括作品說明海報與產品照數位檔案（JPG 檔，300dpi，印刷品質，CMYK 模式）、所有設計者之清晰半身照片（2MB 以上，JPG 檔，300dpi）。

b. 視覺設計類入圍者請繳交以下項目：

1. 作品輸出：每張 A2 大小 (42X59.4 cm)。每件作品至多 3 張，不需裱裝於裱卡或裱板上。
2. 作品電子檔上傳：包含原寸作品檔案（JPG 檔，300dpi，印刷品質，CMYK 模式）、所有設計者之清晰半身照片（2MB 以上，JPG 檔，300dpi）。

c. 數位動畫類入圍者請繳交以下項目：

- 作品電子檔上傳：包括作品正片（10 分鐘以內，800MB 以內，MOV/MP4 檔）、作品宣傳圖 5 張以內（JPG 檔，300dpi）、所有設計者之清晰半身照片（2MB 以上，JPG 檔，300dpi）

d. 廠商指定類入圍者請繳交以下項目：

1. 作品輸出：請輸出實體說明海報，每張 A2 大小 (42X59.4 cm)，每件作品至多 4 張，不需裱貼於裱卡或裱板上。海報內容說明文字必須以英文為主。
2. 作品電子檔上傳：包括作品說明海報與產品照數位檔案（JPG 檔，300dpi，印刷品質，CMYK 模式）、所有設計者之清晰半身照片（2MB 以上，JPG 檔，300dpi）。



## 作品寄送地址 |

2017 臺灣國際學生創意設計大賽執行小組  
亞洲大學視覺傳達設計學系 A412 計畫辦公室收  
41354 臺中市霧峰區柳豐路 500 號

作品上傳網址 | [www.tisdc.org](http://www.tisdc.org)

※ 請注意：作品請妥善包裝後寄出，運送過程中若對作品造成損傷而影響評審觀感，主辦機關恕不負責。

## 評選作業

初選 | 依照參賽者所提供之作品電子檔為依據，由評選委員會選出晉級決選的作品。

決選 | 產品設計類、視覺設計類及廠商指定類均以入圍者自行輸出之說明海報進行評選；數位動畫類以作品數位檔案進行評選。

## 評審標準

以創意出發，力求突破，切合主題並能表達主題概念與美感的設計。執行單位將邀請國內外不同領域專家組成初、決選評審團進行評選。

產品設計類 | 創意 50%，切題性 30%，圖面表達 20%

視覺設計類 | 創意 50%，切題性 30%，構圖與美感 20%

數位動畫類 | 創意 50%，美感 30%，切題性 20%

廠商指定類 | 創意 50%，量產可行性 50%

## 頒發獎項

### 產品設計、視覺設計與數位動畫類

- 年度大獎 1 名：獎金新臺幣四十萬元，獎盃一座，獎狀一紙
- 金獎（產品、視覺、動畫各 1 名）：獎金新臺幣二十五萬元，獎盃一座，獎狀一紙
- 銀獎（產品、視覺、動畫各 1 名）：獎金新臺幣十五萬元，獎盃一座，獎狀一紙
- 銅獎（產品、視覺、動畫各 3 名）：獎金新臺幣六萬元，獎盃一座，獎狀一紙
- 佳作（若干名）：獎金新臺幣一萬元，獎狀一紙

國際設計組織特別獎（16 名）：獎金新臺幣十萬元，獎盃一座，獎狀一紙

### 廠商指定類

看見台灣基金會創新設計獎－「新食器時代－臺灣茶具設計」

- 金獎（1 名）：獎金新臺幣二十五萬元，獎盃一座，獎狀一紙
- 銀獎（2 名）：獎金新臺幣十五萬元，獎盃一座，獎狀一紙
- 銅獎（4 名）：獎金新臺幣六萬元，獎盃一座，獎狀一紙
- 佳作（若干名）：獎金新臺幣一萬元，獎狀一紙

※ 以上各獎項經決選評審小組決議，得從缺或調整；同一作品於同一年度曾在政府中央部會主辦之相關競賽或教育部「鼓勵學生參加藝術與設計類國際競賽」之表列競賽項目中獲獎者，由決選評審小組擇優核定獎勵金額，不受前項獎金額度限制。獎盃與獎狀以教育部部長名義頒發，並於今年年底舉行頒獎典禮。所有得獎者將公布於官方網站及國內外媒體，以提供廠商進行設計合作案之相關洽詢。

## 注意事項

### 關於參賽作品 |

- 所有參賽作品均不予退件。
- 參賽者可以個人或組隊參賽，參賽件數不限。
- 同一件作品不得跨類別重複投遞。
- 作品須為參賽者自行創作且具原創性。
- 所有概念、文字、圖案、表格、照片、影片、語音、音樂、動畫等各種內容及所使用之程式無仿冒、抄襲或其他侵害他人智慧財產權及著作權之情事。

### 關於參賽者 |

- 同意接受並遵守本活動注意事項及規範，如有違反本活動注意事項及規範之行為，經查證屬實，活動單位得取消其參賽或得獎資格，並對於任何破壞本活動之行為保留相關權利。
- 尊重本獎評審小組之決議。
- 報名參賽時，同一作品已發表、曾在其他比賽獲獎或正在評審中，應於參賽聲明同意書註明，並主動告知教育部及本賽執行單位，作為政府頒發獎金之參考依據。
- 不得有請託、關說、利誘、威脅或其他干擾評審委員及評審程序之情事。
- 參賽者須配合提供其創作之詳細資料，作為日後公開報導與展示之用。
- 前三名及廠商指定類得獎者請親至頒獎典禮受獎，需自付參加頒獎典禮之旅費及來臺簽證相關手續費用。

## 關於得獎者

- 提供得獎作品之詳細資料，作為公開報導及展示之用。
- 在公告得獎三年內，得獎者與其得獎作品應配合由教育部所舉辦之相關展示與宣導活動，並保留作品原始檔案及資料，供教育部備查。
- 得獎獎金應依規定課稅。
- 得獎作品應同意無償、非專屬性授權教育部及本賽執行單位，使用參賽獲選作品圖片與說明文字等相關資料，製作成視聽著作（影片）與數位形式檔案，提供教學、研究與公共服務用途之公開上映、公開播送與網路線上閱覽。若因教學研究之需求，教育部得重製該作品。本件授權不影響著作人對原著作之著作權及衍生著作權，並得為其他之專屬授權。
- 得獎作品其後續商品化及行銷行為，不得損害本獎之形象或精神。
- 廠商指定類金獎、銀獎以及銅獎作品廠商有權使用、生產、製造與出版相關事宜。

## 關於獲獎資格取消

參賽者及其作品有下列情事之一，經查證屬實者，取消得獎資格，並追回已領之獎盃、獎狀及獎金：

- 未符合參賽資格。
  - 得獎作品經人檢舉涉及抄襲或違反著作權等相關法令，經法院判決確定者。
  - 得獎作品經人檢舉或告發為非自行創作或冒用他人作品且有具體事證，經查證、審議，裁決應取消獲獎資格者。
  - 得獎作品其後續商品化及行銷行為，有損害本獎之形象或精神者。
  - 得獎者有請託、關說、利誘、威脅或其他干擾評審委員或評審程序，經初選評審小組審議後認情節嚴重者。
- ※ 主辦機關保留活動變動之權利，本活動未竟事宜，依教育部函示規定及網站公布為準。有關爭議，經活動評審小組審議後，報教育部決定之。

## 聯絡方式

2017 臺灣國際學生創意設計大賽執行小組  
亞洲大學視覺傳達設計學系  
地址：41354 臺中市霧峰區柳豐路 500 號  
TEL：+886-4-2331-0066 & 2331-0099  
FAX：+886-4-2331-0099  
E-mail：[tisdc.tw@gmail.com](mailto:tisdc.tw@gmail.com)  
Website：[www.tisdc.org](http://www.tisdc.org)  
Facebook：臺灣國際學生創意設計大賽

## Purpose

Encourage international creative design exchange, develop creative design talents, express the international image of Taiwan attaching great importance to creative design, and establish the international design status of Taiwan.

## Theme

Opportunity

## Qualification

- Total Prize is Up to USD\$160,000
- The Largest Student Design Competition Worldwide
- 16 International Design Associations Endorse Special Awards
- No Registration & Presentation Fee

## Qualification

Students who currently enroll at senior high schools or above (Based on the internet registration deadline, and the participant must be born after May 29, 1987, and younger than 30 years of age. For females who have given birth before year of 30 may have 2 years extension per birth.).

\*Fresh graduates (graduate in June 2017) and new students (enroll school in September, 2017) are also eligible.

## Participating Works

The creative design of the competition theme "Opportunity" must be expressed in the participating pieces.

## Category

Product Design, Visual Design, Digital Animation, and Brand Specified

## Registration Fee

Free

## Timetable

### Online Registration and Online Work Submission

June 1, 2017 to July 25, 2017, 24:00 (Taipei GMT+08:00)

### Preliminary Selection

September 2-4, 2017

### Finalists Announcement

September 12, 2017

### Delivery Deadline of Final Selection Submission

Finalists will be asked to submit printouts and upload works for the Final Selection. Related information and the deadline will be noticed in the finalist announcement.

### Final Selection

October 6, 2017

### Award Ceremony and Exhibition

November 27, 2017

## Participation Procedure

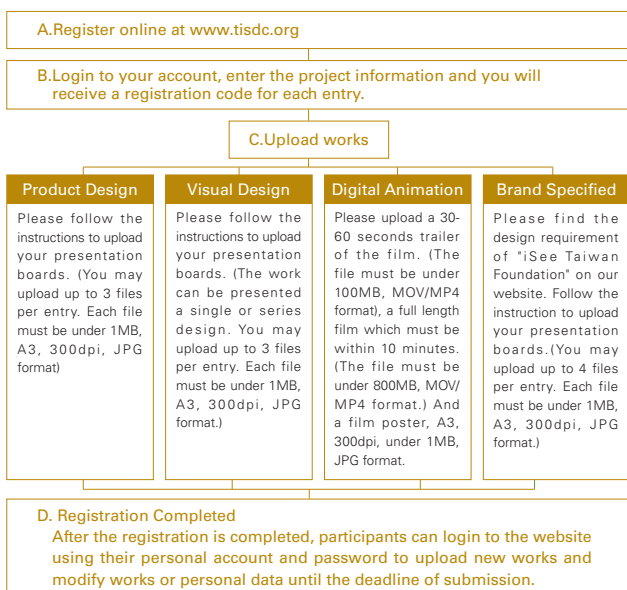

Please note:

- Please provide the most frequently used E-mail, to which the executive will send important information regarding the competition, including the finalist and winner announcements.
- The organizer will send the annual portfolio and certificate to every finalist. Please make sure to fill in the valid mailing address when registering.
- After the deadline of online registration, all information about the entry cannot be modified, so please fill in the information carefully.
- To protect intellectual property and ensure participating rights and interests, participants must fill out the Affidavit for each entry and upload its scanned copy.

## Final Selection Submission Procedure

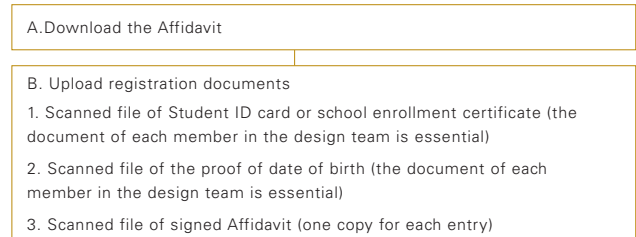

### A. Product Design Category |

Printout(s):

Please submit at most 3 printouts of your presentation boards, each piece on A2 size (42X59.4 cm). The printouts need not be mounted on cardboards/paperboards. The descriptions on the boards should be in English.

Upload works: Electronic documents should include:

\*Digital archives of the posters and product photos (JPG/300dpi/press quality/CMYK)

\*Clear half-length photos of all designers (above 2MB/JPG/300dpi)

### B. Visual Design Category |

Printout(s):

Please submit a maximum of 3 posters describing each piece on A2 size (42X59.4 cm) paper. The printouts need not be mounted on cardboards/paperboards.

Upload works: Electronic documents should include:

\*The electronic file of the work(s), in original size (JPG/300dpi/press quality/CMYK)

\*Clear half-length photos of all designers (above 2MB/JPG/300dpi)

### C. Digital Animation Category

Upload works: Electronic documents should include:

\*A full length film which must within 10 minutes. (The file must be under 800MB, MOV/MP4 format.)

\*At most 5 stills/promotion images of the film (JPG/300dpi)

\*Clear half-length photos of all designers (above 2MB/JPG/300dpi)

### D. Brand Specified Category |

Printout(s):

Please submit at most 4 printouts of your presentation boards, each piece on A2 size (42X59.4 cm). The printouts need not be mounted on cardboards/paperboards. The descriptions on the boards should be in English.

Upload works: Electronic documents should include:

\*Digital archives of the posters and product photos (JPG/300dpi/press quality/CMYK)

\*Clear half-length photos of all designers (above 2MB/JPG/300dpi)

### Mailing Address |

2017 Taiwan International Student Design Competition Executive Department of Visual Communication Design, Asia University A412 Project Office, No.500, Lioufeng Rd., Wufeng Dist., Taichung City 41354, Taiwan

### Upload Link | [www.tisdc.org](http://www.tisdc.org)

※Please note: The printouts should be packed properly before delivering. The organizer is not responsible for any damage of art works during the delivery process.

### Evaluation Operation

#### A. Preliminary Selection |

The evaluation will be based on the digital files provided by the participants. The evaluation committee will select finalists for the final selection.

#### B. Final Selection |

Finalists in Product Design category, Visual Design category and Brand Specified category will be judged according to the printout works submitted by the participants. In Digital Animation category, the nominated films will be evaluated according to the digital files.

## Evaluation Criteria

The design works will be judged on their creativity, interpretation of the theme, expression of concept, and aesthetic approach. Domestic and international experts in different fields will be invited to organize the preliminary and final selection committee to process the evaluation.

### A. Product Design Category

Creativity: 50%; Thematic: 30%; Design Presentation: 20%

### B. Visual Design Category

Creativity: 50%; Thematic: 30%; Composition and Aesthetics: 20%

### C. Digital Animation Category

Creativity: 50%; Aesthetics: 30%; Thematic: 20%

### D. Brand Specified Category

Creativity: 50%; Manufacturing Feasibility: 50%

## Awards

### Product Design, Visual Design, and Digital Animation Categories

Grand Prix (1 winner):

NT\$400,000 (approx. US\$13,000), an awarding cup and a certificate

Gold Prize (1 winner for each category):

NT\$250,000 (approx. US\$8,000), an awarding cup and a certificate

Silver Prize (1 winner for each category):

NT\$150,000 (approx. US\$5,000), an awarding cup and a certificate

Bronze Prize (3 winners for each category):

NT\$60,000 (approx. US\$2,000), an awarding cup and a certificate

Honorable Mention Prize (several winners for each category):

NT\$10,000 (approx. US\$330) and a certificate

### International Design Association Special Prize (16 winners):

NT\$100,000 (approx. US\$3,300), an awarding cup and a certificate

### Brand Specified Category:

iSee Taiwan Foundation Innovative Design Awards - Taiwan Teaware Design

Gold Prize (1 winner for each category):

NT\$250,000 (approx. US\$8,000), an awarding cup and a certificate

Silver Prize (2 winner for each category):

NT\$150,000 (approx. US\$5,000), an awarding cup and a certificate

Bronze Prize (4 winners for each category):

NT\$60,000 (approx. US\$2,000), an awarding cup and a certificate

Honorable Mention Prize (several winners for each category):

NT\$10,000 (approx. US\$330) and a certificate

※The prizes will be adjusted according to the quality and quantity of participating works.

※The awarding cup and the certificate will be conferred by the Minister of Education and the Award Ceremony will take place in November.

※The winners will be announced on our official website and other media in Taiwan and abroad, to allow suppliers to seek for design cooperation opportunities.

## Terms & Conditions

### For the entries |

- All entries will not be returned.
- Entrants can participate in the competition as individuals or in teams. Multiple submissions of different works are acceptable.
- Multiple submissions of the same work in two or more categories are not allowed.
- The entries must be original and creative by the participants themselves.
- All the concepts, text, icons, sheets, pictures, videos, audios, music, animation contents and program of the work shall not be involved in any plagiarism or infringement of copyrights or other laws.

### For the entrants |

- All entrants shall accept the regulations of TISDC. Participating qualifications or prizes will be cancelled if the violation is proved and the organizer shall have the rights to take actions.
- The entrants shall respect the evaluation and decisions made by the committee.
- If the participating work has been published, awarded or is under evaluation process in other competitions, the entrant shall clearly indicate the fact in the Affidavit and inform the organizer.
- Requests, lobbies, threats, bribes or other actions interfering in the evaluation are not allowed.
- The entrants shall agree to provide the detail information of the entries for future media coverage and exhibitions.
- The top three and special prize winners in Product Design, Visual Design, and Digital Animation category, and the winners in Brand Specified category shall be present at the Award Ceremony. All travel expenses related to the award

ceremony will be borne by the participants.

### For the winners |

- The winners shall agree to provide the detail information of the works for future media coverage and exhibitions.
- The winners shall cooperate with the organizer in promotion and education activities for 3 years since the proclaiming of awarding.
- All monetary prizes will be taxed according to the regulations of Taiwan government. (The winners from abroad will be taxed at the rate of 20%.)
- For promotion purposes, the organizer shall have the rights to utilize (including but not limited to reproduce, public recitation, public broadcast, public presentation, public transmission, distribution, public display, publication, public release) the awarded works in different formats, including but not limited to Video/CD recordings, catalogues, photos, publications, and exhibitions.
- The commercialization and marketing activities of the awarded works shall not contravene the spirit of the competition.
- The sponsorship of Gold Prize and Silver Prize and Bronze Prize in Brand Specified category shall be entitled to use, production, manufacturing and publishing related matters of the winners' works.

※In any of the following condition, the organizer shall have the rights to disqualify the awarded winners and revoke the prizes, awarding cups and certificates:

- In the event that the participant does not meet the qualification.
- In the event that the awarded work is involved in plagiarism or infringement of copyrights or other laws.
- In the event that the awarded work is proven to be unoriginal design, or to have fraudulently copied ideas from other person's work.
- In the event that the commercialization and marketing activities of the awarded work contravene the spirit of this competition.
- In the event that the entrant is involved in request, lobby, threat, bribe or other actions which interfere the evaluation.

※The organizer reserves the right to make alterations, which will be announced on the official website. If there should be any controversial issue, it will be deliberated and judged by the committee before reporting to the organizer the Ministry of Education for the final resolution.

## Contact

2017 Taiwan International Student Design Competition Executive  
Department of Visual Communication Design, Asia University  
ADD: No.500, Lioufeng Rd., Wufeng Dist., Taichung City 41354, Taiwan  
TEL: +886-4-2331-0066 & 2331-0099  
FAX: +886-4-2331-0099  
E-mail: tisd.c.tw@gmail.com  
Website: www.tisd.c.org  
Facebook: Taiwan International Student Design Competition

### 主辦機關 Organizer

教育部青年發展署  
The Youth Development Administration, Ministry of Education

### 贊助單位 Sponsors

看見台灣基金會 iSee Taiwan Foundation  
溫世仁文教基金會 Sayling Wen Cultural & Educational Foundation

### 執行單位 Executive

亞洲大學視覺傳達設計學系  
Department of Visual Communication Design, Asia University

### 全球夥伴 Worldwide Partners

法國設計師聯盟 Alliance Francaise des Designers  
捷克布魯諾雙年展協會 Brno Biennale Association  
新加坡設計業總商會 Design Business Chamber Singapore  
澳大利亞優秀設計協會 Good Design Australia  
德國國家設計委員會 German Design Council  
香港設計總會 Hong Kong Federation of Design Associations  
國際設計社團協會 International Council of Design  
印度設計委員會 India Design Council  
墨西哥國際海報雙年展協會 International Poster Biennial in Mexico  
日本設計振興會 Japan Institute of Design Promotion  
韓國現代設計協會 Korea Ensemble of Contemporary Design  
澳門設計師協會 Macau Designers Association  
亞洲設計連 The Design Alliance Asia  
泰國創意設計中心 Thailand Creative & Design Center  
台灣創意設計中心 Taiwan Design Center  
紐西蘭設計師協會 The Designers Institute of New Zealand





# Opportunity

2017 臺灣國際學生創意設計大賽  
2017 Taiwan International Student Design Competition  
成果專刊  
Portfolio

**出版機關** 教育部  
**發行人** 潘文忠  
**地址** 10051 臺北市中山南路 5 號  
**電話** 886-2-77366051  
**主辦機關** 教育部青年發展署  
**執行單位** 2017 臺灣國際學生創意設計大賽執行小組 /  
亞洲大學視覺傳達設計學系  
**贊助單位** 財團法人看見台灣基金會、財團法人溫世仁文教基金會  
**專輯主編** 林磐聳  
**專輯副主編** 游明龍、廖偉民、李新富、張天捷、林孟潔  
**專案助理** 洪誼新、黃維萱、楊安琪、曾家薇、黃郁璇  
**美術編輯** 楊翊  
**攝影** 翁鈺棠  
**出版日期** 2017 年 12 月

Published by Ministry of Education

Issuer Wen-Chung Pan

Copyright Owner Ministry of Education

Address No. 5, Jhongshan S. Rd, Jongjheng District, Taipei City 10051,  
Taiwan (R.O.C)

Tel 886-2-77366051

Organizer The Youth Development Administration, MOE

Executive 2017 Taiwan International Student Design Competition Executive  
Department of Visual Communication Design, Asia University

Sponsors iSee Taiwan Foundation, Sayling Wen Cultural & Educational  
Foundation

Chief Editor Apex Lin, Pang-Soong

Vice Editor Ming-Lung Yu, Wei-Ming Liao, Shin-Fu Lee, Tien-Chieh  
Chang, Miira Lin

Project Assistant Annie Hung, Wendy Huang, Angel Yang, Clementine  
Tseng, Jenny Huang

Arts Editor Vicky Yang

Photographer Yu-Tang Weng

The Date of Publishing December 2017

ISBN 978-986-05-5017-7

GPN 1010602739

國家圖書館出版品預行編目 (CIP) 資料

臺灣國際學生創意設計大賽成果專刊 . 2017 / 林磐聳專題主編 .  
-- 臺北市 : 教育部, 2017.12

面 ; 公分

中英對照

ISBN 978-986-05-5017-7 (精裝)

1. 設計 2. 創意 3. 數位藝術 4. 作品集

960

106024692

著作財產權人：教育部



本著作係採用創用 CC 「姓名標示—非商業性—禁止改作」3.0 臺灣版授權條款授權釋出。根據本授權條款，著作權人允許使用者重製、散布、公開傳輸著作，但不得為商業目的之利用，亦不得修改本著作內容。此授權條款的詳細內容，請見中央研究院臺灣創用 CC 網站：

<http://creativecommons.org/licenses/by-nc-nd/3.0/tw/legalcode>

This work is licensed under a Creative Commons Attribution-NonCommercial-NoDerivs 3.0 Taiwan License.

「姓名標示」部分請依以下引用方式標示著作財產權人：  
亞洲大學視覺傳達設計學系（編），《2017 臺灣國際學生創意設計大賽成果專刊》，教育部發行，2017 年 12 月

本書保有所有權利。書中刊載文字、圖片皆有版權，非經本書同意，不得轉載、翻譯。

All rights reserved. No part of this publication may be copied or translated in any form by any means without permission of the publisher.